

ELKAY® SPECIFICATIONS

No Lead Two-Level Wall Mount Water Cooler Models EWTLA8K, EWTLA14K and EWTLA16K

GENERAL

Self-contained, electric refrigerated, wall hung water cooler. Capacity of 50°F drinking water based upon 80°F inlet water and 90°F ambient.

NOTE: Minimum 40 psi supply line pressure required in special circumstances where both sides of bi-level are in use simultaneously to ensure adequate stream height. Does not apply to non-refrigerated units.

NO LEAD DESIGN

THIS WATER COOLER COMPLIES WITH THE LEAD-FREE DEFINITION IN THE SAFE DRINKING WATER ACT OF 1986 AND LEAD CONTAMINATION CONTROL ACT OF 1988.

Elkay Water Coolers are manufactured with a waterway system utilizing copper components and completely lead-free material. These waterways have no lead because all lead materials, such as leaded brass, have been removed. All joints are brazed using silver solder only. No lead solder is permitted. A strainer with an easily cleanable screen is provided to allow trapping and convenient removal of water born particulate of 140 microns and larger prior to their entry into the water cooler.

CAPACITIES CHART

Model Number	Base Rate	*GPH of 50°F Drinking Water				Rated Watts	Full Load Amps	Glass† Filler Option	•Pre-Cooler	Ship. Wt. Lbs.
		Room Temperature °F								
		70°F	80°F	90°F	100°F					
EWTLA8K	7.6	9.2	8.7	8.0	7.4	370	4.0	Yes	No	108
EWTLA14K	13.5	15.5	14.6	13.5	12.4	665	7.2	Yes	No	112
EWTLA16K	15.5	17.8	16.8	15.5	14.3	510	5.5	Yes	Yes	112

*Based on 80°F inlet water temperature. •Pre-cooler capacities based on 60% spill through pre-cooler.

†Glass filler available at extra cost. Requires factory preparation to receive glass filler. Upper unit only.

Rated watts shown are based on operational (run) time, in compliance with A.R.I. Standard 1010 conditions. Specific applications will determine the actual watts consumed per hour. Watts consumed will be based on number of people served per hour (usage), ambient temperatures, and inlet water temperature.

COOLING SYSTEM

Motor Compressor: Hermetically sealed, 115 Volt, 60 Hertz single phase. Sealed-in lifetime oil supply. Equipped with electric cord and three prong molded rubber plug.

Condenser: Fan cooled, copper tube with aluminum fins. Fan motor is permanently lubricated.

Cooling Unit: Combination tube-tank type. Tube portion is continuous coil of copper tubing. Fully insulated with EPS foam which meets Underwriters Laboratories Inc. requirements for self-extinguishing plastic material.

Refrigerant Control: Refrigerant HFC-134a is controlled by accurately calibrated capillary tube for positively trouble-free performance.

Temperature Control: Enclosed adjustable thermostat is factory preset. Requires no adjustment other than for altitude requirements.

CONSTRUCTION

Fountain Top: One piece stainless steel top, polished to a uniform Elkay bright luster finish. Exclusive Cascade basin, tested most splash-resistant, features multi-level deck design with a built-in vandal-resistant strainer.

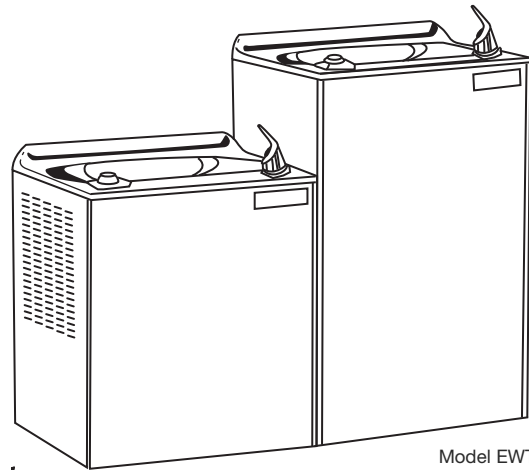

Model EWTLA8K

Exclusive Flexi-Guard® Safety Bubbler: Innovative design utilizes a pliable polyester elastomer to prevent accidental mouth injuries. Flexes on impact, then returns to original position. Strong. Abrasion-resistant. Anti-sweat. Meets UL requirements and all sanitary codes.

Removable Panel: Removable front panel offers easy accessibility to interior. Cabinet design allows for flush to wall mounting.

Color Selection: Light Gray Granite is furnished as standard unless alternate wrapper color is selected. Alternate wrapper colors in vinyl are: Sandalwood and Natural Almond. All furnished at no extra cost. Stainless Steel units available at extra cost.

Protected by Elkay's 5 Year Limited Warranty on the refrigeration system of the unit.

Elkay Pressure-Type Water Coolers are designed to operate on 20 psi to 105 psi supply line pressure. If inlet pressure is above 105 psi, a pressure regulator must be installed in the supply line. Any damage caused by reason of connecting this product to supply line pressures lower than 20 psi or higher than 105 psi is not covered by the warranty.

STANDARDS

 Elkay Electric Air Cooled Water Coolers are listed by Underwriters Laboratories Inc. and comply with both Canadian and U.S. requirements.

These units comply with A.R.I. Standard 1010.

This cooler is certified by WQA to lead-free compliance including **NSF/ANSI 61-ANNEX G, AB 1953.**

In keeping with our policy of continuing product improvement, Elkay reserves the right to change product specifications without notice. Please visit elkayusa.com for most current version of Elkay product specification sheets.

This specification describes an Elkay product with design, quality and functional benefits to the user. When making a comparison of other producers' offerings, be certain these features are not overlooked.

**No Lead Two-Level
Wall Mount Water Cooler
Models EWTLA8K, EWTLA14K and EWTLA16K**

**ELKAY®
ROUGH-IN DIMENSIONS**

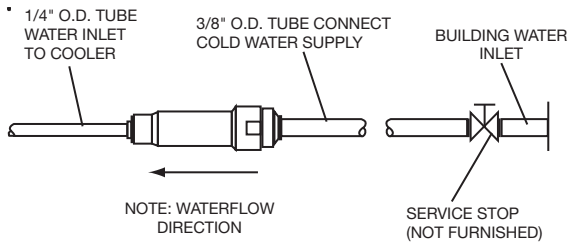

OPERATION OF QUICK CONNECT FITTINGS

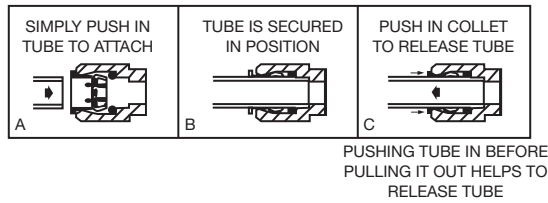

IMPORTANT!

INSTALLER PLEASE NOTE:

THIS WATER COOLER HAS BEEN DESIGNED AND BUILT TO PROVIDE WATER TO THE USER WHICH HAS NOT BEEN ALTERED BY MATERIALS IN THE COOLER WATER WAYS.

THE GROUNDING OF ELECTRICAL EQUIPMENT SUCH AS TELEPHONE, COMPUTERS, ETC. TO WATER LINES IS A COMMON PROCEDURE. THIS GROUNDING MAY BE IN THE BUILDING BUT MAY ALSO OCCUR AWAY FROM THE BUILDING. THIS GROUNDING CAN CAUSE ELECTRICAL FEEDBACK INTO A WATER COOLER CREATING AN ELECTROLYSIS WHICH CREATES A METALLIC TASTE OR CAUSES AN INCREASE IN THE METAL CONTENT OF THE WATER. THIS CONDITION IS AVOIDABLE BY INSTALLING THE COOLER USING THE PROPER MATERIALS AS SHOWN BELOW.

NOTICE

THIS WATER COOLER MUST BE CONNECTED TO THE WATER SUPPLY USING A DIELECTRIC COUPLING. THE COOLER IS FURNISHED WITH A NON-METALLIC STRAINER WHICH MEETS THIS REQUIREMENT.

THE DRAIN TRAP WHICH IS PROVIDED BY THE INSTALLER SHOULD ALSO BE PLASTIC TO COMPLETELY ISOLATE THE COOLER FROM THE BUILDING PLUMBING SYSTEM.

TOP VIEW

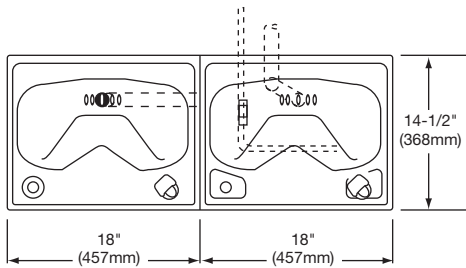

FRONT VIEW

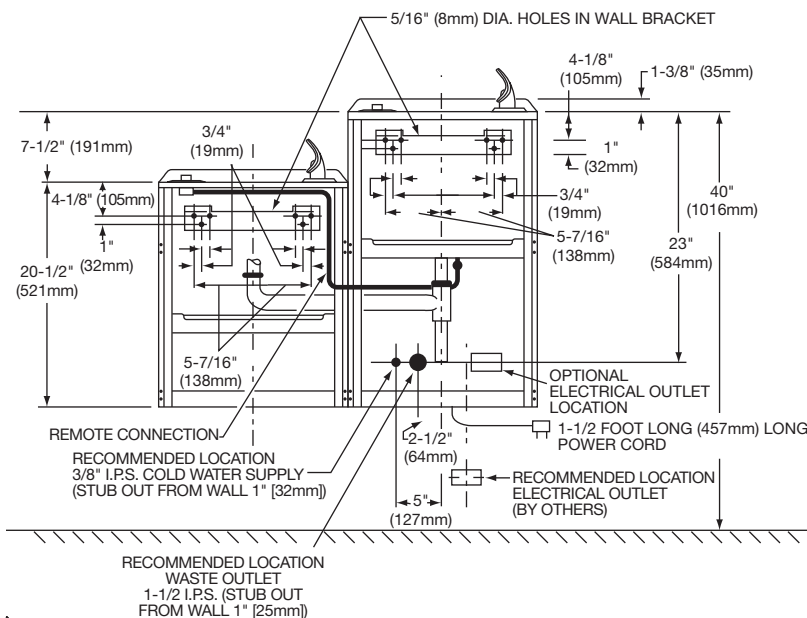

SIDE VIEW

