

# ELKAY® SPECIFICATIONS

## Two-Level Soft Sides® Water Cooler with WaterSentry® VII Filter System Barrier-Free Access Model LNTEM8RAK (Reversed)

### GENERAL

Two-level barrier-free stainless steel water cooler has recessed in-the-wall refrigeration system and stainless steel grill. All stainless steel polished to a satin finish.

Fountain has contoured basin to minimize splashing. Flexi-Guard® safety bubbler and easy to operate, fully functional, vandal-resistant front push button. Flow regulator provides constant stream from 20 to 105 psi water pressure. Vandal-resistant bottom cover plates included.

NOTE: Minimum 40 psi supply line pressure required in special circumstances where both sides of bi-level are in use simultaneously to ensure adequate stream height. Use of water filtered unit in this situation is not recommended.

Energy efficient refrigeration system utilizes a combination tank continuous-tube type evaporator, refrigerant drier, and capillary tube.

**THIS WATER COOLER COMPLIES WITH THE REQUIREMENTS OF A.D.A. (AMERICANS WITH DISABILITIES ACT) WHEN PROPERLY INSTALLED. UNIT IS COMPLIANT IF INSTALLED IN AN ALCOVE AND IS ALSO COMPLIANT WHEN MOUNTED ON AN EXPOSED WALL IF A WING WALL IS LOCATED ON THE RIGHT SIDE OR IF A 97258C APRON IS INSTALLED UNDER THE UPPER UNIT.**

### NO LEAD DESIGN

**THIS WATER COOLER COMPLIES WITH THE LEAD-FREE DEFINITION IN THE SAFE DRINKING WATER ACT OF 1986 AND LEAD CONTAMINATION CONTROL ACT OF 1988.**

Elkay Water Coolers are manufactured with a waterway system utilizing copper components and completely lead-free material. These waterways have no lead because all lead materials, such as leaded brass, have been removed. All joints are brazed using silver solder only. No lead solder is permitted.

### WATERSENTRY® FILTER SYSTEM

Elkay Water Coolers are equipped with the WaterSentry VII Filter System. Tested to NSF/ANSI Standard 53 yields a reduction of soluble and in-soluble lead content to less than 0.015mg/l. This translates to lead reduction levels of 93% to 99%. Class 1 particulate reduction as tested per NSF/ANSI 42. Removes over 97.5% of free available chlorine which provides Class 1 performance as tested to NSF/ANSI 42. Provides taste and odor improvement.

### CAPACITIES CHART

Model Number	Base Rate	*GPH of 50°F Drinking Water			Rated Watts	Full Load Amps	Glass† Filler Option	Pre-Cooler	Ship. Wt. Lbs.
		Room Temperature °F							
		70°F	80°F	90°F					
LNTEM8RAK	7.5	9.1	8.3	7.5	370	4.0	Yes	No	140

\*\*Based on 80°F inlet water temperature

†Glass filler available at extra cost. Requires factory preparation to receive glass filler. Long fountain only. Order Model LNTEM8FRAK. Glass filler LK1110 or LK1114 sold separately.

Rated watts shown are based on operational (run) time, in compliance with A.R.I. Standard 1010 conditions. Specific applications will determine the actual watts consumed per hour. Watts consumed will be based on number of people served per hour (usage), ambient temperatures, and inlet water temperature.

### COOLING SYSTEM

**Motor Compressor:** Hermetically sealed, reciprocating type, 115V, 60 Hz single phase. Sealed in lifetime oil supply.

**Condenser:** Fan cooled, copper tube with aluminum fins. Fan motor is permanently lubricated.

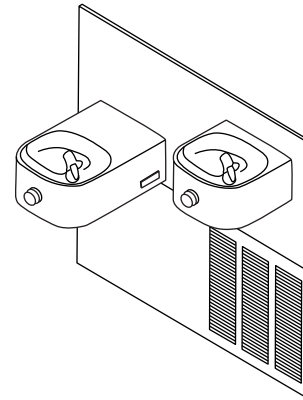

Model LNTEM8RAK

**Cooling Unit:** Combination tube-tank type. Self cleansing. Tube portion is continuous coil of copper tubing. Tank is stainless steel. Fully insulated with EPS foam which meets Underwriters Laboratories Inc. requirements for self extinguishing material.

**Temperature Control:** Enclosed adjustable thermostat is factory preset. Requires no adjustment other than for altitude requirements.

**Refrigerant Control:** Refrigerant HFC-134a is controlled by accurately calibrated capillary tube for positively trouble-free performance.

### CONSTRUCTION

**Fountain Body:** #18 gauge, type 304 nickel bearing stainless steel polished to a lustrous satin finish with high shined outer edge. Contoured basin offers large strike area to minimize splashing. Fully functional stainless steel push bars are easy to operate and have raised letters to aid visually impaired.

**Exclusive Flexi-Guard® Safety Bubbler:** Innovative design utilizes an infused anti-microbial pliable polyester elastomer to prevent accidental mouth injuries. Flexes on impact, then returns to original position. Strong. Abrasion-resistant. Anti-sweat. Keyed in location to prevent rotation.

**Front Panel Grill:** Made of type 304 stainless steel, polished to a uniform Elkay satin finish. Removable louvered ventilating grill encloses refrigeration unit and plumbing.

**Wall Mounting Frame:** MF200 frame furnished with each unit. Frame allows flush mounting to finished wall.

**Drain:** LK464 drain and trap assembly included.

**Protected by Elkay's 5 Year Limited Warranty** on the refrigeration system of the unit.

Elkay Pressure-Type Water Coolers are designed to operate on 20 psi to 105 psi supply line pressure. If inlet pressure is above 105 psi, a pressure regulator must be installed in the supply line. Any damage caused by reason of connecting this product to supply line pressures lower than 20 psi or higher than 105 psi is not covered by the warranty.

### STANDARDS

 Elkay Electric Air Cooled Water Coolers are listed by Underwriters Laboratories Inc. and comply with both Canadian and U.S. requirements.

These units comply with A.R.I. Standard 1010.

This cooler is certified by WQA to lead-free compliance including NSF/ANSI 61-ANNEX G, AB 1953.

In keeping with our policy of continuing product improvement, Elkay reserves the right to change product specifications without notice. Please visit [elkayusa.com](http://elkayusa.com) for most current version of Elkay product specification sheets.

This specification describes an Elkay product with design, quality and functional benefits to the user. When making a comparison of other producers' offerings, be certain these features are not overlooked.

Elkay

[elkayusa.com](http://elkayusa.com)

2222 Camden Court  
Oak Brook, IL 60523

Printed in U.S.A.  
©2011 Elkay

(Rev. 4/11) 8-23D

**Two-Level Soft Sides® Water Cooler  
with WaterSentry® VII Filter System  
Barrier-Free Access  
Model LNTEM8RAK (Reversed)**

**ELKAY®**  
**ROUGH-IN DIMENSIONS**

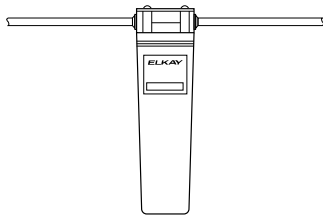

WaterSentry® VII Filter System

**OPERATION OF QUICK CONNECT FITTINGS**

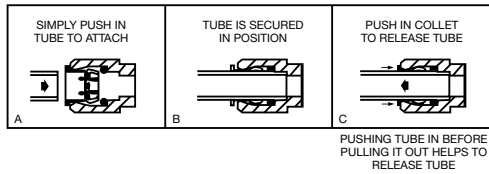

**FIG. 1**

**IMPORTANT!  
INSTALLER PLEASE NOTE:**

The grounding of electrical equipment such as telephone, computers, etc., to water lines is a common procedure. This grounding may be in the building or may occur away from the building. This grounding can cause electrical feedback into a water cooler, creating an electrolysis which causes a metallic taste or an increase in the metal content of the water. This condition is avoidable by using the proper materials as indicated below.

To minimize electrically induced corrosion, all water coolers should be connected to the water supply using an electrically isolating coupling. This cooler is furnished with non-metallic filter which meets this requirement.

The drain fittings which are provided by the installer should also be plastic to electrically isolate the cooler from the building plumbing system.

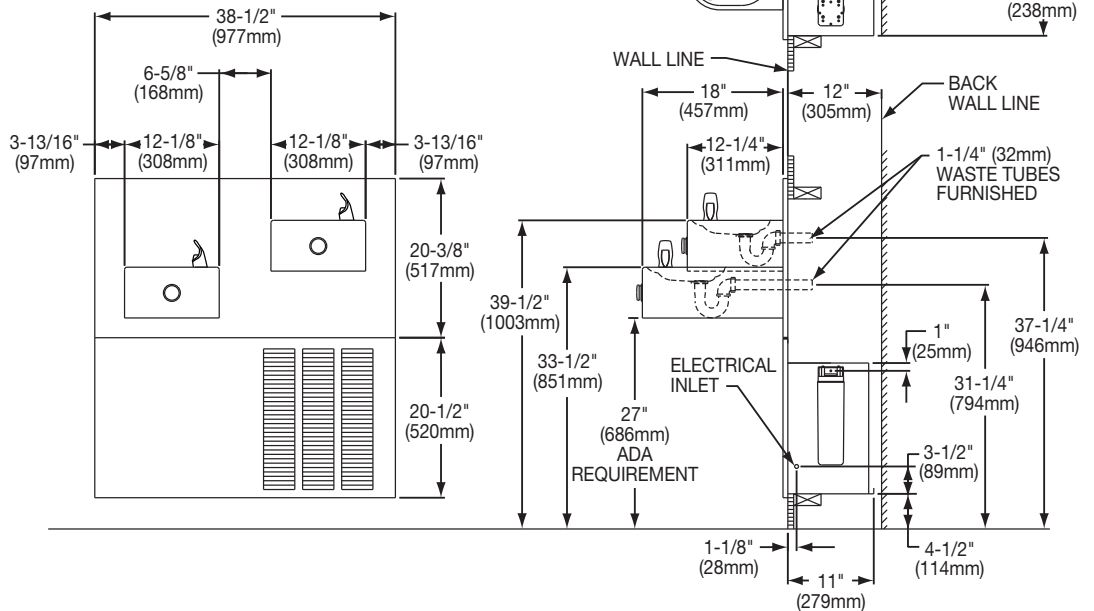

**LNTEM8RAK MOUNTING FRAME INSTRUCTIONS**

**1. Cut a square rectangular wall opening 37-1/2" (953mm) W x 37-3/4" (959mm) H and 4-1/2" (114mm) above the floor line.** These dimensions are required to obtain proper rim and bubbler heights for compliance with ANSI standard A117.1. (See Figure 2)

**2. Reinforce the wall opening on all sides so that it will adequately support the water fountain.** This reinforcement must support up to 150 lbs static load and provide a means for securing the frame assembly in place.

**NOTE:** Building construction must allow for adequate air flow on both sides and top of remote chiller unit. Minimum of 4" (102mm) is required. (See Figures 1 & 2)

**3. Install plumbing and electrical rough-ins.** See Figure 1 for location of the supply water inlet to chiller and for the location of the waste water outlet. A junction box for a (3) wire, 10 amp branch circuit is provided on the inside of the chiller. (Standard 120 Volts, 60 Hz and single phase) See Figure 2 for the electrical inlet location.

**4. Remove frame assembly and related hardware from packaging.** Attach the two frames together thru the upright supports with (4) 5/16" x 3/4" (19mm) long bolts and nuts (provided). Tighten securely.

**NOTE:** Frame with higher upper channel to be on the right side.

**5. Install the frame assembly squarely in wall opening with frame upright support edges flush with the finished wall face.** Secure the frame to the wall thru holes with (12) 5/16" x 2" (51mm) long lag bolts or screws (not provided). Tighten securely.

**NOTE:** Be sure that frame is squared in location. Do not use less than required screw quantity and size.

**6. Attach the chiller shelf support rods to the right side frame uprights at the second set of holes counting from the bottom and to the shelf at the (2) side holes.** Line up the other shelf holes with the frame bottom holes and fasten the assembly to the wall using appropriately sized wood screws or bolts and nuts (provided). (See Figure 2)

**FIG. 2**

