

## FEATURES & BENEFITS

### SHOWERHEAD

AXION<sup>®</sup> MSR stainless steel showerhead uses a hydrodynamic design to give equal distribution of water throughout the entire footprint of flow.

### VALVE

Valve is designed so the full flow of water remains on with the simple tug of the triangular pull rod. Unit also comes equipped with a stainless steel ball and stem to provide added protection against corrosion and breakage.

### PULL ROD

Barrier-free designed unit comes equipped with 56" (142.2 cm) long pull rod to accommodate wheel chair access.

### QUALITY CONTROL

Valve assembly is pre-built for reduced installation time and an added peace of mind for the installer.

### SAFETY

8" x 10-3/4" (20.3 x 27.3 cm) universal emergency sign make the unit easily detected in an emergency. Test card to record weekly checks helps maintain the unit's best working quality.



## OPTIONS

- Scald Protect Bleed Valve: Model SP157A, stainless steel scald protection bleed valve. Automatic thermal actuator bleed valve opens when internal water temperature reaches 98° F (36.7° C) and closes at 95° F (35° C).
- Thermostatic Mixing Valve: Model 9201E AXION<sup>®</sup> Emergency Tempering Valve thermostatically mixes hot and cold water to provide a safe fluid supply for emergency showers and eyewash equipment, with a flow rate of 31 gpm (117.3 L).
- Thermostatic Mixing Valve: Model 9201H Lead-free AXION<sup>®</sup> Emergency Tempering Valve thermostatically mixes hot and cold water to provide a safe fluid supply for emergency showers and eyewash equipment, with a flow rate of 31 gpm (117.3 L).
- Emergency Alarm System: Model 9001, 1-1/4" 120 VAC emergency alarm and light system. Buzzer and flashing light are activated by an 1-1/4" double pole, double throw flow switch.

For more information, visit [www.hawsco.com](http://www.hawsco.com) or call (888) 640-4297.

## SPECIFICATIONS

Model 8163 wheelchair accessible ceiling mounted drench shower shall include the AXION<sup>®</sup> MSR hydrodynamic design polished stainless steel showerhead with 20 gpm flow control, brass stay-open ball valve equipped with a stainless steel ball and stem, 56" (142.2 cm) stainless steel pull rod with triangular handle, universal sign, and 1" NPT supply.

## APPLICATIONS

Where the body of any person may be exposed to injurious or corrosive materials, suitable facilities for quick drenching or cleansing of the body shall be provided within the work area for immediate emergency use. Emergency eyewash facilities and deluge showers shall be in unobstructed and accessible locations that require no more than 10 seconds for the injured person to reach. Model 8163 is certified by CSA to meet the ANSI Z358.1 Standard for Emergency Eyewash and Shower Equipment.



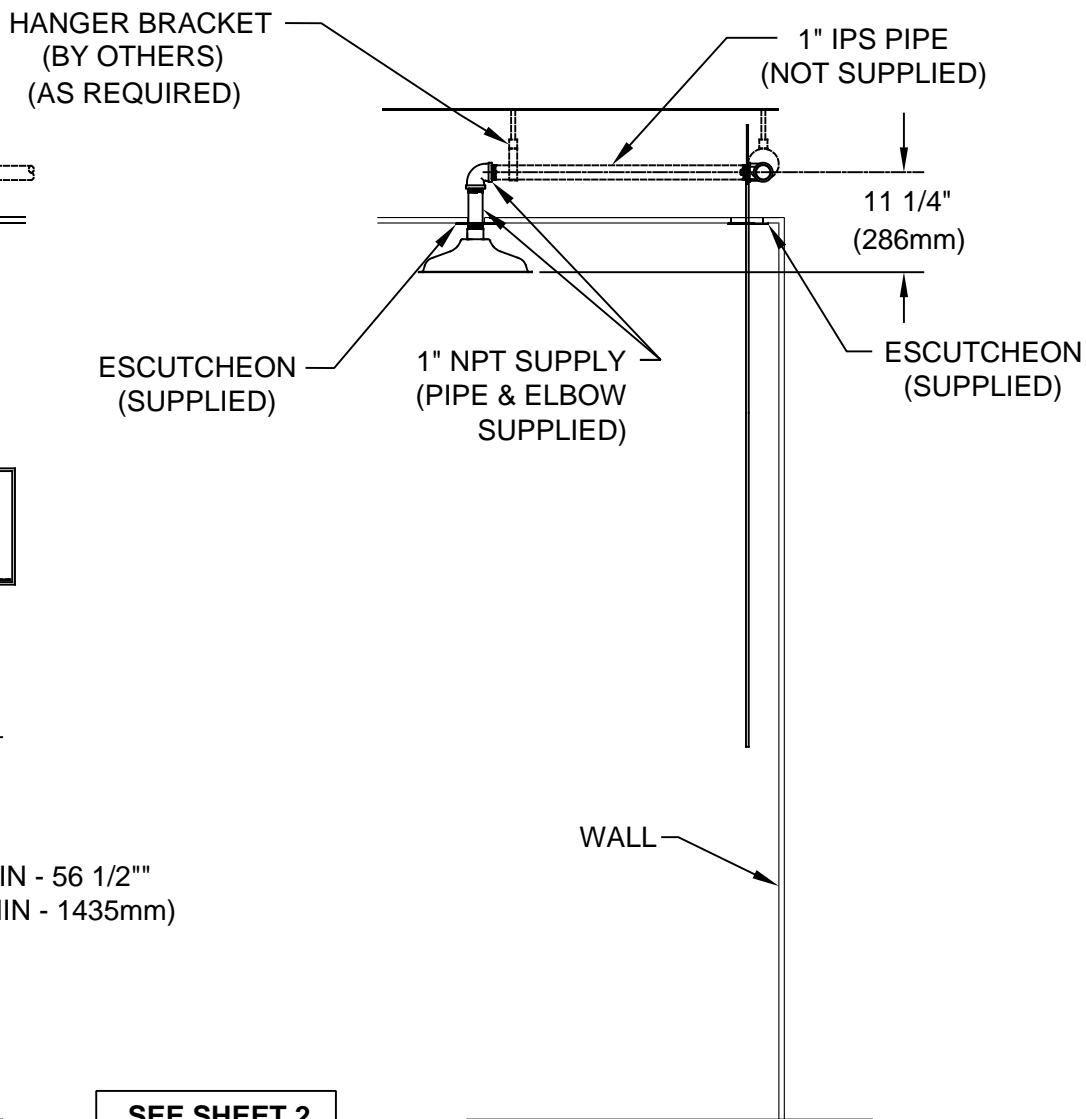
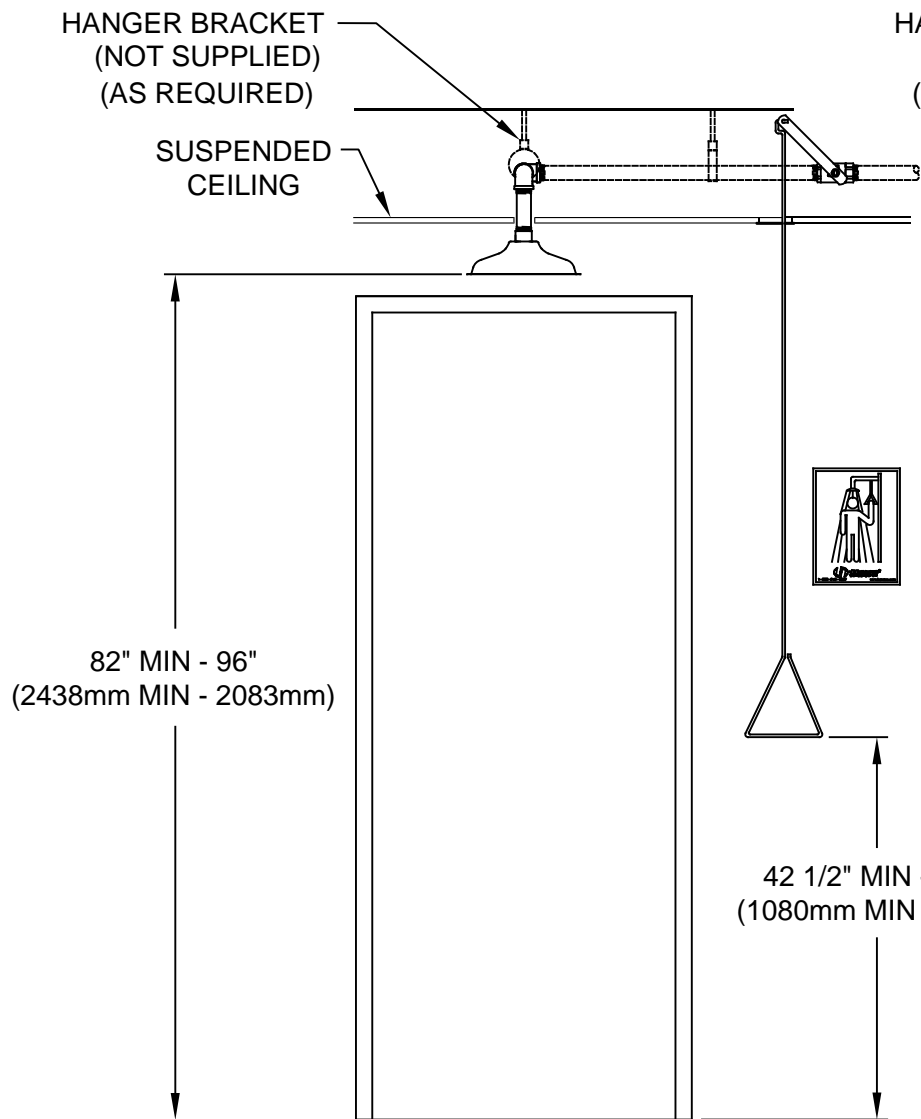

**SEE SHEET 2 FOR TOP VIEW**

NOTES:

1. WHEN INSTALLING THIS UNIT, LOCAL, STATE, OR FEDERAL CODES SHOULD BE ADHERED TO FOR INSTALLATION DIMENSIONS (LOCATIONS), WASTE AND SUPPLY REQUIREMENTS OTHER THAN SHOWN.
2. TO COMPLY WITH ANSI Z358.1-2014 FOR EMERGENCY SHOWER EQUIPMENT:
  - SHOWER SHALL BE POSITIONED SUCH THAT SHOWER HEAD IS NO LESS THAN 82" (2083mm) AND NO GREATER THAN 96" (2438mm) FROM SURFACE ON WHICH USER STANDS.
  - SHOWER SPRAY PATTERN SHALL HAVE A MINIMUM DIAMETER OF 20" (508mm) AT 60" (1524mm) ABOVE SURFACE ON WHICH USER STANDS, AND CENTER OF SPRAY PATTERN SHALL BE LOCATED NO LESS THAN 16" (406mm) FROM NEAREST OBSTRUCTION.
3. DIMENSIONS MAY VARY BY ±1/2" (13 mm).

		<b>Haws</b> <sup>®</sup>		1455 KLEPPE LANE		SPARKS, NEVADA 89431 (775) 359-4712 FAX (775) 359-7424 E-MAIL: HAWS@HAWS.CO.COM WEBSITE: WWW.HAWS.CO.COM
				ECN NO. REVISED PER BY: MODEL(S) ECN: 5279 VWC		
DRAWN: DO	DATE: 5/98	CHKD.: VWC	8163 SHOWER		PART NUMBER: 0002080137.D	
APPROVED: FV	DATE: 02/16/18	SCALE: NA	DRAWING TYPE: INSTALLATION	SIZE: A	REVISION: 8 SHEET 1 OF 2	

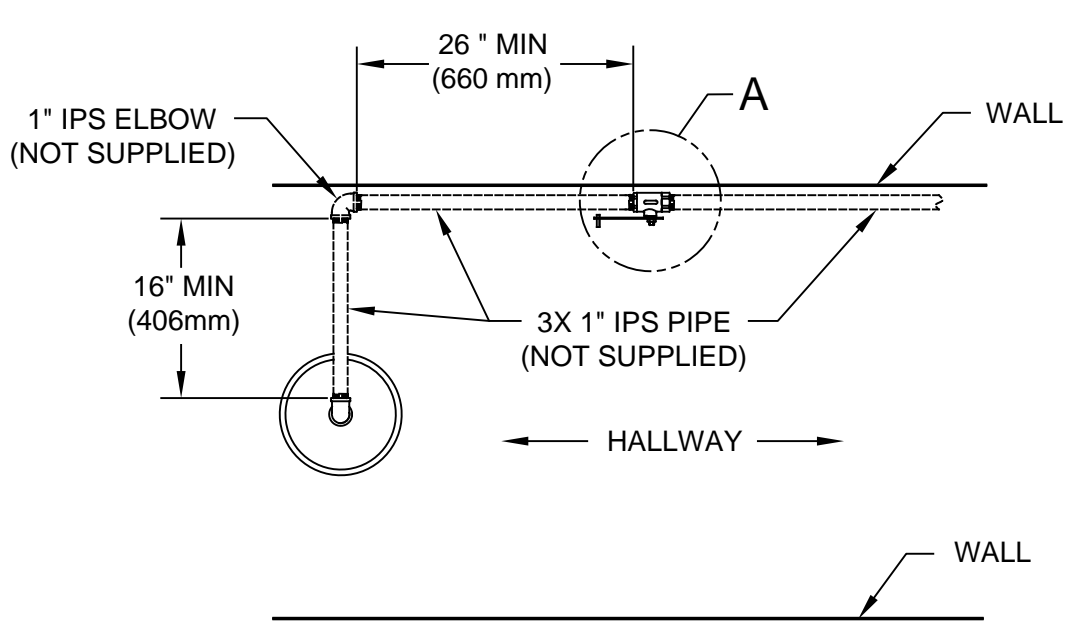

TOP VIEW

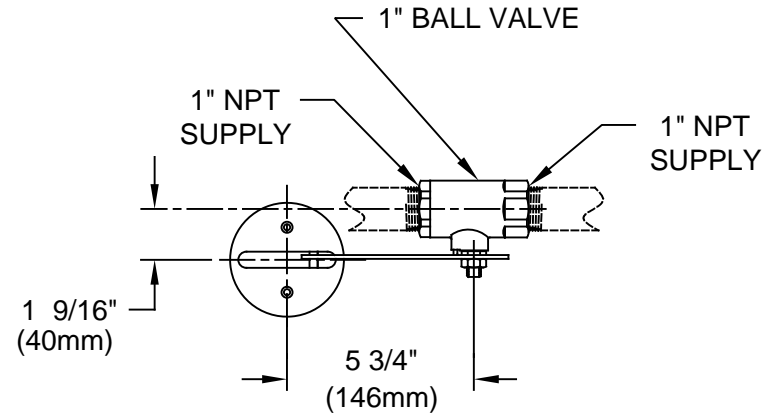

DETAIL A  
(ESCUTCHEON)

		<b>Haws</b> <sup>®</sup>		1455 KLEPPE LANE SPARKS, NEVADA 89431 (775) 359-4712 FAX (775) 359-7424 E-MAIL: HAWS@HAWSCO.COM WEBSITE: WWW.HAWSCO.COM	
				MODEL(S) 8163 SHOWER	
ECN NO. ECN: 5279	REVISED PER DATE: 5/98	BY: VWC	CHKD.: VWC	DRAWN: DO	APPROVED: FV
DATE: 02/16/18		SCALE: NA	DRAWING TYPE: INSTALLATION	SIZE: A	SHEET 2 OF 2