



model **SP829SS**  
AXION® MSR Showerhead

## FEATURES & BENEFITS

### SHOWERHEAD

AXION® MSR stainless steel showerhead uses a hydrodynamic design to give equal distribution of water throughout the entire footprint of flow.

### COMFORT

The violent showerhead flows of the past have been replaced by breaking the streams of water into smaller individual droplets to provide a more comfortable shower environment.

## OPTIONS

For more information, visit [www.hawesco.com](http://www.hawesco.com) or call (888) 640-4297.



## SPECIFICATIONS

Model SP829SS AXION® MSR hydrodynamic designed stainless steel showerhead with 20 gpm (75.7 L) flow control and 1" NPT inlet.

## APPLICATIONS

Specifically, this showerhead can be used with almost any Haws shower or combination model, with the use of a 1" NPT inlet.

- NOTES:**
1. IF NECESSARY, USE DOW CORNING 832 SEALANT PLACING 5 SMALL BEADS ON THE MALE THREADS OF MATING PART (JUST ABOVE THE FIRST THREAD).

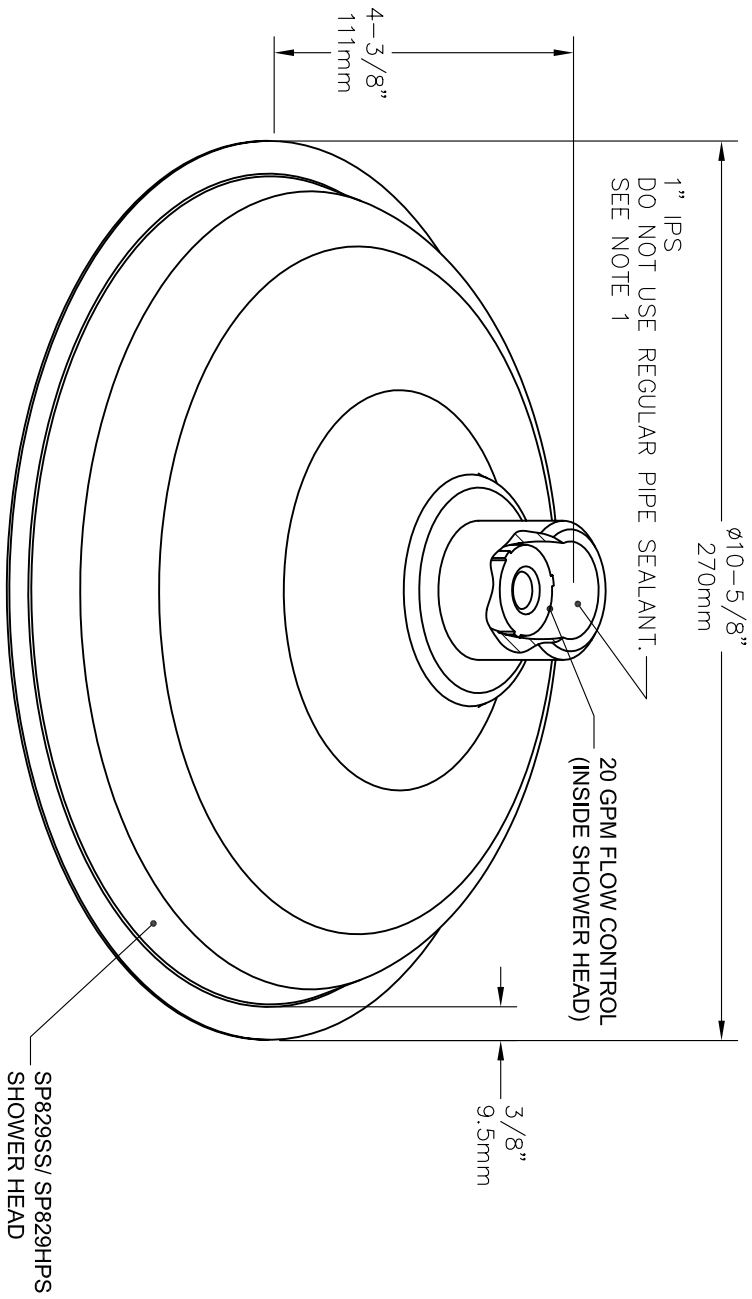

<b>Haws Corporation</b>		1455 KLEPPE LANE SPARKS, NEVADA 89431 (775) 359-4712 FAX (775) 359-7424 E-MAIL: HAWS@HAWSCCO.COM WEBSITE: WWW.HAWSCCO.COM	
FIGURE: 4358	DATE: 2/10/10	MODEL(S): SP829SS/ SP829HPS SHOWER HEAD	DATE: 02/20/10
ISSUED BY: R	DATE: 2/10/10	INFO FAX DOC #: 15971A00	DATE: 02/20/10
APPROVED BY: R	DATE: 2/10/10	INSTALLATION: EX	DATE: 02/20/10