

**PRODUCT SPECIFICATIONS**

Elkay Soft Sides® Heavy Duty Bi-Level Fountain Non-Filtered, Non-Refrigerated Freeze Resistant Stainless. Features shall include Freeze Resistant, Heavy Duty Vandal Resistant. Furnished with Vandal Resistant bubbler. Mechanical Front Bubbler Button activation. Product shall be Wall Mount (On Wall), for Indoor + Outdoor applications, serving 2 station(s). Unit shall be lead-free design which is certified to NSF/ANSI 61 & 372 (lead free) and meets Federal and State low-lead requirements.

<b>Special Features:</b>	Freeze Resistant, Heavy Duty Vandal Resistant
<b>Finish:</b>	Stainless Steel
<b>Power:</b>	No Electrical Required
<b>Bubbler Style:</b>	Vandal Resistant
<b>Activation by:</b>	Mechanical Front Bubbler Button
<b>Mounting Type:</b>	Wall Mount (On Wall)
<b>Chilling Capacity:</b>	Non-refrigerated
<b>Dimensions (L x W x H):</b>	38-1/2" x 19-3/8" x 20-3/8"
<b>Approx. Shipping Weight:</b>	91 lbs.
<b>Installation Location:</b>	Indoor + Outdoor
<b>No. of Stations Served:</b>	2

\*\*When used in non-temperature controlled environments, unit(s) must be adequately winterized and/or protected from extreme heat to prevent damage where climates dictate.

**Special Note: Requires In-Wall Carrier MPW200 (sold separately)**

- Mechanically-Activated bubbler continues to supply water in event of service disruptions.
- Freeze Resistant:  
- Depending on specific installation, freeze resistant system is located either below frost line or in temperature controlled space.



**Included with Product:** Fountain, Freeze Resistant Box

**▼ Ships in multiple boxes.**

AMERICAN PRIDE. A LIFETIME TRADITION. Like your family, the Elkay family has values and traditions that endure. For almost a century, Elkay has been a family-owned and operated company, providing thousands of jobs that support our families and communities.



**PRODUCT COMPLIANCE**

- ADA & ICC A117.1
- ASME A112.19.3/CSA B45.4
- Buy American Act
- NSF/ANSI 61 & 372 (lead free)



Complies with ADA & ICC A117.1 accessibility requirements when installed according to the requirements outlined in these standards. Installation may require additional components and/or construction features to be fully compliant. Consult the local Authority Having Jurisdiction if necessary.



[Installation Instructions \(PDF\) - 98420C](#)  
[Installation Instructions \(PDF\) - 97566C](#)

Water Systems are warranted for 12 months from date of installation. **Warranty pertains to drinking water applications only. Non-drinking water applications are not covered under warranty.**

[Warranty \(PDF\)](#)

PART: \_\_\_\_\_ QTY: \_\_\_\_\_  
PROJECT: \_\_\_\_\_  
CONTACT: \_\_\_\_\_  
DATE: \_\_\_\_\_  
NOTES: \_\_\_\_\_  
APPROVAL: \_\_\_\_\_

*In keeping with our policy of continuing product improvement, Elkay reserves the right to change product specifications without notice. Please visit [elkay.com](http://elkay.com) for the most current version of Elkay product specification sheets. This specification describes an Elkay product with design, quality, and functional benefits to the user. When making a comparison of other producers' offerings, be certain these features are not overlooked.*

Optional Accessories		
<a href="#">LKAPR2</a>	Elkay Cane Apron for EHW Stainless Steel <a href="#">Spec Sheet (PDF)</a>	
<a href="#">AP99</a>	Elkay Access Panel 9" x 9" x 6" <a href="#">Spec Sheet (PDF)</a>	
<a href="#">ACCESS12X38-5</a>	Accessory - Stainless Steel Access Panel for Bi-Level Architectural Fountains <a href="#">Spec Sheet (PDF)</a>	

*In keeping with our policy of continuing product improvement, Elkay reserves the right to change product specifications without notice. Please visit [elkay.com](http://elkay.com) for the most current version of Elkay product specification sheets. This specification describes an Elkay product with design, quality, and functional benefits to the user. When making a comparison of other producers' offerings, be certain these features are not overlooked.*

**INSTALLER NOTE**

This drinking fountain is furnished with a bubbler and valve including all connecting fittings which are manufactured of completely lead free material. Shut off valve (not furnished) to accept 3/8" O.D. unplated copper tube.

**OPERATION OF QUICK CONNECT FITTINGS**

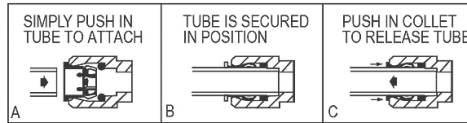

PUSHING TUBE IN BEFORE PULLING IT OUT HELPS TO RELEASE TUBE

**WHEN INSTALLING EHW217FPK WHICH INCLUDES A SURFACE MOUNTING PLATE, REFER TO THE DIAGRAMS BELOW.**

**FOR ELECTRICAL, WASTE, AND WATER SUPPLY LOCATIONS REFER TO THE INSTALLATION/OWNERS MANUAL**

**EHW217FPK WITH SURFACE MOUNTING PLATE  
MOUNTING BOLT AND ACCESS HOLE LAYOUT**

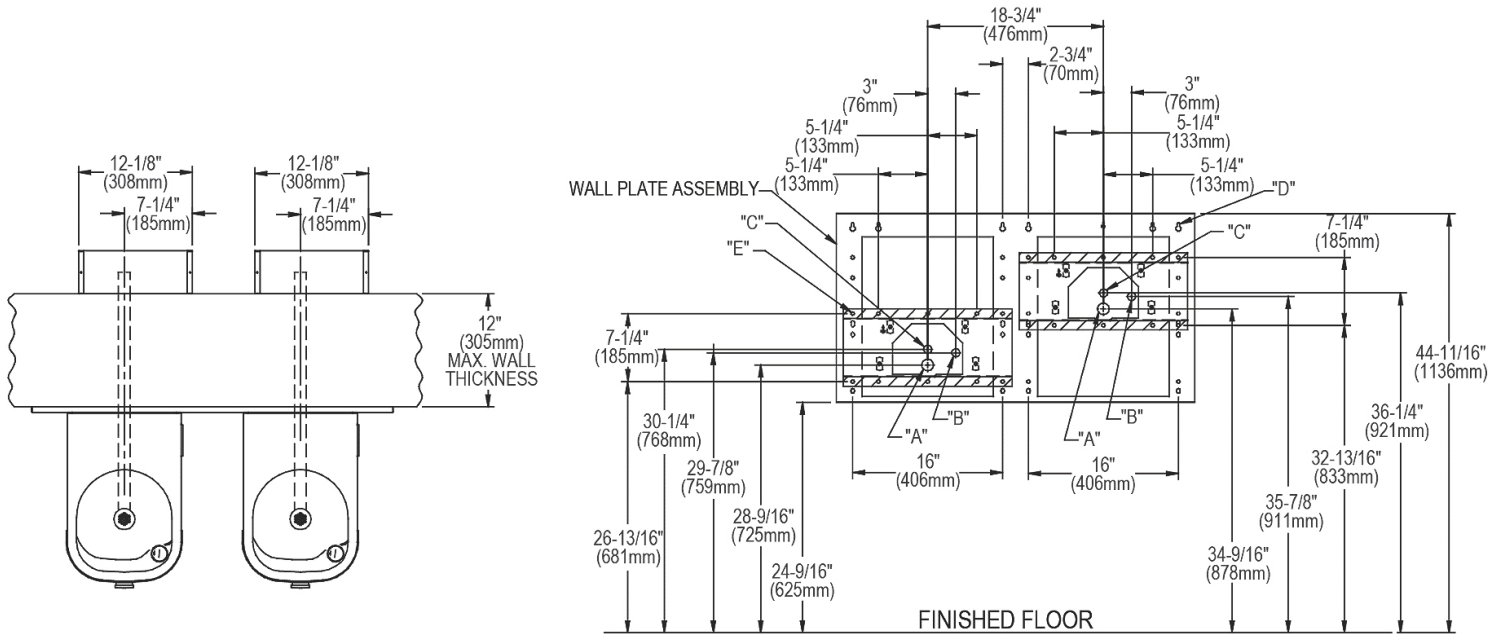

**LEGEND:**

- A = 1-3/4" DIA. (44 mm) HOLE FOR WASTE LINE
- B = 7/8" DIA. (22 mm) HOLE FOR WATER SUPPLY
- C = 7/8" DIA. (22 mm) HOLE FOR OPERATING CABLE
- D = 1/4" DIA. (6 mm) HOLE FOR MOUNTING PLATE TO WALL
- E = 3/8" DIA. (10 mm) HOLE FOR MOUNTING PLATE TO WALL

*In keeping with our policy of continuing product improvement, Elkay reserves the right to change product specifications without notice. Please visit [elkay.com](http://elkay.com) for the most current version of Elkay product specification sheets. This specification describes an Elkay product with design, quality, and functional benefits to the user. When making a comparison of other producers' offerings, be certain these features are not overlooked.*



**INSTALLER NOTE**

This drinking fountain is furnished with a bubbler and valve including all connecting fittings which are manufactured of completely lead free material. Shut off valve (not furnished) to accept 3/8" O.D. unplated copper tube.

**OPERATION OF QUICK CONNECT FITTINGS**

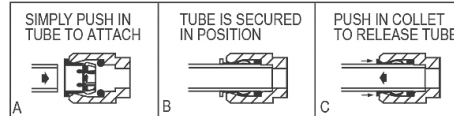

PUSHING TUBE IN BEFORE PULLING IT OUT HELPS TO RELEASE TUBE

**WHEN INSTALLING EHW217FPR WITH MPW200 IN-WALL PLATE MOUNTED DIRECTLY TO WALL STUDS, REFER TO THE DIAGRAMS BELOW. FOR ELECTRICAL, WASTE, AND WATER SUPPLY LOCATIONS REFER TO THE INSTALLATION/OWNERS MANUAL**

**EHW217FPK WITH MPW200 MOUNTING PLATE MOUNTING BOLT AND ACCESS HOLE LAYOUT**

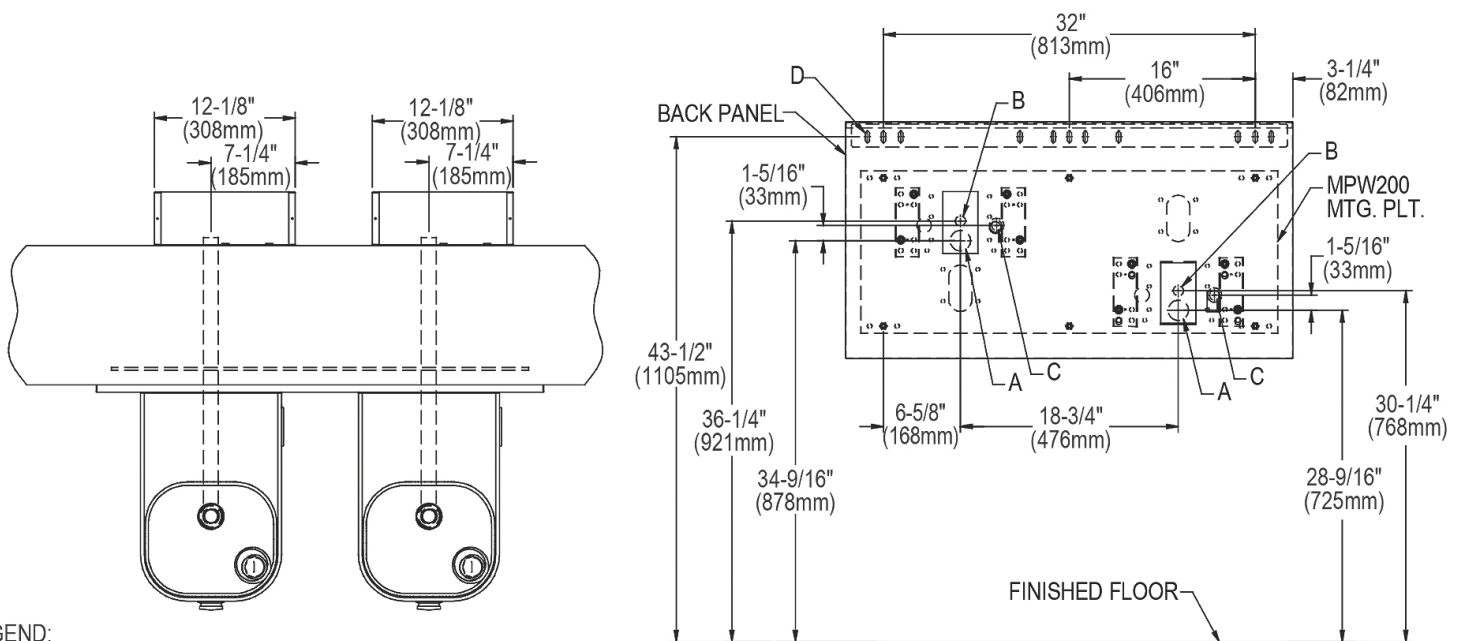

**LEGEND:**

- A = 1-3/4" Ø (44 mm) Hole for waste line
- B = 7/8" Ø (22 mm) Hole for water supply
- C = 7/8" Ø (22 mm) Hole for operating cable
- D = 1/4" Ø (6 mm) Hole for mounting plate to wall

*In keeping with our policy of continuing product improvement, Elkay reserves the right to change product specifications without notice. Please visit [elkay.com](http://elkay.com) for the most current version of Elkay product specification sheets. This specification describes an Elkay product with design, quality, and functional benefits to the user. When making a comparison of other producers' offerings, be certain these features are not overlooked.*

**EHW217FPK WITH MPW200 MOUNTING PLATE  
ROUGH-IN DRAWING**

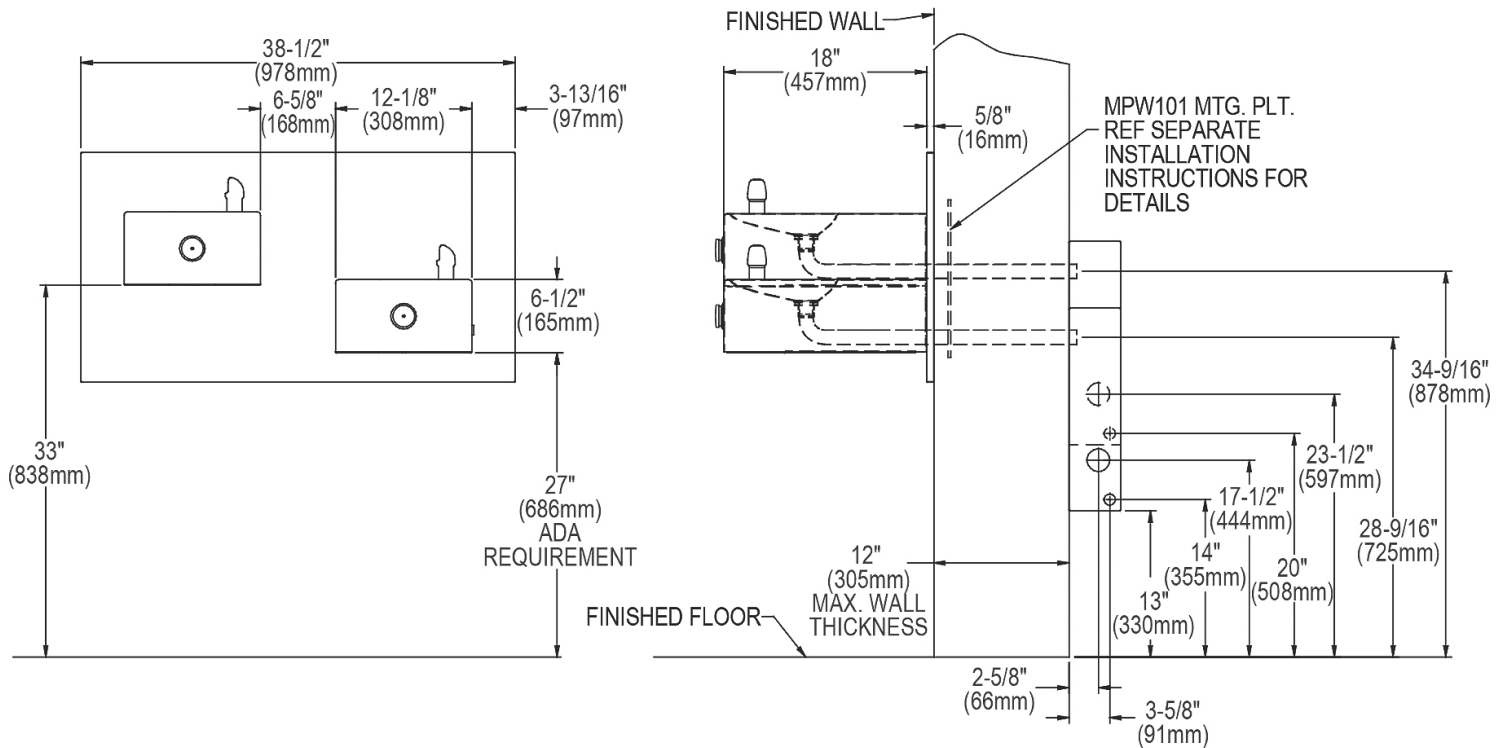

- 1. Wall should already be framed for the fountain using dimensions shown in Fig.1.** Shown dimensions pertain to installation locations. These dimensions are required for compliance with ANSI Standard A117.1 and ADA (Framing shown for reference only).
- 2. Remove bottom cover from fountain and save the screws.**
- 3. Install the fountain** using bolts and washers (provided). Tighten securely.
- 4. Attach drain tube** to fountain and cut to required length using the freeze resistant box as a guide.
- 5. Install freeze-resistant box** - see box instructions.
- 6. Replace bottom cover.**

*In keeping with our policy of continuing product improvement, Elkay reserves the right to change product specifications without notice. Please visit [elkay.com](http://elkay.com) for the most current version of Elkay product specification sheets. This specification describes an Elkay product with design, quality, and functional benefits to the user. When making a comparison of other producers' offerings, be certain these features are not overlooked.*