

**PRODUCT SPECIFICATIONS**

Elkay ezH2O® In-Wall Bottle Filling Station Non-Filtered Refrigerated Stainless. Chilling Capacity of 8.0 GPH (gallons per hour) of 50° F drinking water, based on 80° F inlet water and 90° F ambient, per ASHRAE 18 testing. Features shall include Antimicrobial\*, Green Ticker™, Hands Free, Laminar Flow, Real Drain. Electronic Bottle Filler Sensor activation. Product shall be Wall Mount (Inwall Frame/Plate), for Indoor applications, serving 1 station(s). Unit shall be certified to UL 399 and CAN/CSA C22.2 No. 120.



<b>Special Features:</b>	Antimicrobial, Green Ticker™, Hands Free, Laminar Flow, Real Drain
<b>Finish:</b>	Stainless Steel
<b>Power:</b>	115V/60Hz
<b>Bubbler Style:</b>	No Bubbler
<b>Activation by:</b>	Electronic Bottle Filler Sensor
<b>Mounting Type:</b>	Wall Mount (Inwall Frame/Plate)
<b>Chilling Capacity*:</b>	8.0 GPH
<b>Full Load Amps</b>	1
<b>Rated Watts:</b>	370
<b>Dimensions (L x W x H):</b>	19-3/4" x 3-1/2" x 40-13/16"
<b>Approx. Shipping Weight:</b>	63 lbs.
<b>Installation Location:</b>	Indoor
<b>No. of Stations Served:</b>	1
*Based on 80° F inlet water & 90° F ambient air temp for 50° F chilled drinking water.	

**Special Note: Requires mounting frame MFWS100 which is ordered seperately for early installation.**

- Green Ticker: Informs user of number of 20 oz. plastic water bottles saved from waste.
- Laminar flow provides clean fill with minimal splash.
- Key plastic components are manufactured with silver ion antimicrobial agent helping to provide clean, stain- and odor-free surfaces.
- Real Drain System eliminates standing water.

\*Antimicrobial claims are in refence to components manufactured antimicrobial agents, helping to provide clean, stain- and odor-free surfaces.

**COOLING SYSTEM**

- Compressor: Hermetically-sealed, reciprocating type, single phase. Sealed-in lifetime lubrication.
- Condenser: Fan cooled, copper tube with aluminum fins. Fan motor is permanently lubricated.
- Cooling Unit: Combination tube-tank type. Continuous copper tubing with is fully insulated with EPS foam that meets UL requirements for self-extinguishing material.
- Refrigerant Control: Refrigerant R-134a is controlled by

PART: \_\_\_\_\_ QTY: \_\_\_\_\_

PROJECT: \_\_\_\_\_

CONTACT: \_\_\_\_\_

DATE: \_\_\_\_\_

NOTES: \_\_\_\_\_

APPROVAL: \_\_\_\_\_

**Included with Product:** Bottle Filler (EZWSM8C), Chiller (ECH8)

**▼ Ships in multiple boxes.**

A Century of Tradition and Quality. For more than 100 years, Elkay has been making innovative products and providing exceptional customer care. We take pride in offering plumbing products that make life easier, inspire change and leave the world a better place.

**PRODUCT COMPLIANCE**

- ADA & ICC A117.1
- Buy American Act
- CAN/CSA C22.2 No. 120
- GreenSpec®
- NSF/ANSI 61 & 372 (lead free)
- UL 399



[Installation Instructions \(PDF\) - 1000003097](#)  
[Installation Instructions \(PDF\) - 2000000485](#)



**5 Year Limited Warranty** on the refrigeration system of the unit. Electrical components and water system are warranted for 12 months from date of installation. **Warranty pertains to drinking water applications only. Non-drinking water applications are not covered under warranty.**

[Warranty \(PDF\)](#)

*In keeping with our policy of continuing product improvement, Elkay reserves the right to change product specifications without notice. Please visit elkay.com for the most current version of Elkay product specification sheets. This specification describes an Elkay product with design, quality, and functional benefits to the user. When making a comparison of other producers' offerings, be certain these features are not overlooked.*

accurately calibrated capillary tube.

- Temperature Control: Easily accessible enclosed adjustable thermostat is factory preset. Requires no adjustment other than for altitude requirements.

Optional Accessories		
<a href="#">EWF3000</a>	Elkay Universal Filtration Kit (3000-Gallon) <a href="#">Spec Sheet (PDF)</a>	
<a href="#">MFWS100</a>	Mounting Frame for Single-station In-wall Refrigerated Bottle Filling Stations <a href="#">Spec Sheet (PDF)</a>	

*In keeping with our policy of continuing product improvement, Elkay reserves the right to change product specifications without notice. Please visit [elkay.com](http://elkay.com) for the most current version of Elkay product specification sheets. This specification describes an Elkay product with design, quality, and functional benefits to the user. When making a comparison of other producers' offerings, be certain these features are not overlooked.*

OPERATION OF QUICK CONNECT FITTINGS

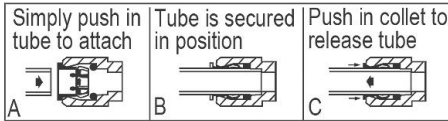

Pushing tube in before pulling it out helps to release tube

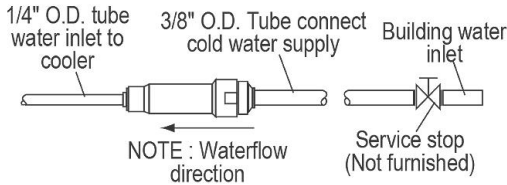

**IMPORTANT!**

**INSTALLER PLEASE NOTE :**

The grounding of electrical equipment such as telephone, computers, etc., to water lines is a common procedure. This grounding may be in the building or may occur away from the building. This grounding can cause electrical feedback into a water cooler, creating an electrolysis which causes a metallic taste or causes an increase in the metal content of the water. This condition is avoidable by using the proper materials as indicated below. To minimize electrically induced corrosion, all water coolers should be connected to the water supply using an electrically isolating coupling. This cooler is furnished with non-metallic filter which meets this requirement. The drain fittings which are provided by the installer should also be plastic to electrically isolate the cooler from the building plumbing system. These products are designed to operate on 20 psi to 105 psi supply line pressure.

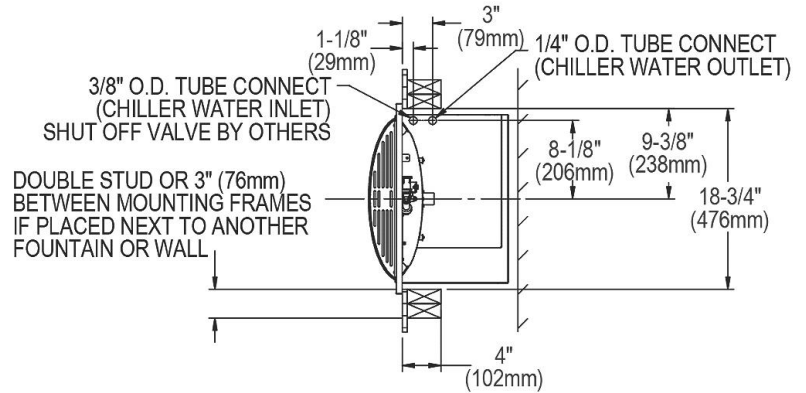

**BOTTLE FILLER SPECIFICATIONS**

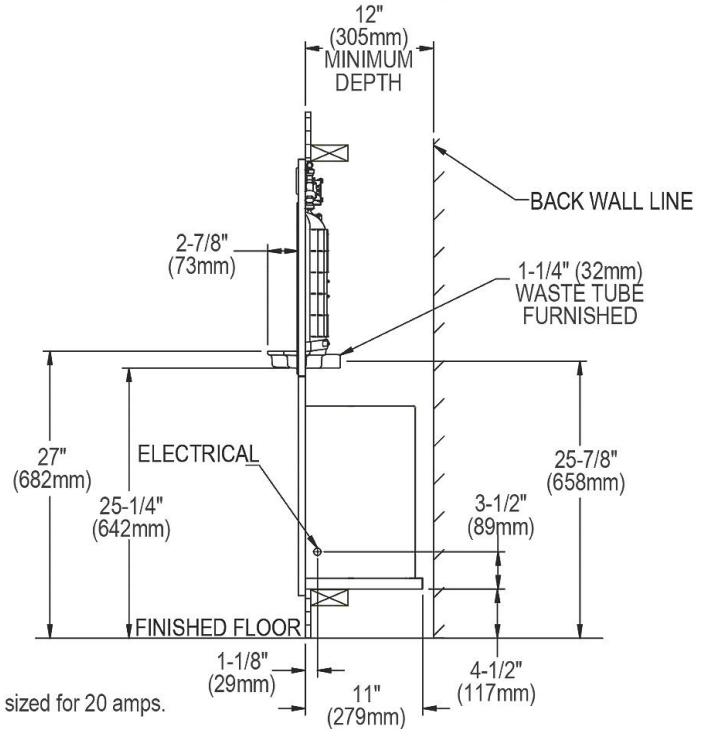
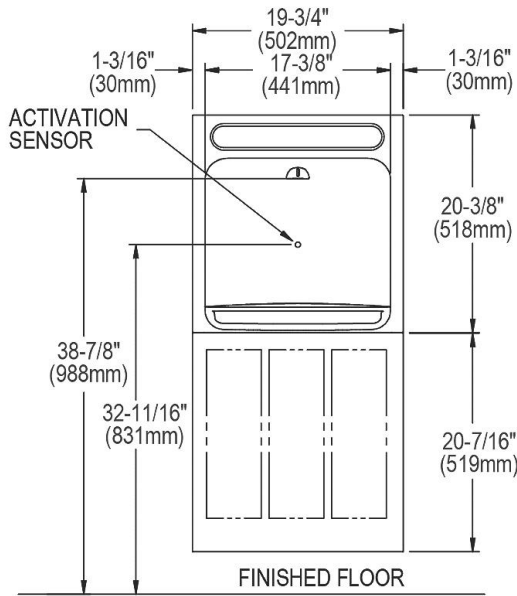

Note : New Installations Must Use Ground Fault Circuit Interrupter (GFCI). It is highly recommended that the circuit be dedicated and the load protection be sized for 20 amps.

In keeping with our policy of continuing product improvement, Elkay reserves the right to change product specifications without notice. Please visit [elkay.com](http://elkay.com) for the most current version of Elkay product specification sheets. This specification describes an Elkay product with design, quality, and functional benefits to the user. When making a comparison of other producers' offerings, be certain these features are not overlooked.