

SPECIFICATIONS

PRODUCT SPECIFICATIONS

Elkay Outdoor ezH2O® Bottle Filling Station Wall Mount with Single Fountain Non-Filtered Non-Refrigerated. Features shall include 316 Stainless, Heavy Duty Vandal Resistant, Laminar Flow. Furnished with Vandal Resistant bubbler. Mechanical Bottle Filler Button with Mechanical Front Bubbler Button activation. Product shall be Wall Mount (On Wall), for Outdoor applications, serving 2 station(s).

Special Features:	316 Stainless, Heavy Duty Vandal Resistant, Laminar Flow
Finish:	Black (BK), Blue (BLU), Evergreen (EVG), Gray (GRY), Powder Coat (12 Color Options)
Power:	No Electrical Required
Bubbler Style:	Vandal Resistant
Activation by:	Mechanical Bottle Filler Button with Mechanical Front Bubbler Button
Mounting Type:	Wall Mount (On Wall)
Chilling Capacity:	Non-refrigerated
Dimensions (L x W x H):	21-1/4" x 21-7/16" x 33-1/2"
Approx. Shipping Weight:	176 lbs.
Installation Location:	Outdoor
No. of Stations Served:	2

**When used in non-temperature controlled environments, unit(s) must be adequately winterized and/or protected from extreme heat to prevent damage where climates dictate.

Special Note: Wall Mounted Bottle Filler Station (1), Bubbler Stations (1), Choose from 12 color options

- Mechanically-Activated bubbler continues to supply water in event of service disruptions.
- Laminar flow provides clean fill with minimal splash.
- Base material constructed from marine-grade 316 stainless steel provides the ultimate corrosion protection from even the most corrosive elements.

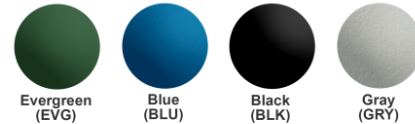

Ships in one box.

A Century of Tradition and Quality. For more than 100 years, Elkay has been making innovative products and providing exceptional customer care. We take pride in offering plumbing products that make life easier, inspire change and leave the world a better place.

PRODUCT COMPLIANCE

- ADA & ICC A117.1
- ASME A112.19.3/CSA B45.4
- Buy American Act
- GreenSpec®
- NSF/ANSI 61 & 372 (lead free)



[Installation Instructions \(PDF\) - 100004376](#)

Warranty pertains to drinking water applications only. Non-drinking water applications are not covered under warranty.

[Warranty \(PDF\)](#)

PART: _____ QTY: _____

PROJECT: _____

CONTACT: _____

DATE: _____

NOTES: _____

APPROVAL: _____

In keeping with our policy of continuing product improvement, Elkay reserves the right to change product specifications without notice. Please visit elkay.com for the most current version of Elkay product specification sheets. This specification describes an Elkay product with design, quality, and functional benefits to the user. When making a comparison of other producers' offerings, be certain these features are not overlooked.

SPECIFICATIONS

MOUNTING INSTRUCTIONS and PLUMBING CONNECTIONS

Refer to diagrams for plumbing rough-in. This fountain is to be mounted on a smooth, flat finished wall surface with adequate support.
Note: Wall mounting structure must be capable of supporting 300lb. load minimum on fountain. To secure unit, use 3/8" minimum fasteners (not provided). Water service line and waste line are to be assembled as required. Final check for leaks and correct functions of fountain should be made. (For details see the installation instructions.)

Installation requires trap to be installed in wall. A service supply stop must be installed at the fountain inlet line. Trap and service stop not included.

Caution - Fountain must be securely bolted to wall.

Note: For wall support required locations see installation instructions provided with fountain.

OPERATING PRESSURES:
Supply water 20 - 105 psi maximum

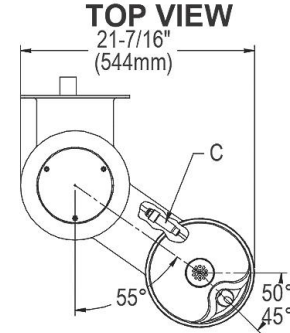

OPERATION OF QUICK CONNECT FITTINGS

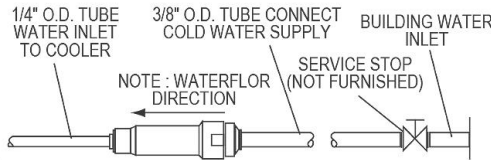
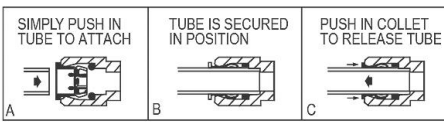

PUSHING TUBE IN BEFORE PULLING IT OUT HELPS TO RELEASE TUBE

BACK VIEW

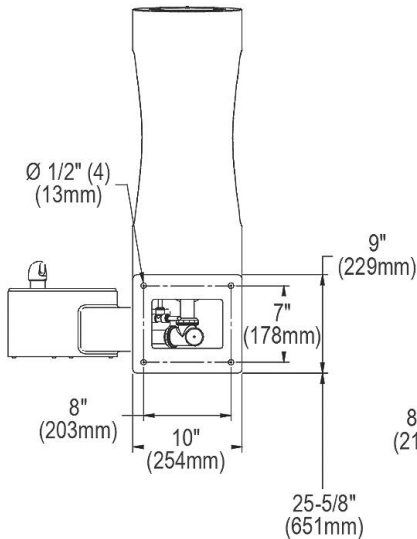

SIDE & FRONT VIEWS

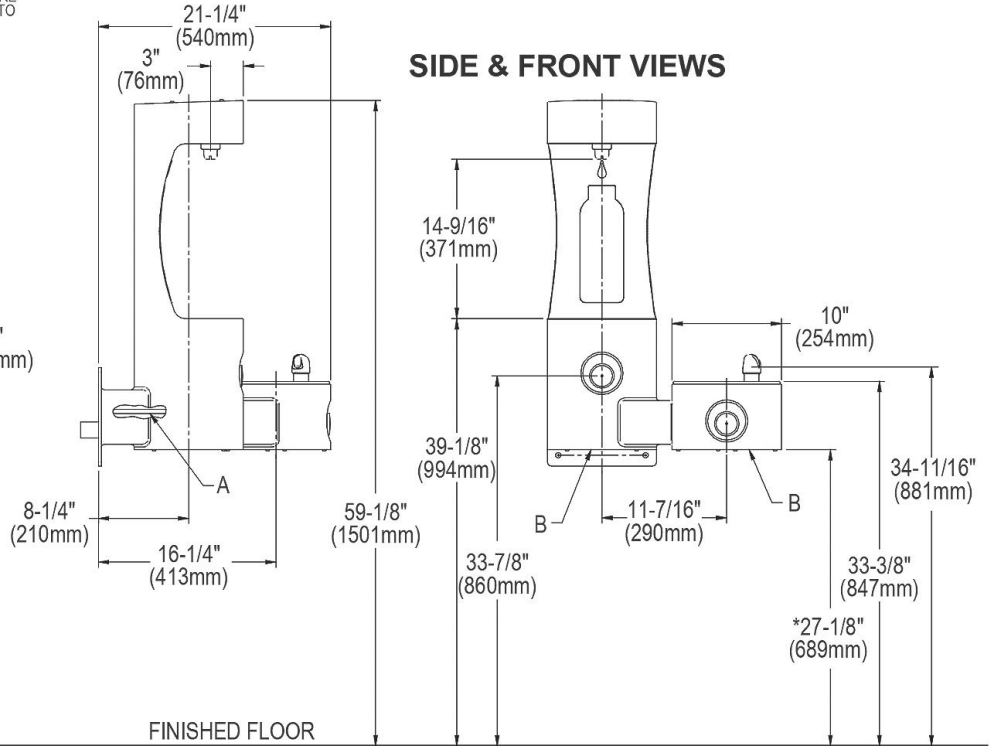

- A = 3/8" O.D. UNPLATED COPPER TUBE CONNECT - SHUT OFF VALVE BY OTHERS**
- B = REMOVABLE BOTTOM COVER**
- C = IN-LINE STRAINER**

In keeping with our policy of continuing product improvement, Elkay reserves the right to change product specifications without notice. Please visit elkay.com for the most current version of Elkay product specification sheets. This specification describes an Elkay product with design, quality, and functional benefits to the user. When making a comparison of other producers' offerings, be certain these features are not overlooked.