

**PRODUCT SPECIFICATIONS**

Elkay Outdoor Stone Fountain Pedestal Non-Filtered, Non-Refrigerated. Furnished with Vandal Resistant bubbler. Mechanical Front Bubbler Button activation. Product shall be Floor Mount/Freestanding, for Outdoor applications, serving 2 station(s). Unit shall be lead-free design which is certified to NSF/ANSI 61 & 372 (lead free) and meets Federal and State low-lead requirements.

<b>Finish:</b>	Stone Aggregate
<b>Power:</b>	No Electrical Required
<b>Bubbler Style:</b>	Vandal Resistant
<b>Activation by:</b>	Mechanical Front Bubbler Button
<b>Mounting Type:</b>	Floor Mount/Freestanding
<b>Chilling Capacity:</b>	Non-refrigerated
<b>Dimensions (L x W x H):</b>	12" x 31" x 38-1/2"
<b>Approx. Shipping Weight:</b>	225 lbs.
<b>Installation Location:</b>	Outdoor
<b>No. of Stations Served:</b>	2

\*\*When used in non-temperature controlled environments, unit(s) must be adequately winterized and/or protected from extreme heat to prevent damage where climates dictate.

- Mechanically-Activated bubbler continues to supply water in event of service disruptions.



**Included with Product:** Outdoor Fountain  
**Ships in one box.**

AMERICAN PRIDE. A LIFETIME TRADITION. Like your family, the Elkay family has values and traditions that endure. For almost a century, Elkay has been a family-owned and operated company, providing thousands of jobs that support our families and communities.



**PRODUCT COMPLIANCE**

- ADA & ICC A117.1
- ASME A112.19.3/CSA B45.4
- Buy American Act
- NSF/ANSI 61 & 372 (lead free)



Complies with ADA & ICC A117.1 accessibility requirements when installed according to the requirements outlined in these standards. Installation may require additional components and/or construction features to be fully compliant. Consult the local Authority Having Jurisdiction if necessary.

[Installation Instructions \(PDF\)](#)

**Warranty pertains to drinking water applications only. Non-drinking water applications are not covered under warranty.**

[Warranty \(PDF\)](#)

PART: \_\_\_\_\_ QTY: \_\_\_\_\_

PROJECT: \_\_\_\_\_

CONTACT: \_\_\_\_\_

DATE: \_\_\_\_\_

NOTES: \_\_\_\_\_

APPROVAL: \_\_\_\_\_

*In keeping with our policy of continuing product improvement, Elkay reserves the right to change product specifications without notice. Please visit elkay.com for the most current version of Elkay product specification sheets. This specification describes an Elkay product with design, quality, and functional benefits to the user. When making a comparison of other producers' offerings, be certain these features are not overlooked.*

**MOUNTING INSTRUCTIONS and  
PLUMBING INSTRUCTIONS**

Provide solid, well-drained surface to mount pedestal fountain (concrete pad recommended). (4) 1/2" anchor bolts (not included) should be attached firmly to mounting surface in order to secure fountain. (Refer to rough-in diagram.)

Locate and install plumbing through ground as required.  
**NOTE:** Fountain is not furnished with service valve.

Position pedestal over plumbing and secure base to anchor bolts. Remove access panels and connect supply and water lines. Turn on water supply and check for leaks. Stream height is factory set at 45-50 psi. If water pressure varies greatly from this, adjust automatic stream regulator to provide drinking stream approximately 1-1/2" above projector guard.

Reassemble access panels to pedestal.

Trap and service stop not included.

**Operating Pressures :** Supply water - 105 psi maximum.

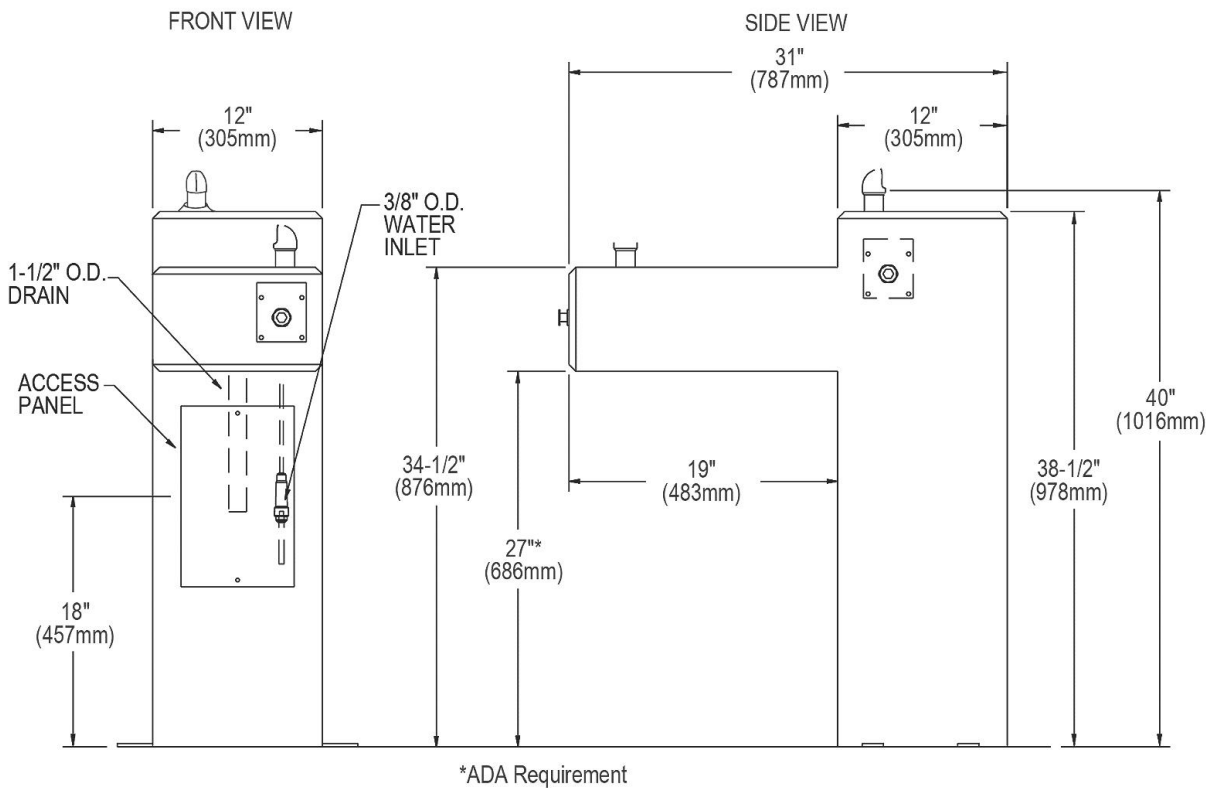
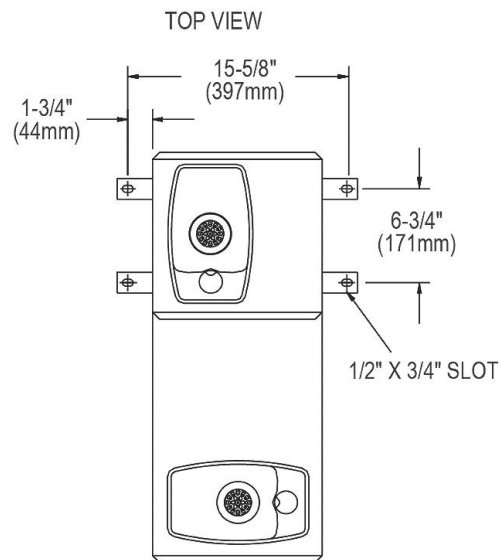

*In keeping with our policy of continuing product improvement, Elkay reserves the right to change product specifications without notice. Please visit [elkay.com](http://elkay.com) for the most current version of Elkay product specification sheets. This specification describes an Elkay product with design, quality, and functional benefits to the user. When making a comparison of other producers' offerings, be certain these features are not overlooked.*