



Haws®

model 1011HPSHO

ADA Dual Wall Mount Touchless/Push Button High Polished Fountain

FEATURES & BENEFITS

CONSTRUCTION

Rugged ADA accessible 18 gauge Type 304 high polished stainless steel swirl design bowls, 14 gauge Type 304 high polished stainless Steel brackets, and a vandal-resistant bottom plate provides a long lasting unit with added peace of mind.

HANDS FREE

Touchless operation for safety and peace of mind

BACK PANEL

Stainless steel back panel helps to protect the wall from inadvertent splashing, and its decorative satin finish increases location visibility.

MOUNTING

3/16" (.47 cm) thick steel mounting plate is larger, thicker and stronger than any other plate in the industry, and shall include the all-thread studs, nuts, and washers which allows for easy installation to a framed wall.

BUBBLER HEADS

Polished chrome-plated brass bubbler heads with integral laminar flow prevents splashing while providing a superior flow pattern. The integral 11/16" dia. basin shank and stainless anti-rotation roll pin for vandal resistance strength. Shielded, angled stream opening provides a steady source of drinking water at .45 gpm.

FOUNTAIN VALVES

Fountain incorporates a touchless sensor operated stainless steel solenoid valve controlled by a transformer on one side and a push-button activated valve which offers the only all stainless steel valve body that is machined out of solid bar stock and is fully serviceable through the front of the push button assembly offering access to the water control cartridge and integral water supply strainer on the other.



SPECIFICATIONS

Model 1011HPSHO Hi-Lo ADA wall mounted combination touchless/push button drinking fountain shall include dual 18 gauge Type 304 polished stainless steel basins with integral swirl design, 14 gauge Type 304 polished stainless steel wall brackets, 100% lead-free waterways, touchless sensor operated bubbler on one side, and push-button operated stainless steel valve with front-accessible cartridge and flow adjustment on the other, polished chrome-plated brass vandal-resistant bubbler heads with integral laminar anti-squirt flow, chrome-plated brass vandal-resistant waste strainers, vandal-resistant bottom plates, polished stainless steel back panel, high and low fountain mounting levels, and 1-1/4" O.D. (3.2 cm) waste pipes.

(P-trap and stop require rear access)

REQUIRES MODEL 6700.4 PRICED SEPARATELY.

FOR INDOOR USE ONLY

APPLICATIONS

Perfect for either public or private indoor/outdoor settings, Model 1011HPSHO is a great fit in areas where aesthetics are important to the overall appeal of the architecture. This series is precisely mounted, making it a nice addition to any surrounding. Beautiful satin finish helps to maintain the fountains overall appeal, so it always remains looking as new as it did when it was installed. Specifically, this type of wall mounted drinking fountain may be placed in settings such as: schools and other locations in and around office buildings where the temperature remains above freezing. Model meets all current Federal Regulations for the disabled including those in the Americans with Disabilities Act. Haws manufactures drinking fountains and electric water coolers to be lead-free by all known definitions including NSF/ANSI Standard 61, Section 9, NSF/ANSI 372, California Proposition 65, and the Federal Safe Drinking Water Act. Product is compliant to California Health and Safety Code 116875 (AB 1953-2006) as evaluated by CSA International.

OPTIONS

Bottle Filler: Model 1920HPSHO, bottle filler can be a standalone station, or mounted above Haws 1001HPS and 1011HPS series drinking fountain models.

Water Filter: Model 6426, 12" x 2" (30.5 x 5.1 cm), in-line lead removal element that reduces lead from incoming water supply.

Back Panel: Model BP15HPS, high polished stainless steel 15 inch back panel for Model 1920HPS.

Support Frame: Model 6800 In-wall floor mounted fixture support legs, welded steel 4-bolt floor flanges, and supplied with 'U' bolts and hardware.

For more information, visit www.hawsc.com or call (888) 640-4297.



NOTES:

1. HOLD ROUGH-IN DIMENSIONS $\pm 1/8"$ (3.2mm).
2. WHEN INSTALLING THIS UNIT, LOCAL, STATE, OR FEDERAL CODES SHOULD BE ADHERED TO FOR INSTALLATION DIMENSIONS (LOCATIONS), WASTE AND SUPPLY REQUIREMENTS OTHER THAN SHOWN.
3. INSTALLER MUST PROVIDE TRAP FOR PROPER INSTALLATION.
4. REMOVE VALVE FROM PUSH BUTTON TO INSTALL WASTE ELBOW ONTO BOWL. AFTER WASTE ELBOW IS INSTALLED, REINSTALL VALVE AND ADJUST FLOW.
5. REFER TO 5874 SERIES OPERATION AND MAINTENANCE MANUAL FOR PUSH BUTTON AND VALVE INSTALLATION/MAINTENANCE INSTRUCTIONS.
6. REFER TO 1RKH0.H & 2RKH0.H OPERATION AND MAINTENANCE INSTRUCTIONS FOR TRANSFORMER AND SENSOR SETUP.

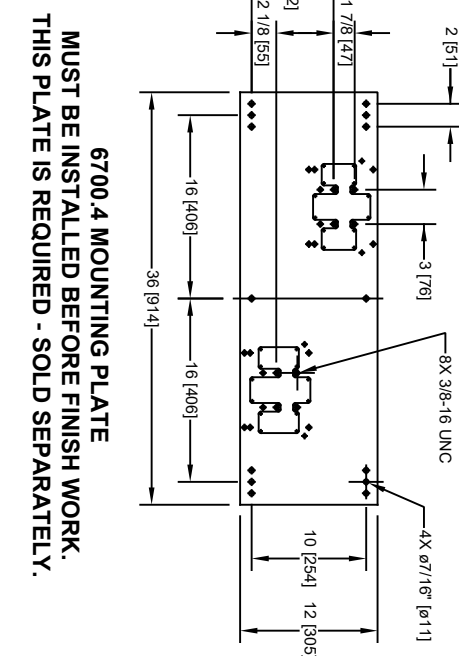
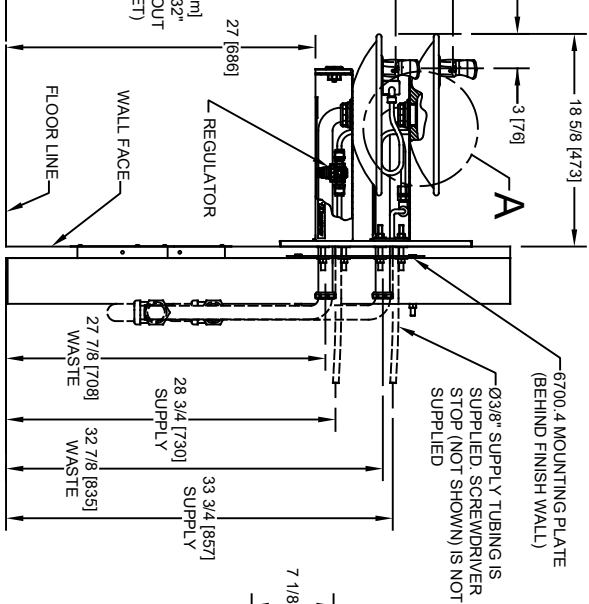
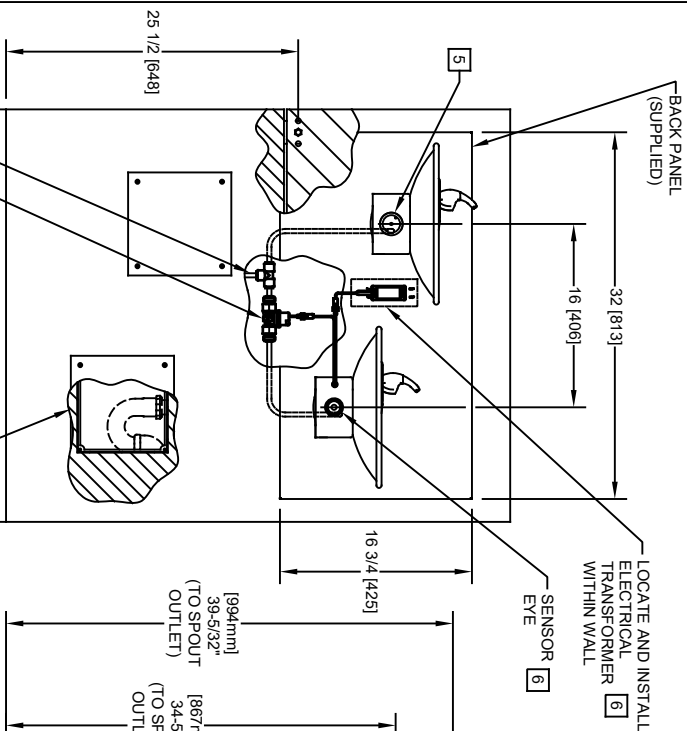
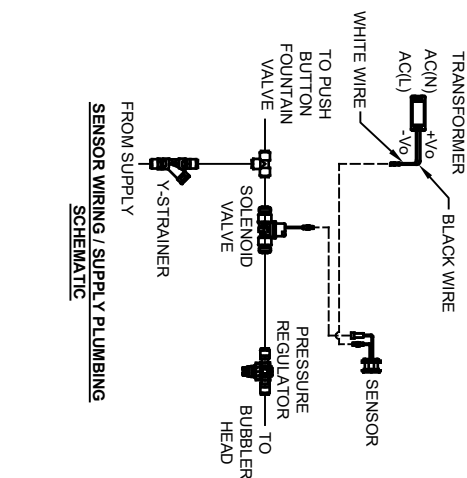
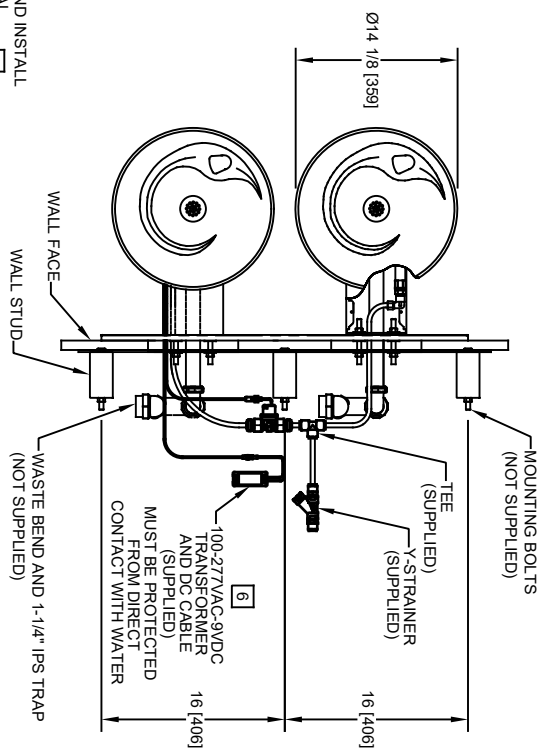

MODEL 1011HO/1011HPSHO SHOWN
 MODEL 1011HO2/1011HPSHO2 ON SHEET 2
 (ROUGH-IN DIMENSIONS APPLY TO ALL 4 MODELS)

1456 KLEPPE LANE
 SPARKS, NEVADA, 89431
 (775) 359-4712 FAX (775) 359-7424
 E-MAIL: HAWS@HAWS.CO.COM
 WEBSITE: WWW.HAWS.CO.COM

ECN NO. 5579
 ECN. 5978
 DATE: 09/15/20
 REV: 04/23/21

REVISION: 2

SCALE: 1:1

INSTALLATION: SHEET 1 OF 2

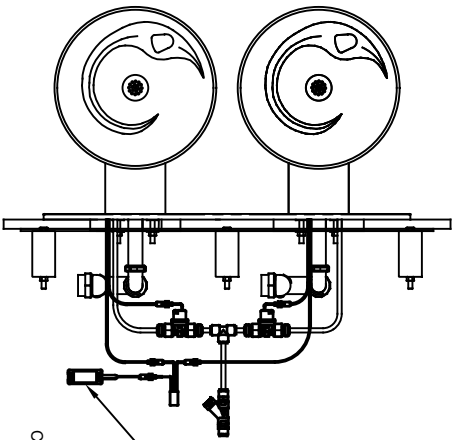

100-277VAC 9VDC TRANSFORMER AND HO CABLE (SUPPLIED) MUST BE PROTECTED FROM DIRECT CONTACT WITH WATER [6]

LOCATE AND INSTALL ELECTRICAL TRANSFORMER [6] WITHIN WALL

[6] SENSOR 7 EYE

POWER SPLITTER CABLE [6]

SENSOR [6] EYE

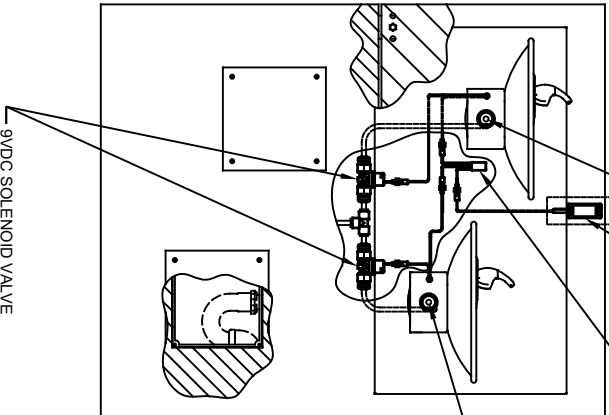

9VDC SOLENOID VALVE

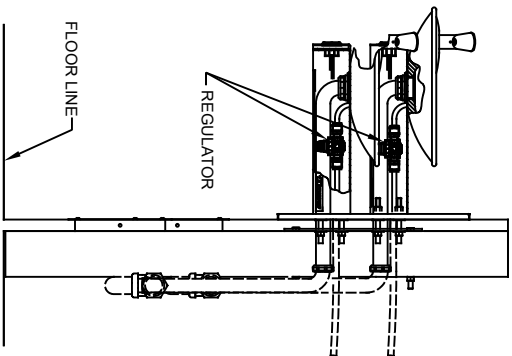

REGULATOR

FLOOR LINE

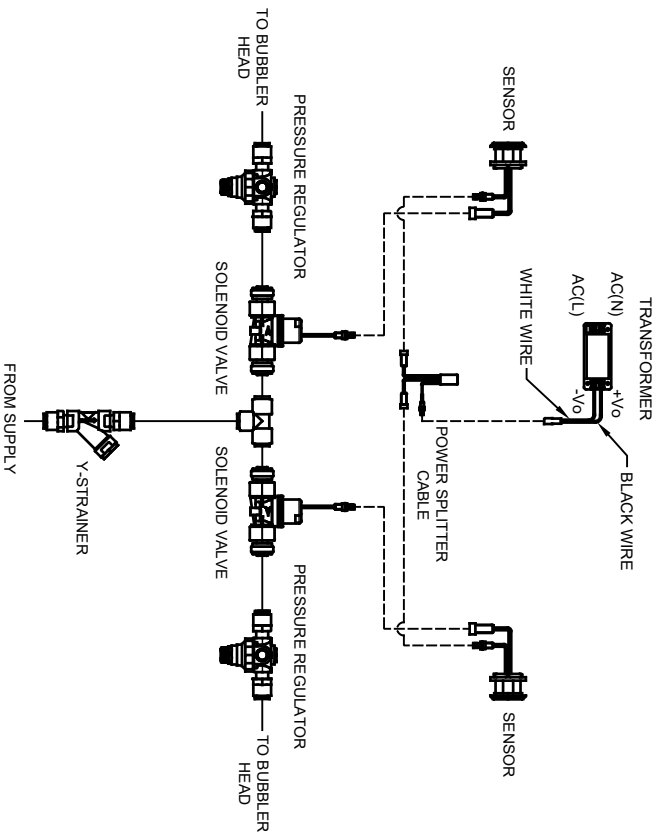

SENSOR WIRING / SUPPLY PLUMBING SCHEMATIC



Haws

1456 KLEPPE LANE
SPARKS, NEVADA, 89431
(775) 359-4712 FAX (775) 359-7424
E-MAIL: HAWS@HAWSCO.COM
WEBSITE: WWW.HAWSCO.COM

MODEL 1011HO2/1011HPSHO2 SHOWN
MODEL 1011HO/1011HPSHO ON SHEET 1
(SEE SHEET 1 FOR APPLICABLE ROUGH-IN DIMENSIONS)

ECN NO. REVISED PER BY:	MODEL(S)	PART NUMBER
5579 ECN. 5978 DP	1011HO/1011HO2/1011HPSHO/1011HPSHO2	0510001066.D
DATE: 09/15/20	CHKD:	REVISION
DATE: 04/23/21	SCALE: 1:1	2
APPROVED: BJM	DRAWING TYPE: INSTALLATION	SHEET 2 OF 2