



model 1117LNHO2

ADA Vandal-Resistant Motion-Activated Low-Profile Fountain

FEATURES & BENEFITS

INTEGRATED TRAP

All cast brass 1-1/4" NPT adjustable traps completely concealed inside bottom plates for easy installation and lack of unwanted access.

BUBBLER HEADS

Polished chrome-plated brass bubbler heads with integral 11/16" dia. basin shank and stainless anti-rotation roll pin for vandal resistance strength. Shielded, angled stream opening provides a steady, sanitary source of drinking water at .45 gpm.

FOUNTAIN VALVES

Fountain incorporates touchless sensor operated stainless steel solenoid valves controlled by a transformer for hands-free operation. A pressure regulator is used to adjust the bubbler flow according to incoming water pressures.

CUSTOM LOGO PANEL

Personalize your new or existing fountain or bottle filler where space permits with an optional customizable 10" high by 4.25" wide stainless steel panel. Virtually any company logo, event logo or graphic can be placed on this panel. Mounted with strong, moisture-resistant adhesive backing.

CONSTRUCTION

One-piece drinking fountains with low-profile design made of 14 gauge Type 304 stainless steel with 1/4" (.6 cm) thick stainless back plates welded in, and vandal-resistant stainless bottom plates. Satin finish resists stains and corrosion.

TAMPER RESISTANT

30-second obstruction time-out to reduce tampering of sensor.

VANDAL-RESISTANT

The bubbler heads, drain strainers and bottom plates are locked in place, discouraging unwanted vandalism.

OPTIONS

- Mounting Plate: Model 6700.4, in-wall mounting plate for model 1117LNHO2.
- Support Frame: Model 6800 In-wall floor mounted fixture support legs, welded steel 4-bolt floor flanges, and supplied with 'U' bolts and hardware.
- Bottle Filler Stand: Model BTL1107, add-on stainless steel stand to place bottle on when 1920 bottle filler is used.
- Bottle Filler: Model 1920HO stand-alone bottle filling station, or mounted above Haws 1001, 1011, 1107L, 1109, 1117L, and 1119 series drinking fountain models.

For more information, visit www.hawsco.com or call (888) 640-4297.



SPECIFICATIONS

Model 1117LNHO2 low profile vandal-resistant ADA wall mounted combination motion-activated/push-button drinking fountain shall include dual 14-gauge Type 304 Stainless Steel satin finish basins with integral 1/4" (.6 cm) thick stainless steel back plates, touchless sensor operated stainless steel solenoid valves with 30-second obstruction time-out controlled by a transformer, 100% lead free waterways, polished chrome-plated brass vandal-resistant bubbler heads, polished chrome-plated brass vandal-resistant waste strainers, vandal-resistant bottom plates, stainless steel satin finish back panel, and 1-1/4" NPT concealed all cast-brass traps. The patented design allows the unit to be mounted to meet ADA or Child ADA specifications.

FOR INDOOR USE ONLY

APPLICATIONS

Perfect for either public or private indoor settings, the 1117LNHO2 is a great fit in areas where aesthetics are important to the overall appeal of the architecture. Beautiful satin finish helps to maintain the fountains overall appeal. Specifically, this type of wall mounted drinking fountain may be placed in settings such as: schools and other locations in and around office buildings. Model meets all current Federal Regulations for the disabled including those in the Americans with Disabilities Act. Haws manufactures drinking fountains, faucets and electric water coolers to be lead-free by all known definitions including NSF/ANSI/CAN 61-Section 9, NSF/ANSI/CAN 372, California Proposition 65, and the Federal Safe Drinking Water Act. Product is compliant to California Health and Safety Code 116875 (AB 1953-2006), and NSF/ANSI/CAN 61: Q ≤ 1.



- NOTES:
1. HOLD ROUGH-IN DIMENSIONS $\pm \frac{1}{8}$ " (3.2MM).
 2. WHEN INSTALLING THIS UNIT, LOCAL, STATE, OR FEDERAL CODES SHOULD BE ADHERED TO. FOR INSTALLATION HEIGHTS OTHER THAN SHOWN, DIMENSIONS MARKED (*) MUST BE ADJUSTED ACCORDINGLY.
 3. REFER TO 6874 SERIES OPERATION AND MAINTENANCE MANUAL FOR PUSH BUTTON AND VALVE INSTALLATION/MAINTENANCE INSTRUCTIONS.
 4. REFER TO 1RKH0 OR 2RKH0 SERIES OPERATION INSTRUCTIONS FOR TRANSFORMER AND SENSOR SETUP.
 5. MAXIMUM ADJUSTABLE RANGE IS 15" FROM PARALLEL TO BACK WALL.

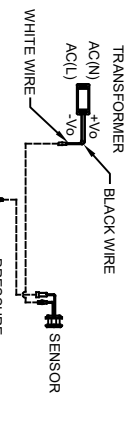

SENSOR WIRING / SUPPLY PLUMBING SCHEMATIC

3/8" O.D. SUPPLY TUBING IS SUPPLIED. SCREWDRIVER STOP (NOT SHOWN) IS NOT SUPPLIED.

3/8" O.D. SUPPLY LINE TO TEE

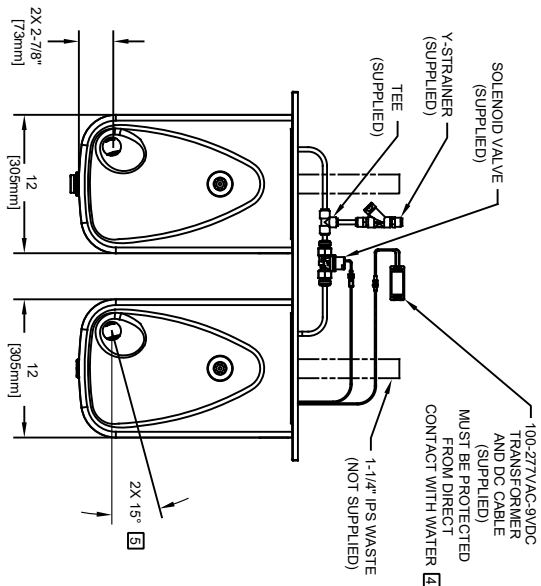

LOCATE AND INSTALL ELECTRICAL TRANSFORMER WITHIN WALL [2]

BACK PANEL (SUPPLIED)

SENSOR EYE [4]

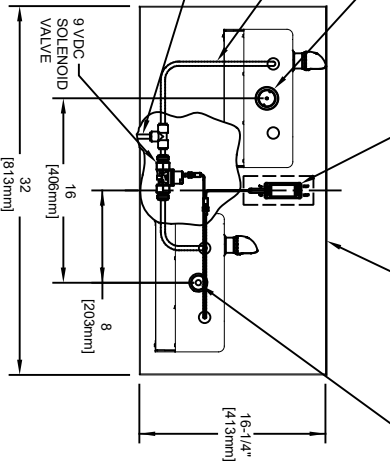

MODEL 1117LNHO SHOWN
MODEL 1117LNHO2 ON SHEET 2
(ROUGH-IN DIMENSIONS APPLY TO BOTH MODELS)

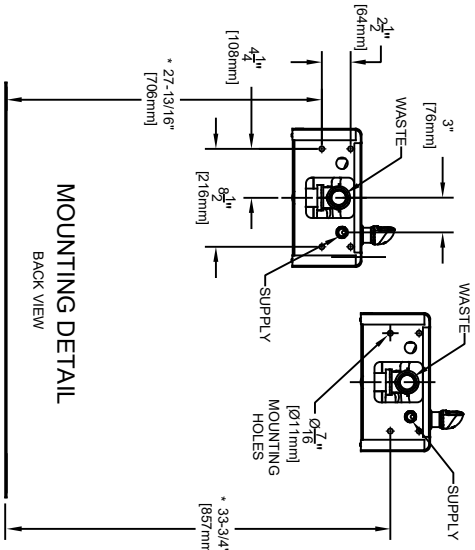

MOUNTING DETAIL

BACK VIEW

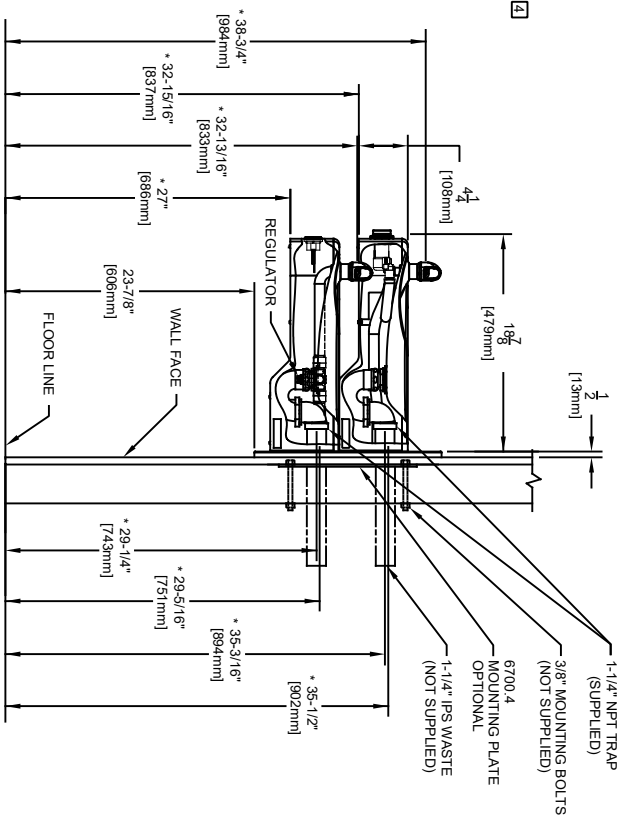

1-1/4" NPT TRAP (SUPPLIED)
3/8" MOUNTING BOLTS (NOT SUPPLIED)
6700.4 MOUNTING PLATE (OPTIONAL)
1-1/4" IPS WASTE (NOT SUPPLIED)

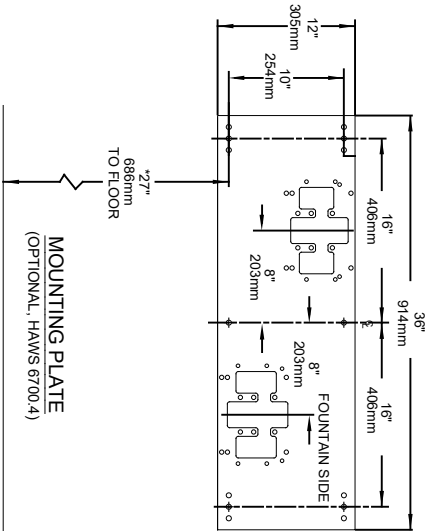

MOUNTING PLATE (OPTIONAL, HAWS 6700.4)

		MODEL(S)	
1456 KLEPPE LANE SPARKS, NEVADA 89431 (775) 359-4712 FAX (775) 359-7424 E-MAIL: HAWS@HAWS.CO.COM WEBSITE: WWW.HAWS.CO.COM		1117LNHO/1117LNHO2	
ECN NO. REVISED PER BY:	5713	DATE:	07/28/21
CHKD:	FV	DP:	
APPROVED:	DATE:	SCALE:	1:2
DRAWING TYPE:		INSTALLATION	
SHEET 1 OF 2		REVISION: 1	
PART NUMBER		0510001210.D	

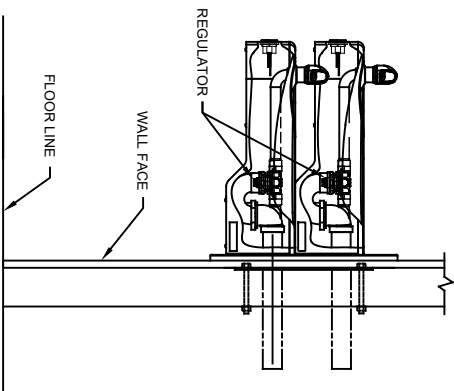
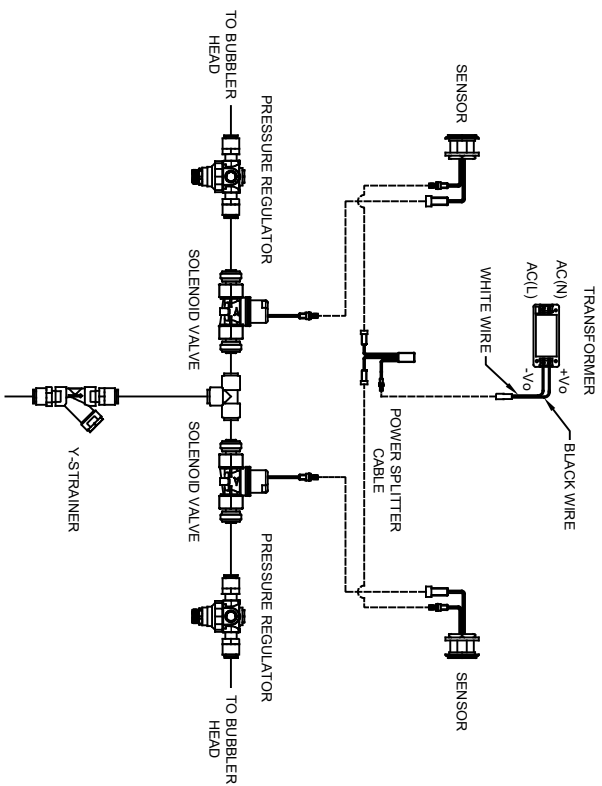
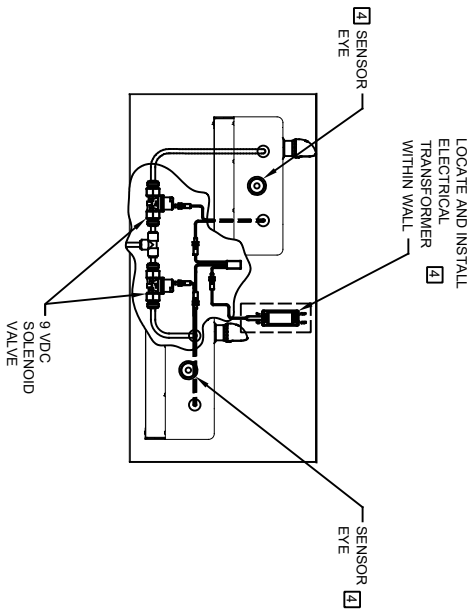
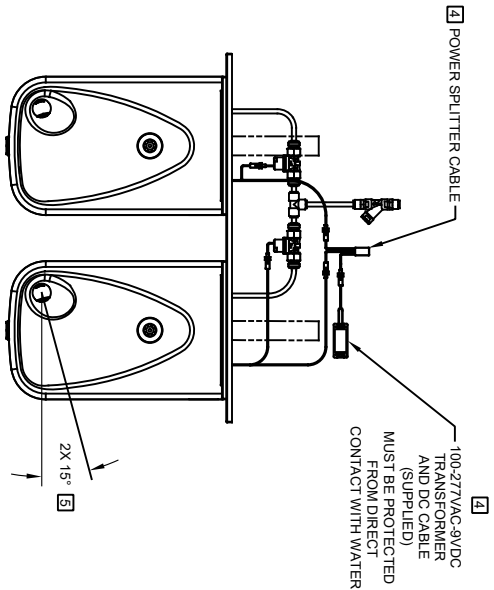

MODEL 1117NLH02 SHOWN
 MODEL 1117LNHO ON SHEET 1
 (SEE SHEET 1 FOR APPLICABLE ROUGH-IN DIMENSIONS)

		MODEL(S)	
1459 KLEPPE LANE SPARKS, NEVADA 89431 (775) 359-4712 FAX (775) 359-7424 E-MAIL: HAWS@HAWSCO.COM WEBSITE: WWW.HAWSCO.COM		1117LNHO/1117LNHO2	
ECN NO. REVISED PERBY:	5713 FV	DATE:	07/28/21
CHKD:	DP	SCALE:	1:2
APPROVED:	FV	DRAWING TYPE:	INSTALLATION
PART NUMBER		SIZE:	A
0510001210.D		SHEET:	2 OF 2
REVISION:		1	