

## FEATURES & BENEFITS

### CONSTRUCTION

Unit is made of 18 gauge Type 304 stainless steel with a satin finish that resists stains and corrosion, and has soft, rounded corners. Unit features stainless steel satin finish back panel, vandal-resistant bottom plate, and 1-1/4" integral trap.

### INTEGRATED TRAP

All cast brass 1-1/4" NPT adjustable traps completely concealed inside bottom plates for easy installation and lack of unwanted access.

### BUBBLER HEADS

Polished chrome-plated brass bubbler head with integral 11/16" dia. basin shank and stainless anti-rotation roll pin for vandal resistance strength. Shielded, angled stream opening provides a steady, sanitary source of drinking water at .45 gpm.

### DRINKING FOUNTAIN VALVES

The push-button activated valves offer the only all stainless steel valve body that is machined out of solid bar stock, is fully serviceable through the front of the push button assembly offering access to the water control cartridge and integral water supply strainer, and with front access to the water stream height adjustment for easy maintenance without having to remove the valve. Operating pressure range of 30 to 90 psi (2.1 to 6.2 bar).

### VANDAL-RESISTANT

The bubbler heads, push buttons, drain strainers and bottom plates are locked in place, discouraging unwanted vandal tampering.



## OPTIONS

- Bottle Filler: Model 1920, bottle filler can be a standalone station, or mounted above Haws 1001, 1011, 1107L, 1109, 1117L, and 1119 series drinking fountain models.
- Remote Drinking Fountain Water chiller: Model HCR8, 8 gph (30.3 L) remote water chiller provides instantaneous cooling to meet a continuous demand for chilled water.
- Support Frame: Model 6800 In-wall floor mounted fixture support legs, welded steel 4-bolt floor flanges, and supplied with 'U' bolts and hardware.
- Mounting Plate: Model 6700, in-wall mounting plate which is 36" wide by 3/16" thick solid steel that spans three studs for a heavy-duty vandal-resistant rigid installation.

For more information, visit [www.hawscos.com](http://www.hawscos.com) or call (888) 640-4297.

## SPECIFICATIONS

Model 1119 wall mounted vandal-resistant ADA drinking fountain shall include dual 18 gauge Type 304 Stainless Steel satin finish basins, vandal-resistant push-button operated stainless steel valves with front-accessible cartridge and flow adjustment, 100% lead-free waterways, polished chrome-plated brass vandal-resistant bubbler heads, polished chrome-plated brass vandal-resistant waste strainers, vandal-resistant bottom plates, stainless steel satin finish back panel, high and low fountain mounting levels, and 1-1/4" NPT traps.

## APPLICATIONS

Perfect for either public or private indoor/outdoor settings, Model 1119 is a great fit in areas where aesthetics are important to the overall appeal of the architecture. This series is precisely mounted, making it a nice addition to any surrounding. Beautiful satin finish helps to maintain the fountains overall appeal so it always remains looking as new as it did when it was installed. Specifically, this type of wall mounted drinking fountain may be placed in settings such as: schools and other locations in and around office buildings where the temperature remains above freezing. Model meets all current Federal Regulations for the disabled including those in the Americans with Disabilities Act. Haws manufactures drinking fountains, faucets and electric water coolers to be lead-free by all known definitions including NSF/ANSI/CAN 61- Section 9, NSF/ANSI/CAN 372, California Proposition 65, and the Federal Safe Drinking Water Act. Product is compliant to California Health and Safety Code 116875 (AB 1953-2006), and NSF/ANSI/CAN 61: Q ≤ 1.



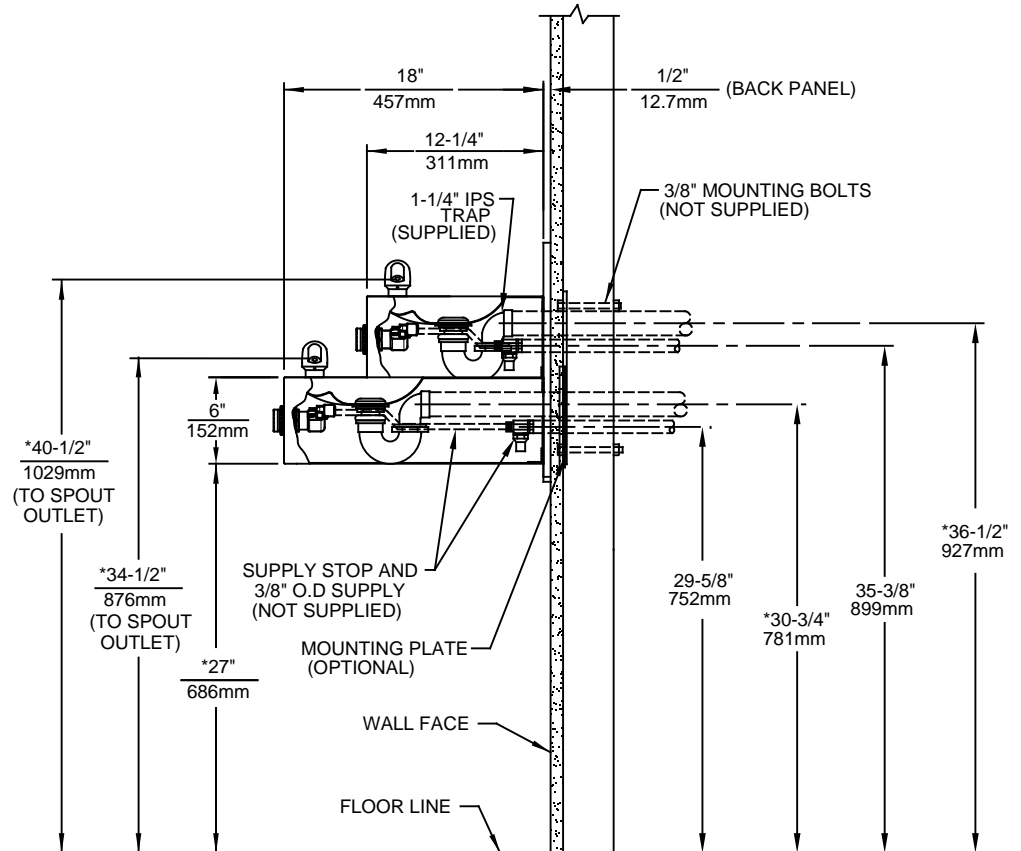
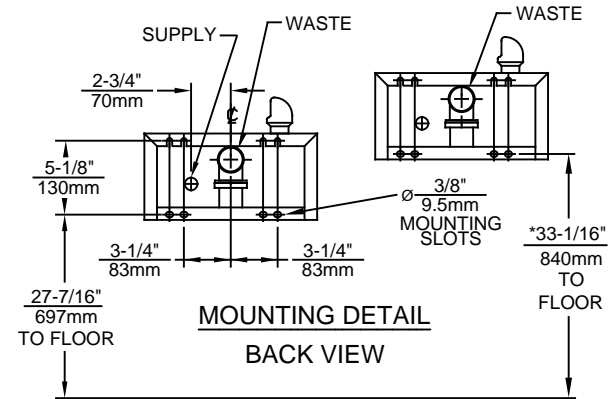
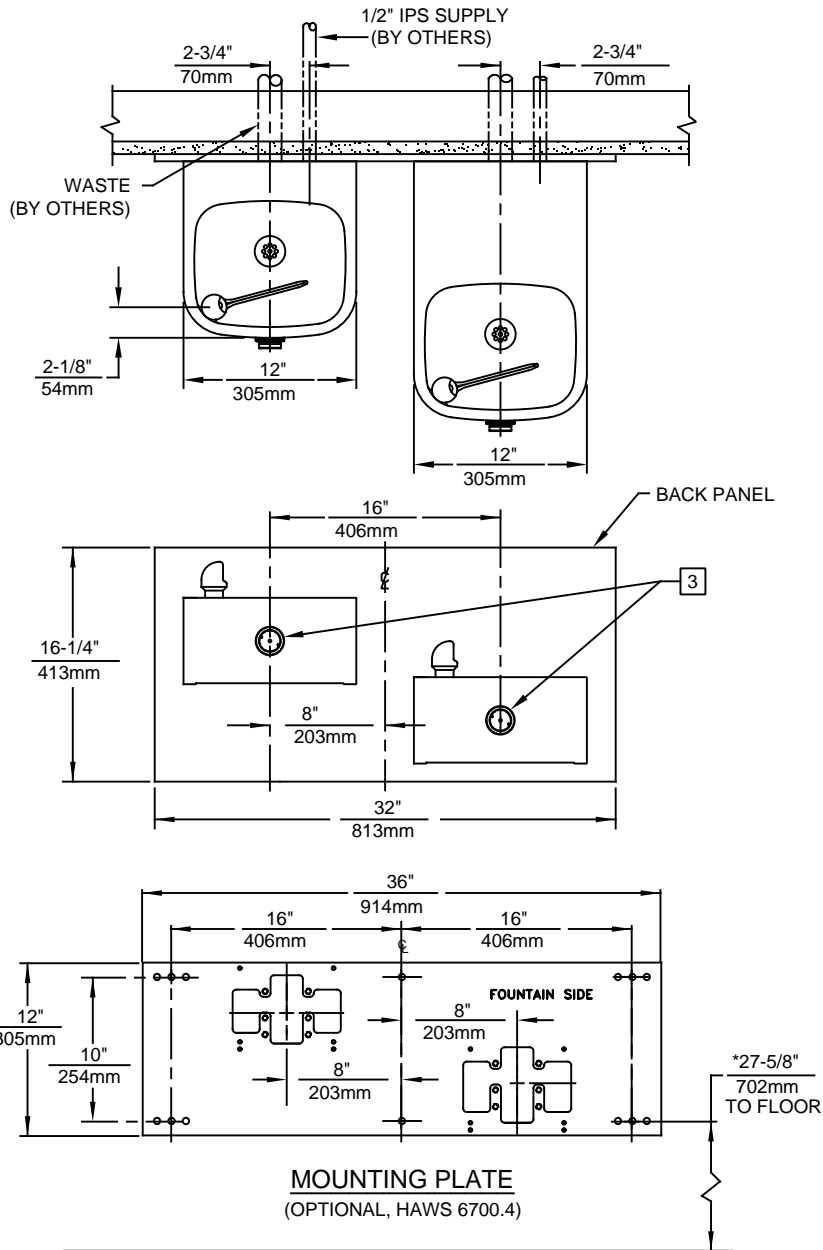

**NOTES:**

- HOLD ROUGH-IN DIMENSIONS ± 1/4" (6.4mm).
- WHEN INSTALLING THIS UNIT, LOCAL, STATE, OR FEDERAL CODES SHOULD BE ADHERED TO. FOR INSTALLATION HEIGHTS OTHER THAN SHOWN, DIMENSIONS MARKED (\*) MUST BE ADJUSTED ACCORDINGLY.
- REFER TO 5874 SERIES/VRK5874 OPERATION AND MAINTENANCE MANUAL FOR PUSH BUTTON AND VALVE INSTALLATION/MAINTENANCE INSTRUCTONS.



**Haws**

1455 KLEPPE LANE  
SPARKS, NEVADA 89431  
(775) 359-4712 FAX (775) 359-7424  
E-MAIL: HAWS@HAWSCO.COM  
WEBSITE: WWW.HAWSCO.COM

ECN NO. REVISED PER BY:	MODEL(S)	PART NUMBER
ECN: 5530 FV	1119	0002076716.D
DRAWN: F.VASQUEZ	DATE: 04/15/98	CHKD.: DP
APPROVED: NE	DATE: 03/26/20	REVISION
SCALE: 1:14	DRAWING TYPE: INSTALLATION	SIZE: A
		SHEET 1 OF 1