



model 3620

Modular Outdoor Double Bottle Filler

FEATURES & BENEFITS

BARRIER-FREE

Barrier-free capabilities combined with its ease of use allows for a number of installation location possibilities.

PUSH BUTTON VALVE

The push-button activated valve offers the 'only' all stainless steel valve body that is machined out of solid bar stock, is fully serviceable through the front of the push button assembly offering access to the water control cartridge and integral water supply strainer, and with front access to the water stream height adjustment for easy maintenance without having to remove the valve. Operating pressure range of 30 to 90 psi (2.1 to 6.2 bar).

BOTTLE FILLER

Hydration made easy with an industry leading 17" bottle area opening to allow more users access to this push button operated bottle filling station.

MODULAR CONFIGURATION

Bottle filler, drinking fountain, dog bowl and/or hose bib can be re-positioned, added or removed on site at any time. Side arm(s) can be placed high or low within its opening, and valve button position can be placed in any direction.

OPTIONS

- ❑ Drinking Fountain Bowl, ODBF: Model 3680, drinking fountain bowl assembly for the Haws 3600 series modular outdoor pedestals. Available in three standard colors - order 3680-01 silver, 3680-02 blue, and 3680-03 green.
- ❑ Pedestal Arm, ODBF: The Haws 3671 pedestal arm allows for the mounting of the Haws 3690 series bottle fillers or the 3680 series drinking fountains. Includes the model 3655 bottom access plate. Available in three standard colors - order 3671-01 silver, 3671-02 blue, and 3671-03 green.
- ❑ Modular Outdoor Bottle Filler Dog Bowl: Model 3670, dog bowl for the Haws 3600 series modular outdoor pedestals. Available in three standard colors - order 3670-01 silver, 3670-02 blue, and 3670-03 green.
- ❑ Modular Outdoor Pedestal Lockable Bib Faucet: Model 3660, compression hose bib faucet housed in a lockable compartment for the Haws 3600 series modular outdoor pedestals. Available in three standard colors - order 3660-01 silver, 3660-02 blue, and 3660-03 green.

For more information, visit www.hawsc.com or call (888) 640-4297.



STANDARD COLOR OPTIONS

Silver - 01 shown

 Blue - 02

 Green - 03

SPECIFICATIONS

Model 3620 modular outdoor, barrier-free pedestal bottle filler shall include a 3/16" phosphated-steel pedestal with silver powder-coating, two bottle filling stations, push-button operated stainless steel valves with front-accessible cartridge and flow adjustment, large-opening bottle filler with quick-fill 1 gpm flow rate, 100% lead-free waterways, polished chrome-plated vandal-resistant waste strainers, vandal-resistant access plate, integral mounting feet, and 1-1/2" slip waste.

APPLICATIONS

The 3620 offers a solution for the changing needs of outdoor settings as well as outdoor wheelchair access, appealing to all users through accessibility and safety. This outdoor bottle filler is ideal in areas such as parks, schools, and other outdoor areas where hydration facilities are needed. Model meets all current Federal Regulations for the disabled including those in the Americans with Disabilities Act, and complies with Prop 65. Certified by CSA to NSF/ANSI 61, section 9 and NSF/ANSI 372; and was evaluated to be compliant to US and Canada Plumbing Codes including Uniform Plumbing Code (UPC), International Plumbing Code (IPC) and National Plumbing Code of Canada (NPC).



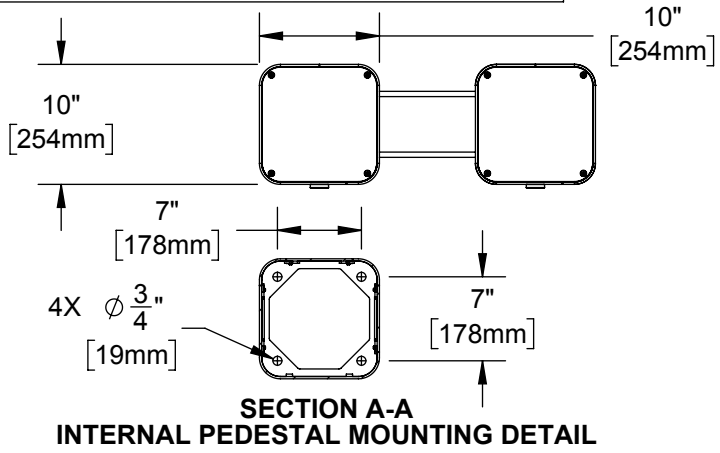

NOTE: IT IS RECOMMENDED TO REFERENCE THE LATEST ICC A117.1 ACCESSIBLE AND USABLE BUILDINGS AND FACILITIES / DEPARTMENT OF JUSTICE ADA STANDARDS FOR ACCESSIBLE DESIGN TO ENSURE COMPLIANCE.

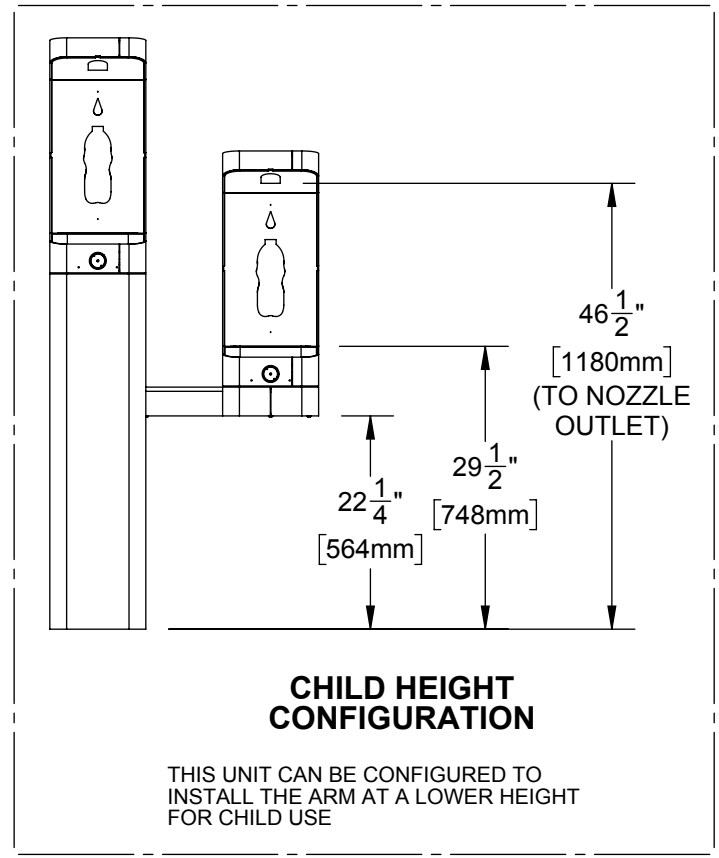
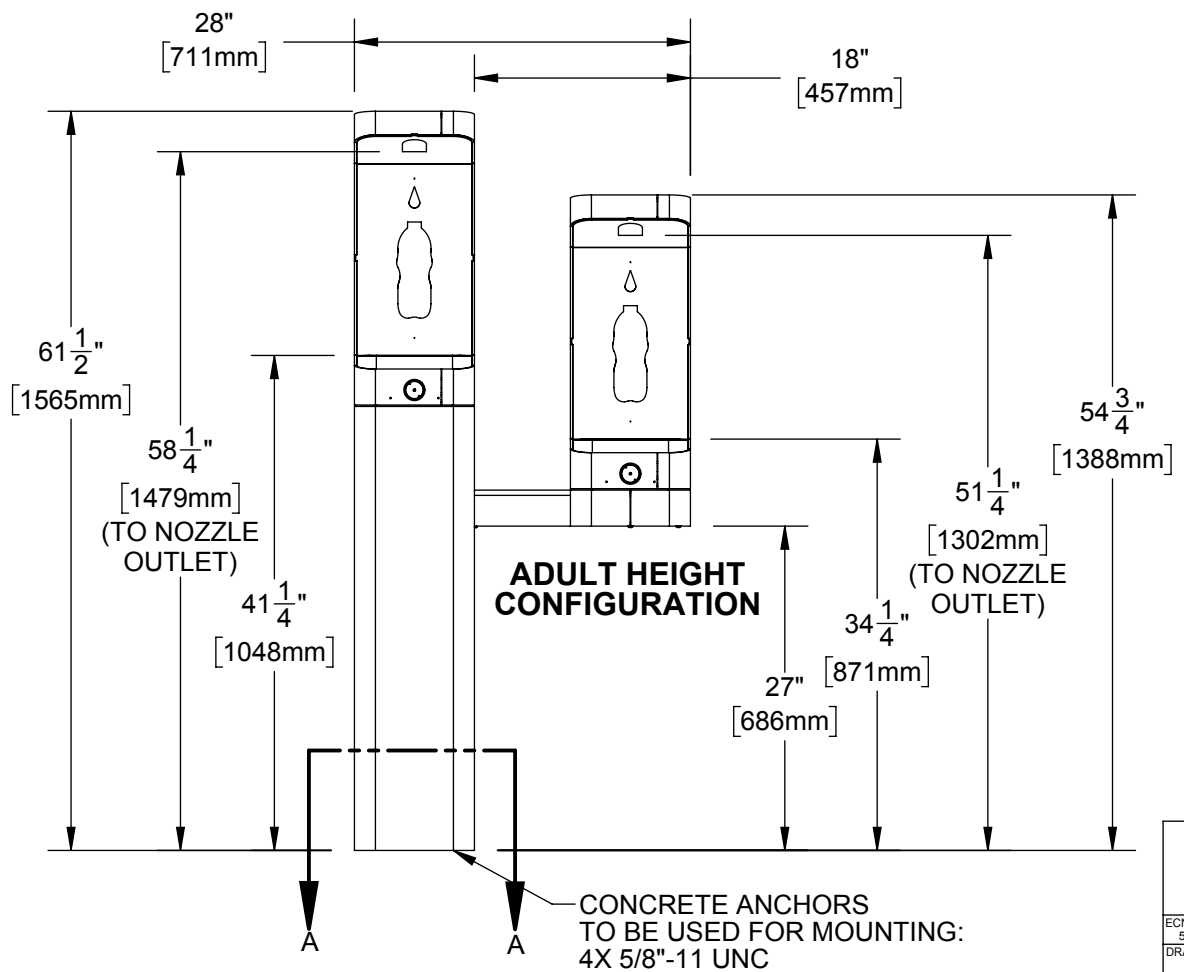

ADULT HEIGHT CONFIGURATION

CHILD HEIGHT CONFIGURATION

THIS UNIT CAN BE CONFIGURED TO INSTALL THE ARM AT A LOWER HEIGHT FOR CHILD USE

CONCRETE ANCHORS TO BE USED FOR MOUNTING: 4X 5/8"-11 UNC



1455 KLEPPE LANE
SPARKS, NEVADA 89431
(775) 359-4712 FAX (775) 359-7424
E-MAIL: HAWS@HAWSO.COM
WEBSITE: WWW.HAWSO.COM

ECN: 5226	REV. ECN: 5399	BY: MJ	MODEL(S)	PART NUMBER
DRAWN: MH	DATE: 03/06/17	CHKD: MH	3620 -MODULAR OUTDOOR FOUNTAIN SYSTEM	0510000757
APPROVED: IR	DATE: 02/19/19	SCALE: 1:16	DRAWING TYPE: INSTALLATION	REVISION
				2
				SHEET 1 OF 1