

### PRODUCT SPECIFICATIONS

Outdoor Bottle Filler Foot Pedal Accessory. Overall dimensions are 7-7/16" x 5" x 12-3/4".

<b>Finish:</b>	Black (BK), Blue (BLU), Evergreen (EVG), Gray (GRY)
<b>Dimensions:</b>	7-7/16" x 5" x 12-3/4"
<b>Shipping Weight:</b>	7 lbs.

**Special Note:** Need product compatibility info? Find model compatibility guide under the product downloads section.

- Convenient foot activation for healthier, hands-free bottle filling.
- Activates bottle filler only and will not activate attached fountains. Pedal will not deactivate the bottle filler push button.
- Attaches to lower access panel opening for secure connection and easy installation.
- Powder-coated exterior over Type 316 stainless steel provides protection from the elements.
- Available in 4 finishes to coordinate with outdoor tubular bottle filling stations.
- Compatible with select outdoor tubular bottle filling stations.

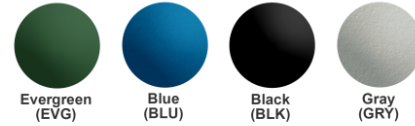

A Century of Tradition and Quality.

For more than 100 years, Elkay has been making innovative products and providing exceptional customer care. We take pride in offering plumbing products that make life easier, inspire change and leave the world a better place.



**Product Compliance:** ASME A112.18.1/CSA B125.1  
NSF 372 (lead free)  
NSF 61 (Q≤1)

[Installation Instructions \(PDF\) - 1000006191](#)  
[Installation Instructions \(PDF\) - Outdoor Foot Pedal Compatibility Guide](#)

PART: \_\_\_\_\_ QTY: \_\_\_\_\_

PROJECT: \_\_\_\_\_

CONTACT: \_\_\_\_\_

DATE: \_\_\_\_\_

NOTES: \_\_\_\_\_

APPROVAL: \_\_\_\_\_

*In keeping with our policy of continuing product improvement, Elkay reserves the right to change product specifications without notice. Please visit [elkay.com](http://elkay.com) for the most current version of Elkay product specification sheets. This specification describes an Elkay product with design, quality, and functional benefits to the user. When making a comparison of other producers' offerings, be certain these features are not overlooked.*

Parts List

ITEM NO.	PART NO.	DESCRIPTION
1	1000006138	ASSY, 4481 FP FOOT ACTIVATION
NS	28308C	WASHR-SPACER 2.00 O.D.
NS	40045C	NUT-HEX 1-5/16"
NS	10031C	1-1/8-24 RETAINING NUT
NS	1000004135	REGULATOR - HIGH FLOW WRAS
6	50985C	HOLDER-REGULATOR
7	45663C	SLEEVE - PUSH BUTTON GUIDE
8	45960C	BUTTON - PUSH W/O HOLE
9	55994C	TUBE-POLY 1/4X.040 WALL
10	1000004069	STRAINER-IN LINE WRAS
11	62223C	TUBE-CU 3/8 X 4.75 (1-P117)
12	70852C	FTTNG TEE - 3/8
13	70745C	FTTNG-UNION-3/8 X 1/4 UNION
14	56307C	TUBE-POLY 3/8X.062 WALL
15	50090C	INSULATOR-ARMAFLEX
16	75672C	SCREW-CAP #6-32
17	101461040560	INSULATOR-TUBE 3/8-3/16 BULK

NS = Not Shown

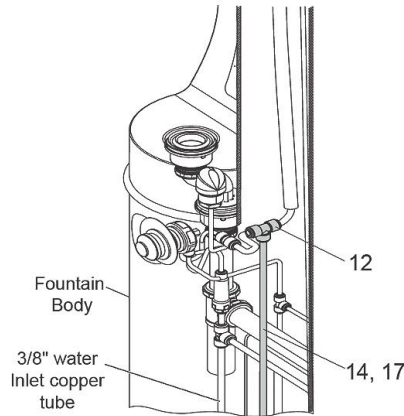
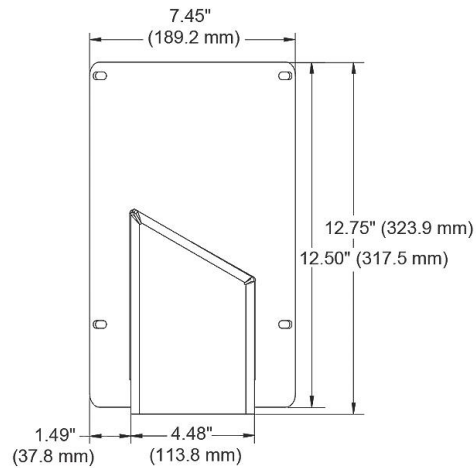

Upper Fountain Bottle Filler Internal View

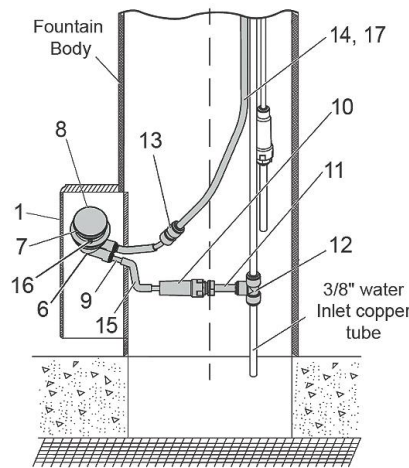
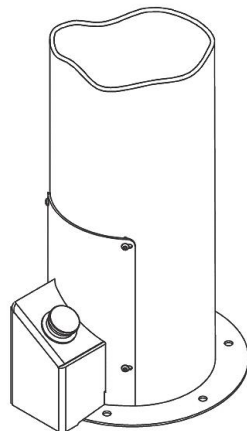
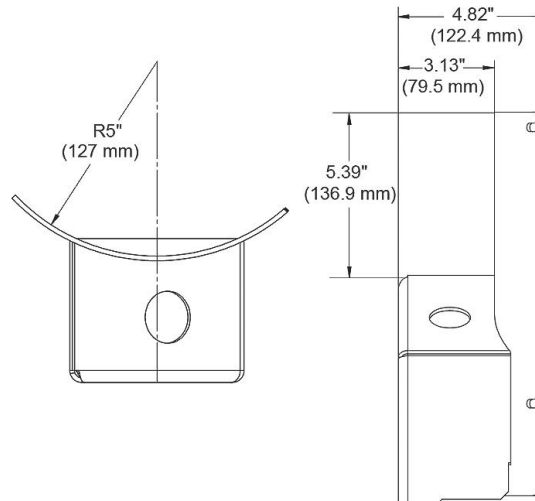

Lower Fountain Internal View

In keeping with our policy of continuing product improvement, Elkay reserves the right to change product specifications without notice. Please visit [elkay.com](http://elkay.com) for the most current version of Elkay product specification sheets. This specification describes an Elkay product with design, quality, and functional benefits to the user. When making a comparison of other producers' offerings, be certain these features are not overlooked.