

Installation/Care/Use Manual

Composite Fountain with FLEXI-GUARD®

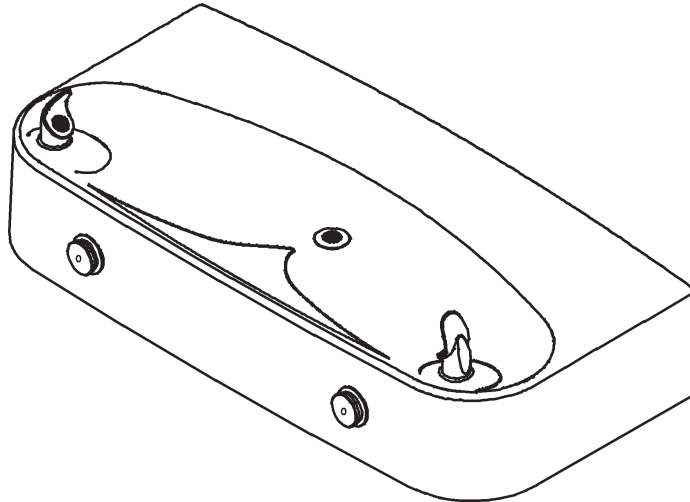

Installer

To assure you install this model easily and correctly, PLEASE READ THESE SIMPLE INSTRUCTIONS BEFORE STARTING THE INSTALLATION. CHECK YOUR INSTALLATION FOR COMPLIANCE WITH PLUMBING, ELECTRICAL AND OTHER APPLICABLE CODES. After installation, leave these instructions inside the fountain for future reference.

IMPORTANT

ALL SERVICE TO BE PERFORMED BY AN AUTHORIZED SERVICE PERSON

IMPORTANT! INSTALLER PLEASE NOTE.

THE GROUNDING OF ELECTRICAL EQUIPMENT SUCH AS TELEPHONE, COMPUTERS, ETC. TO WATER LINES IS A COMMON PROCEDURE. THIS GROUNDING MAY BE IN THE BUILDING OR MAY OCCUR AWAY FROM THE BUILDING. THIS GROUNDING CAN CAUSE ELECTRICAL FEEDBACK INTO A FOUNTAIN, CREATING AN ELECTROLYSIS WHICH CAUSES A METALLIC TASTE OR AN INCREASE IN THE METAL CONTENT OF THE WATER. THIS CONDITION IS AVOIDABLE BY USING THE PROPER MATERIALS AS INDICATED. ANY DRAIN FITTINGS PROVIDED BY THE INSTALLER SHOULD BE MADE OF PLASTIC TO ELECTRICALLY ISOLATE THE FOUNTAIN FROM THE BUILDING PLUMBING SYSTEM.

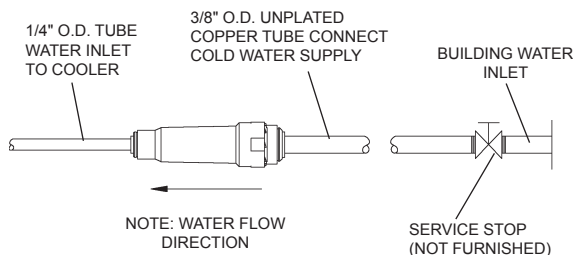

FIG. 1

OPERATION OF QUICK CONNECT FITTINGS

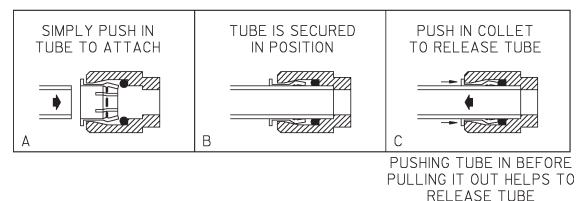

FIG. 2

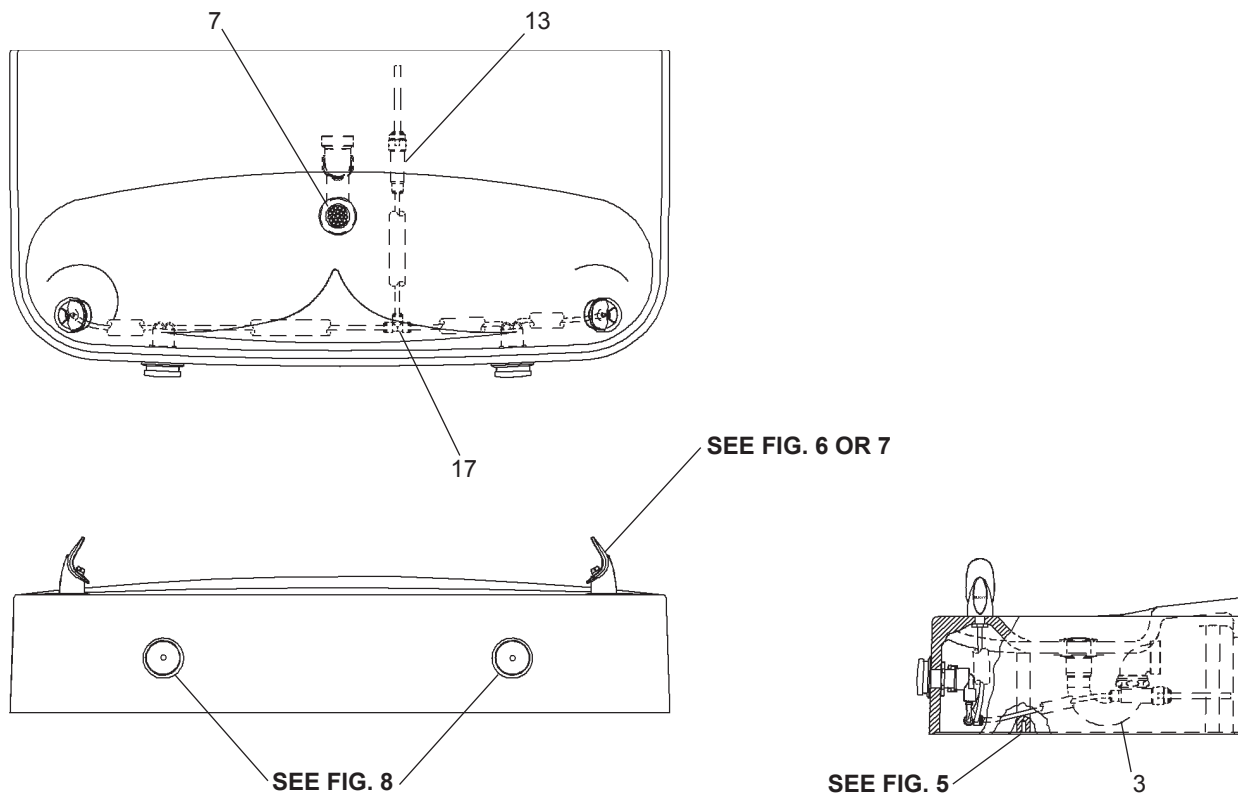

FIG. 4

INSTALLATION INSTRUCTIONS

1. **Wall** should already be framed for the fountain using the positioning dimensions shown in Figure 3. Shown dimensions pertain to installation location (framing must support up to 150 lbs. weight). These dimensions are required for compliance with ANSI Standard A117.0.
2. **Install** rough-in plumbing as shown in Figure 3. Run the supply water inlet line and connect to a service stop (not provided). Turn on supply water and flush thoroughly.
3. **Remove** bottom access panel from fountain basin and save the screws. Install the fountain to the wall using (7) 5/16" bolts and washers (not provided). Bolts should be long enough to securely fasten the fountain to the wall. Tighten securely, but do not over tighten. Over tightening will crack the fountain.
4. **Remove** elbow from end of p-trap and attach it to drain tube. Reattach elbow to p-trap and cut waste tube to required length using plumbing hardware and trap as a guide.
5. **Make** water supply connections from service stop to the 3/8" O.D. unplated copper tube coming out of the strainer. Turn on water supply and check for leaks. Newly installed water supply line should be insulated after leak check is completed. **DO NOT SOLDER TUBES INSERTED INTO THE STRAINER AS DAMAGE TO THE O-RINGS MAY RESULT.**
6. **These** products are designed to operate on 20-105 PSI supply line pressure. If inlet pressure is above 105 PSI, a pressure regulator must be installed in the supply line. Any damage caused by reason of connecting these products to supply line pressures lower than 20 PSI or higher than 105 PSI is not covered by warranty.
7. **Check** stream height from bubbler. Stream height is factory set at 35 PSI. If supply pressure varies greatly from this, adjust the screw on the regulator (Item 4, Fig 8), by using a small screw driver through the small hole in the push button (Item 8). Clockwise adjustment will raise stream height and counter-clockwise will lower stream height. For best adjustment stream should hit basin approximately 6-1/2" (165mm) from bubbler.
8. **Replace** bottom access panel to fountain using the screws provided. Tighten securely.

CARE AND MAINTENANCE OF ELKAY COMPOSITE FOUNTAINS

1. **Elkay** composite fountains provide an extremely durable, nonporous surface which resists staining. Care is very simple. Routine cleaning with a soft sponge or cloth, or with water or a non-abrasive aerosol foam cleaner, is all that is normally needed to give many years of trouble free service. Cleaners left standing on the fountain surface can dull the surface finish. Be certain to rinse all cleaning agents completely and polish with a soft cloth.
2. **Harsh** abrasive cleaners are not required and should not be used.
3. **Mild** abrasives such as liquid automotive cleaning compound or baking soda paste will remove simple scratches and stains. Cigarette burns can normally be removed without noticeable effect. Deeper scratches or gouges can be corrected with fine grit sandpaper (240 grit then 400 grit) or a green scotchbrite pad.
4. **To maintain** or regain luster and make cleaning easier, periodic applications of automobile wax or like products will keep the finish looking like new.

TROUBLE SHOOTING AND MAINTENANCE

1. **Orifice Assy:** Mineral deposits on orifice can cause water flow to spurt or not regulate. Mineral deposits may be removed from orifice with a small round file not over 1/8" diameter or a small diameter wire.
CAUTION: Do not file or cut orifice materials.
2. **Stream Regulator:** If orifice is free of material deposits, regulate flow according to instruction 7 stated above.
3. **Actuation of Quick Connect Water Fittings:** Cooler is provided with lead-free connectors which utilize an o-ring water seal. To remove tubing from the fitting, relieve water pressure, push in on the gray collar while pulling on the tubing (See Figure 2). To insert tubing, push tube straight into the fitting until it reaches a positive stop, approximately 3/4".

PARTS LIST		
ITEM NO	PART NO.	DESCRIPTION
1	40322C	ORIFICE ASSEMBLY
2	55998C	BUBBLER PEDESTAL
3	LK464	DRAIN
4	98731C	REGULATOR/HOLDER/NUTS
5	27635C	BOTTOM COVER
6	45736C	NUT - REGULATOR MOUNTING
7	45391C	DRAIN FERRULE
8	45662C	PUSH BUTTON
9	45738C	PUSH BUTTON SLEEVE
10	75575C	BALL - ANTI-ROTATIONAL
11	56011C	BUBBLER HOUSING
12	56087C	PUSH BUTTON EXTENSION
13	55996C	STRAINER
14	75554C	THREADED INSERT
15	1000004652	BUBBLER ASSY (VR MODEL ONLY)
16	75672C	SCREW - CAP #6-32 X 5/16
17	1000001994	KIT - TEE - 1/4 (3 PACK)
18	75534C	SCREW - #10-24 PINNED TORX
19	75553C	HEX NUT - 3/8-18
NS	56092C	POLY TUBING (CUT TO LENGTH)

NS = NOT SHOWN

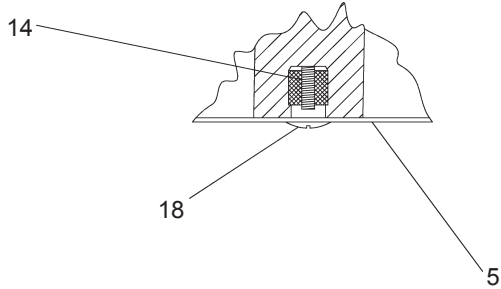

FIG. 5

FIG. 6

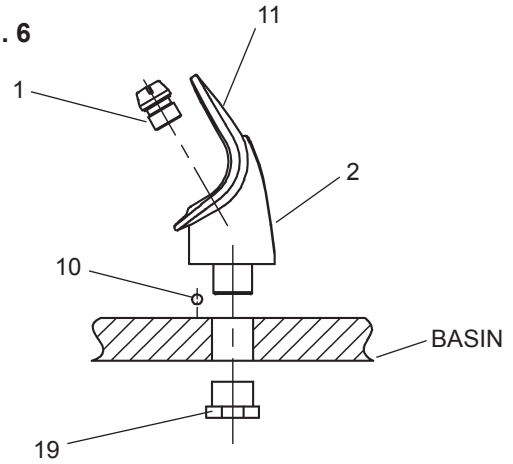
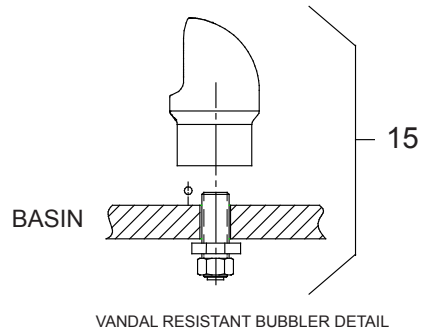

FIG. 7



VANDAL RESISTANT BUBBLER DETAIL

NOTE: WHEN INSTALLING REPLACEMENT BUBBLER AND PEDESTAL, TIGHTEN NUT (ITEM 19) ONLY TO HOLD PARTS SNUG IN POSITION. **DO NOT OVER TIGHTEN.**

FIG. 8

