

PRODUCT SPECIFICATIONS

Elkay Water Dispenser Hot Filtered Refrigerated 1.5 GPH Stainless Steel. Features shall include Ambient Water, Chilled Water, Filtered, Hot Water, Sparkling Water, UV Light. Front Button activation with Dry Cooling technology. Product shall be Countertop mounted/Freestanding.

Special Features:	Ambient Water, Chilled Water, Filtered, Hot Water, Sparkling Water, UV Light
Model Type:	Countertop
Material:	Stainless Steel
Dimensions (L x W x H):	19-3/16" x 10-1/4" x 16-7/16"
Approx. Shipping Weight:	80 lbs.
Cold Water Temperature Range:	42° F – 50° F
Cooling Capacity:	1.5 GPH (32.6 oz. cups/hour)
Cooling Technology:	Aluminum fusion block heat exchanger
Refrigerant Gas:	R134a
Condensation Control:	Forced ventilation (fan)
Hot Water Temperature:	185° F
Hot Water Tank Capacity:	0.265 gallons
Heater Rating:	1000 W
Inlet Water Line:	1/4", PE plastic tubing
Electrical:	115V/60Hz
Power Consumption:	1200 W
Working Room Temperature:	Min 41° F – Max 107° F
Filter Capacity:	6000 gallons or 6 months
*Based on 68° F inlet water & 77° F ambient air temp for 50° F chilled drinking water.	

- Three water dispensing options: chilled water, hot water, and sparkling water.
- Filter is certified to NSF 42 and 53 for lead, particulate, chlorine, taste, and odor reduction.
- UV Light prohibits bacterial growth on dispense nozzle.
- Drip tray included: no drain line required.
- Fast fill rate 1.1 GPM.

INSTALLATION KIT

- Installation and Operating instructions
- CO₂ Regulator
- Water Pressure Regulator
- Elkay WaterSentry® Filter and Mounting Bracket
- Additional tubing for connection to water and CO₂
- Requires fittings for connection to water supply
- Shut-off Valve

PART: _____ QTY: _____

PROJECT: _____

CONTACT: _____

DATE: _____

NOTES: _____

APPROVAL: _____



A Century of Tradition and Quality. For more than 100 years, Elkay has been making innovative products and providing exceptional customer care. We take pride in offering plumbing products that make life easier, inspire change and leave the world a better place.

Included with Product: Installation Kit

PRODUCT COMPLIANCE

CAN/CSA C22.2 No. 120

NSF/ANSI 42, 53, 61, & 372 (lead free)

UL 399





Intertek

[Installation Instructions \(PDF\) - 100003719](#)

[Warranty \(PDF\)](#)

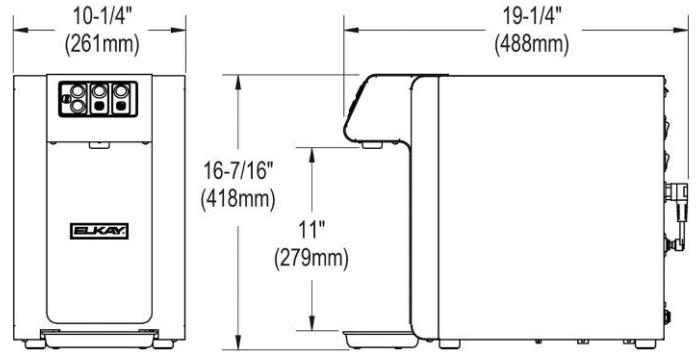
In keeping with our policy of continuing product improvement, Elkay reserves the right to change product specifications without notice. Please visit elkay.com for the most current version of Elkay product specification sheets. This specification describes an Elkay product with design, quality, and functional benefits to the user. When making a comparison of other producers' offerings, be certain these features are not overlooked.



Optional Accessories		
DSCABBSH	Elkay Water Dispenser Cabinet Spec Sheet (PDF)	
51300C	Elkay WaterSentry Replacement Filter (Bottle Fillers & Liv Pro) Spec Sheet (PDF)	

In keeping with our policy of continuing product improvement, Elkay reserves the right to change product specifications without notice. Please visit elkay.com for the most current version of Elkay product specification sheets. This specification describes an Elkay product with design, quality, and functional benefits to the user. When making a comparison of other producers' offerings, be certain these features are not overlooked.