

**PRODUCT SPECIFICATIONS**

Elkay Water Dispenser Hot Filtered Refrigerated 4 GPH Stainless Steel. Features shall include Chilled Water, Energy Savings, Filtered, Hot Water, Sparkling Water, UV Light. Product shall be Countertop mounted/Freestanding.

<b>Special Features:</b>	Chilled Water, Energy Savings, Filtered, Hot Water, Sparkling Water, UV Light
<b>Model Type:</b>	Countertop
<b>Material:</b>	Stainless Steel
<b>Dimensions (L x W x H):</b>	19-1/4" x 13" x 18-3/8"
<b>Approx. Shipping Weight:</b>	88 lbs.
<b>Cold Water Temperature Range:</b>	42° F – 48° F
<b>Cooling Capacity:</b>	4.0 GPH (85.6 oz. cups/hour)
<b>Cooling Technology:</b>	IceBank Heat Exchanger
<b>Refrigerant Gas:</b>	R134a
<b>Condensation Control:</b>	Forced ventilation (fan)
<b>Hot Water Temperature:</b>	185° F
<b>Hot Water Tank Capacity:</b>	0.265 gallons
<b>Heater Rating:</b>	1000 W
<b>Inlet Water Line:</b>	3/8", PE plastic tubing
<b>Electrical:</b>	115V/60Hz
<b>Power Consumption:</b>	1350 W
<b>Working Room Temperature:</b>	Min 41° F – Max 107° F
<b>Filter Capacity:</b>	6000 gallons or 6 months
*Based on 68° F inlet water & 77° F ambient air temp for 50° F chilled drinking water.	

- Three water dispensing options: chilled water, hot water, and sparkling water.
- Filter is certified to NSF 42 and 53 for lead, particulate, chlorine, taste, and odor reduction.
- UV Light prohibits bacterial growth on dispense nozzle.
- Energy-Savings mode reduces energy consumption by up to 75%.
- Includes hot water safety latch.
- CO<sub>2</sub> and H<sub>2</sub>O display alarms.
- Internal ice bank and adjustable thermostat.
- Drip tray included: no drain line required.
- Fast fill rate 1 GPM.

**INSTALLATION KIT**

- Installation and Operating instructions
- CO<sub>2</sub> Regulator
- Water Pressure Regulator
- Elkay WaterSentry® Filter and Mounting Bracket
- Additional tubing for connection to water and CO<sub>2</sub>

PART: \_\_\_\_\_ QTY: \_\_\_\_\_

PROJECT: \_\_\_\_\_

CONTACT: \_\_\_\_\_

DATE: \_\_\_\_\_

NOTES: \_\_\_\_\_

APPROVAL: \_\_\_\_\_



A Century of Tradition and Quality. For more than 100 years, Elkay has been making innovative products and providing exceptional customer care. We take pride in offering plumbing products that make life easier, inspire change and leave the world a better place.

**Included with Product:** Installation Kit

**PRODUCT COMPLIANCE**

CAN/CSA C22.2 No. 120

NSF/ANSI 42, 53, 61, & 372 (lead free)

UL 399



Intertek



[Installation Instructions \(PDF\) - 1000003740](#)

[Warranty \(PDF\)](#)

*In keeping with our policy of continuing product improvement, Elkay reserves the right to change product specifications without notice. Please visit elkay.com for the most current version of Elkay product specification sheets. This specification describes an Elkay product with design, quality, and functional benefits to the user. When making a comparison of other producers' offerings, be certain these features are not overlooked.*

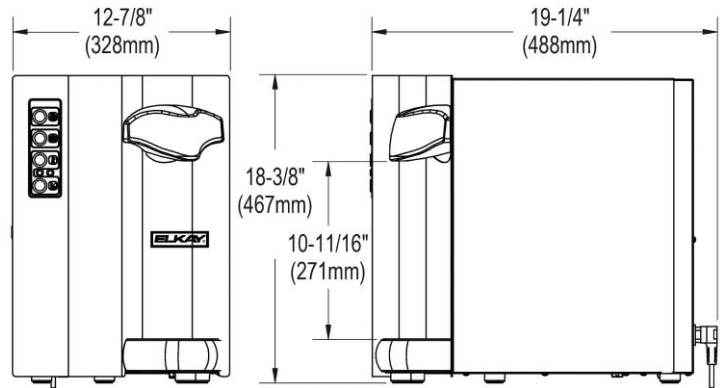
- Requires fittings for connection to water supply



Optional Accessories		
<a href="#">DSCABWH</a>	Elkay Water Dispenser Cabinet <a href="#">Spec Sheet (PDF)</a>	
<a href="#">51300C</a>	Elkay WaterSentry Replacement Filter (Bottle Fillers & Liv Pro) <a href="#">Spec Sheet (PDF)</a>	

*In keeping with our policy of continuing product improvement, Elkay reserves the right to change product specifications without notice. Please visit [elkay.com](http://elkay.com) for the most current version of Elkay product specification sheets. This specification describes an Elkay product with design, quality, and functional benefits to the user. When making a comparison of other producers' offerings, be certain these features are not overlooked.*