



model 1001HPSMS

Wall-Mounted Drinking Fountain

FEATURES & BENEFITS

QUALITY CONTROL

Fountain is pre-built and fully water and pressure tested to ensure no leaks and proper function for reduced installation time and added peace of mind.

CONSTRUCTION

18 gauge Type 304 Stainless Steel swirl design bowl, 14 gauge Type 304 Stainless Steel bracket, and a vandal-resistant bottom plate provides a long lasting unit with added peace of mind.

BUBBLER HEAD

Polished chrome-plated brass bubbler head with integral laminar flow prevents splashing and provides a superior flow pattern. The integral basin shank and inserted roll pin adds vandal resistance strength to the design, and the shielded angled stream orifice produces a steady sanitary source of water.

MOUNTING

Galvanized frame and 10 gauge surface plate provide the maximum mounting strength for the single bubbler MS style Haws drinking fountains.

PUSH BUTTON

With its patented (Pat. # 6,981,692) stainless steel, push-button activated valve assembly which allows for front access stream adjustment as well as cartridge and strainer access, this fountain offers 100% lead free waterways. The valve works at an operating pressure range of 30 to 90 psi (2.1 to 6.2 bar).

OPTIONS

- ❑ Filter: Model 6426, 12" x 2" (30.5 x 5.1 cm), in-line lead removal element that reduces lead from incoming water supply.
- ❑ Chiller: Model HCR8, 8 gph (30.3 L) remote water chiller provides instantaneous cooling to meet a continuous demand for chilled water.

To see all options for this model, visit www.hawsc.com



SPECIFICATIONS

Model 1001HPSMS wall mounted barrier-free drinking fountain shall include an 18 gauge Type 304 high-polished stainless steel finish basin with integral swirl design, 14 gauge Type 304 high-polished stainless steel wall bracket, with matching back and access panel allowing for front access of P-trap and stop, 100% lead-free waterways, in-wall mounting frame, push-button operated stainless steel valve with front-accessible cartridge and flow adjustment, polished chrome-plated brass vandal-resistant bubbler head with integral laminar anti-squirt flow, chrome-plated brass vandal-resistant waste strainer, vandal-resistant bottom plate, and 1-1/4" O.D. (3.2 cm) waste pipe.

APPLICATIONS

Perfect for either public or private indoor/outdoor settings, Model 1001HPSMS is a great fit in areas where aesthetics are important to the overall appeal of the architecture. This series is precisely mounted, making it a nice addition to any surrounding. Beautiful high-polished finish helps to maintain the fountains overall appeal so it always remains looking as new as it did when it was installed. Specifically, this type of wall mounted drinking fountain may be placed in settings such as: schools and other locations in and around office buildings where the temperature remains above freezing.

Model meets all current Federal Regulations for the disabled including those in the Americans with Disabilities Act. Haws manufactures drinking fountains and electric water coolers to be lead-free by all known definitions including NSF/ANSI Standard 61, Section 9, California Proposition 65, and the Federal Safe Drinking Water Act. Product is compliant to California Health and Safety Code 116875 (AB 1953-2006).



NOTES:

1. HOLD ROUGH-IN DIMENSIONS $\pm 1/8"$ (3.2mm).
2. WHEN INSTALLING THIS UNIT, LOCAL, STATE, OR FEDERAL CODES SHOULD BE ADHERED TO FOR INSTALLATION DIMENSIONS (LOCATIONS), WASTE AND SUPPLY REQUIREMENTS OTHER THAN SHOWN.
3. ** INSTALLER MUST PROVIDE TRAP FOR PROPER INSTALLATION.

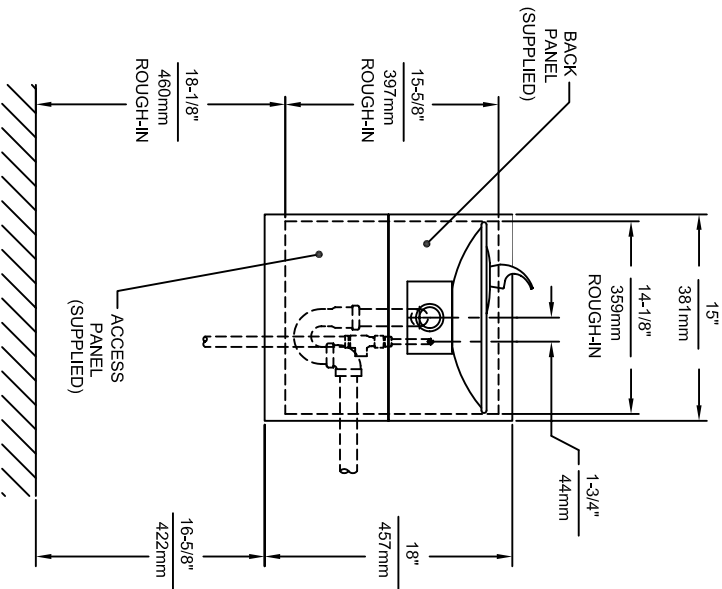

REMOVE VALVE FROM PUSH BUTTON TO INSTALL WASTE ELBOW ONTO BOWL. AFTER WASTE ELBOW IS INSTALLED, REINSTALL VALVE & ADJUST FLOW

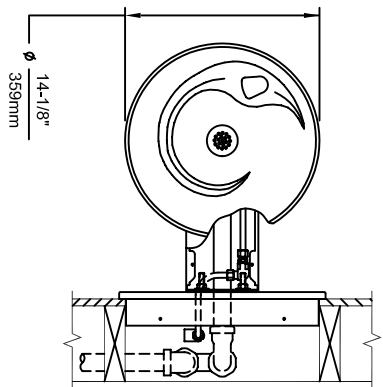

IMPORTANT: MOUNTING FRAME MUST BE INSTALLED SO THAT FRAME FLANGE BUTTS AGAINST FINISHED WALL FACE.

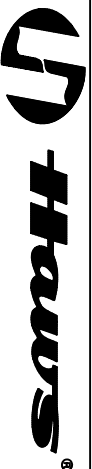
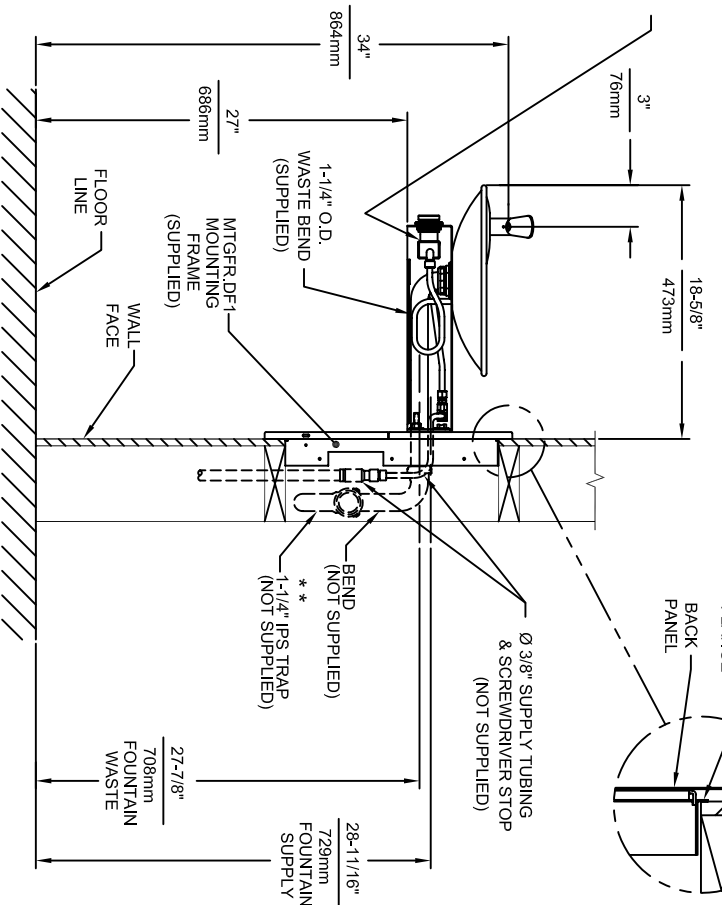

1455 KLEPPE LANE
SPARKS, NEVADA 89431
(775) 359-4712 FAX (775) 359-7424
EMAIL: HAWS@HAWS.CO.COM
WEBSITE: WWW.HAWS.CO.COM

EQUIV. NO. REVISED PER BY:	MODEL(S)	PART NUMBER
DRAWN: ECK, 4/73 HM	1001MS/1001HPSMS	0002076510.D
DATE: 08/27/93	DRINKING FOUNTAIN	DRAWING NO.: REV
APPROVED: [Signature]	SCALE: 1/16"	DRAWING TYPE: INSTALLATION
		SIZE: A SHEET: 1 OF 1