



model 1011HO

ADA Dual Wall Mount Touchless/Push Button Fountain

FEATURES & BENEFITS

CONSTRUCTION

Rugged ADA accessible 18 gauge Type 304 Stainless Steel swirl design bowls, 14 gauge Type 304 Stainless Steel brackets, and a vandal-resistant bottom plate provides a long lasting unit with added peace of mind.

HANDS FREE

Touchless operation for safety and peace of mind

BACK PANEL

Stainless steel back panel helps to protect the wall from inadvertent splashing, and its decorative satin finish increases location visibility.

MOUNTING

3/16" (.47 cm) steel mounting plate with supplied mounting hardware for a solid unit base allows for easy installation to a framed wall. (P-trap and stop require rear access)

BUBBLER HEAD

Polished chrome-plated brass bubbler heads with integral laminar flow prevents splashing while providing a superior flow pattern. The integral 11/16" dia. basin shank and stainless anti-rotation roll pin for vandal resistance strength. Shielded, angled stream opening provides a steady source of drinking water at .45 gpm.

DRINKING FOUNTAIN VALVE

Fountain incorporates a touchless sensor operated stainless steel solenoid valve controlled by a transformer on one side and a push-button activated valve which offers the only all stainless steel valve body that is machined out of solid bar stock and is fully serviceable through the front of the push button assembly offering access to the water control cartridge and integral water supply strainer on the other.



SPECIFICATIONS

Model 1011HO Hi-Lo wall mounted ADA combination touchless/push button drinking fountain shall include dual 18 gauge Type 304 Stainless Steel satin finish basins with integral swirl design, 14 gauge Type 304 Stainless Steel wall brackets, 100% lead-free waterways, touchless sensor operated solenoid valve on one side, and push-button operated stainless steel valve with front-accessible cartridge and flow adjustment on the other, polished chrome-plated brass vandal-resistant bubbler heads with integral laminar anti-squirt flow, chrome-plated brass vandal-resistant waste strainers, vandal-resistant bottom plates, stainless steel satin finish back panel, high and low fountain mounting levels, and 1-1/4" O.D. (3.2 cm) waste pipes. (P-trap and stop require rear access) **REQUIRES MODEL 6700.4 PRICED SEPARATELY.**

OPTIONS

- Bottle Filler: Model 1920HO, bottle filler can be a standalone station, or mounted above Haws 1001, 1011, 1107L, 1109, 1117L, and 1119 series drinking fountain models.
Water Filter: Model 6426, 12" x 2" (30.5 x 5.1 cm), in-line lead
- removal element that reduces lead from incoming water supply.
Access Panel: Model 6603, satin finish stainless steel access
- panel. Includes frame and screws.
Support Frame: Model 6800 universal in-wall mounting
- support for use with most fountains.

For more information, visit www.hawsc.com or call (888) 640-4297.

APPLICATIONS

Perfect for either public or private indoor/outdoor settings, Model 1011HO is a great fit in areas where aesthetics are important to the overall appeal of the architecture. This series is precisely mounted, making it a nice addition to any surrounding. Beautiful satin finish helps to maintain the fountains overall appeal, so it always remains looking as new as it did when it was installed. Specifically, this type of wall mounted drinking fountain may be placed in settings such as: schools and other locations in and around office buildings where the temperature remains above freezing. Model meets all current Federal Regulations for the disabled including those in the Americans with Disabilities Act. Haws manufactures drinking fountains and electric water coolers to be lead-free by all known definitions including NSF/ANSI Standard 61, Section 9, NSF/ANSI 372, California Proposition 65, and the Federal Safe Drinking Water Act. Product is compliant to California Health and Safety Code 116875 (AB 1953-2006) as evaluated by CSA International.



- NOTES:
1. HOLD ROUGH-IN DIMENSIONS $\pm 1/8"$ (3.2mm).
 2. WHEN INSTALLING THIS UNIT, LOCAL, STATE, OR FEDERAL CODES SHOULD BE ADHERED TO FOR INSTALLATION DIMENSIONS (LOCATIONS), WASTE AND SUPPLY REQUIREMENTS OTHER THAN SHOWN.
 3. INSTALLER MUST PROVIDE TRAP FOR PROPER INSTALLATION.
 4. REMOVE VALVE FROM PUSH BUTTON TO INSTALL WASTE ELBOW ONTO BOWL. AFTER WASTE ELBOW IS INSTALLED, REINSTALL VALVE AND ADJUST FLOW.
 5. REFER TO 6874 SERIES OPERATION AND MAINTENANCE MANUAL FOR PUSH BUTTON AND VALVE INSTALLATION/MAINTENANCE INSTRUCTIONS, OR TO OPERATORS' MANUAL FOR SENSOR INSTRUCTIONS.

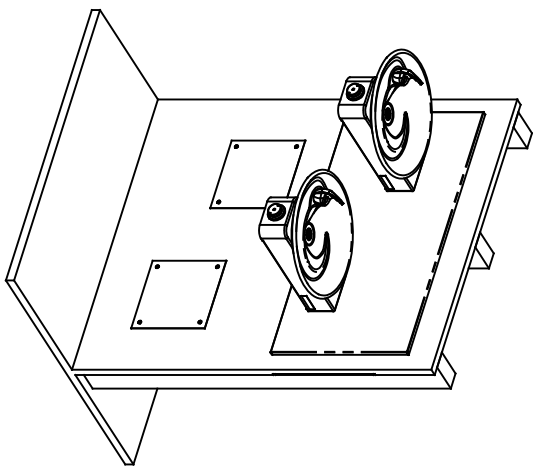
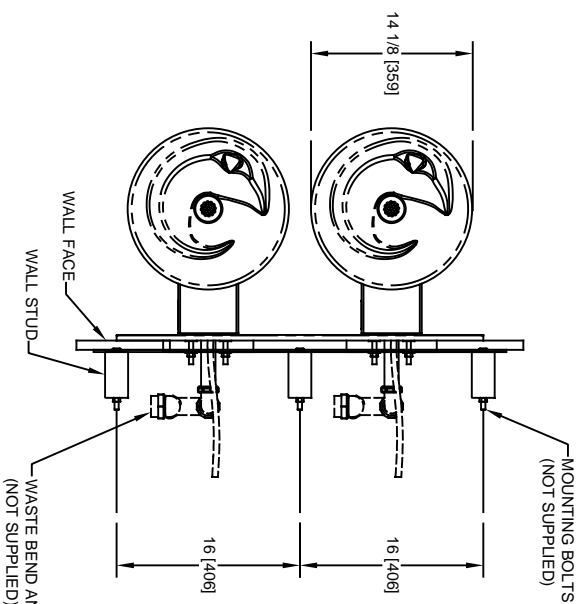
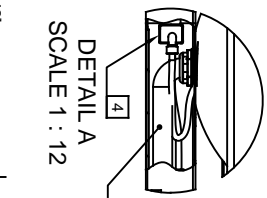

Available with hands off sensor in lieu of push button valve.

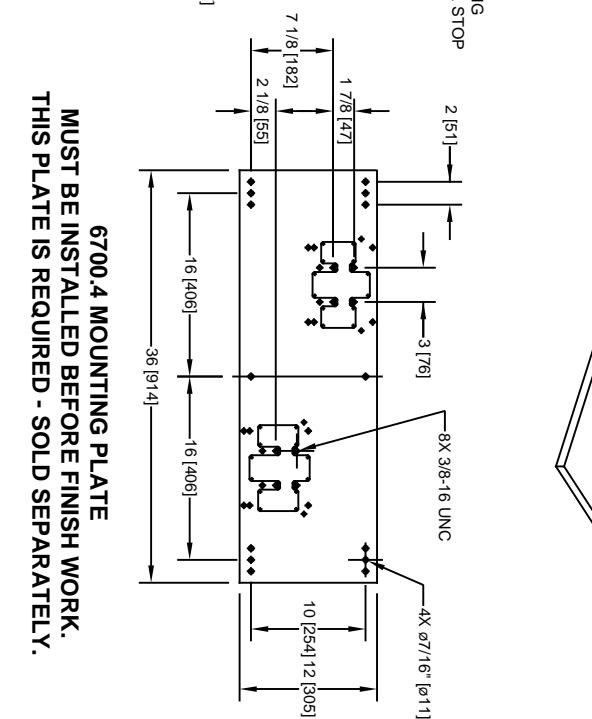
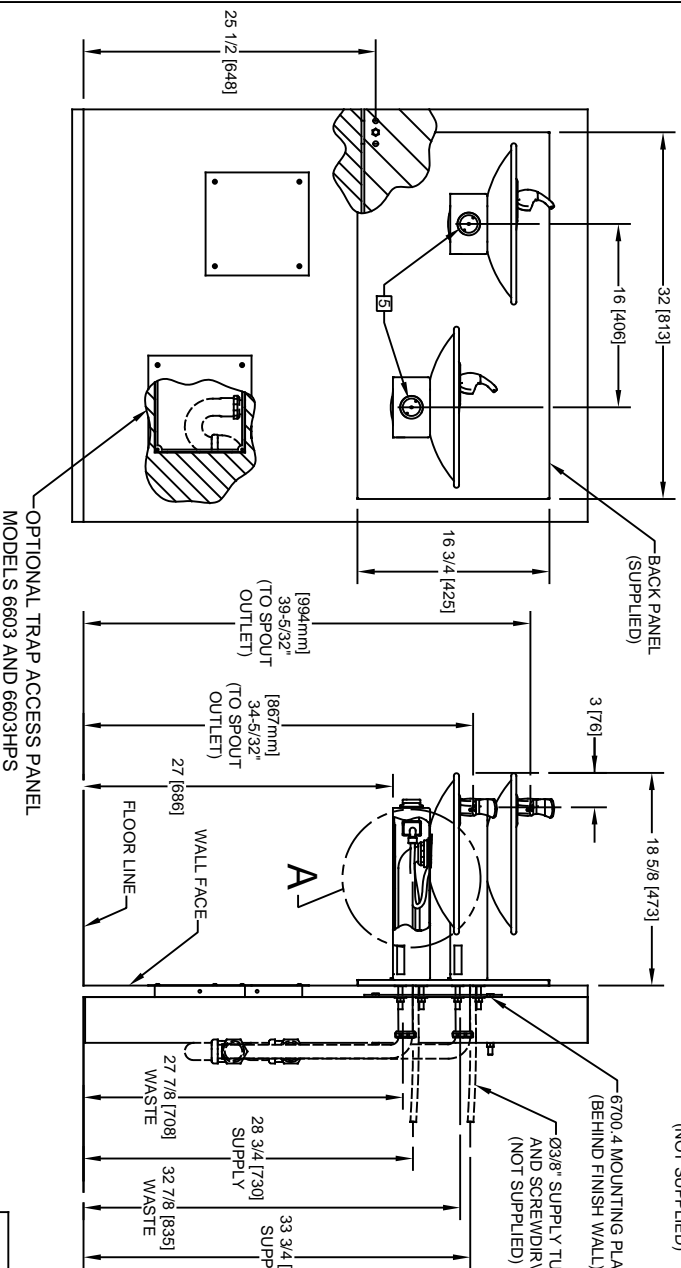

6700.4 MOUNTING PLATE MUST BE INSTALLED BEFORE FINISH WORK. THIS PLATE IS REQUIRED - SOLD SEPARATELY.



HAWWS

1456 KLEPPE LANE
SPARKS, NEVADA 89431
(775) 359-4712 FAX (775) 359-7424
E-MAIL: HAWWS@HAWSCO.COM
WEBSITE: WWW.HAWSCO.COM

ECN NO. REVISED PER BY:	MODEL(S)	1011/1011HO
DRAWN: RM	DATE: 05/28/08	SCALE: 1:1
CHKD: DP	DATE: 03/28/20	DRAWING TYPE: INSTALLATION
APPROVED: NE	DATE: 03/28/20	SIZE: A
PART NUMBER: 0002076520.D	REVISION: 21	SHEET: 1 OF 1