



model 1011HPSMS

Wall-Mounted Drinking Fountain

FEATURES & BENEFITS

QUALITY CONTROL

Both fountains are pre-built and fully water and pressure tested to ensure no leaks and proper function for reduced installation time and added peace of mind.

CONSTRUCTION

18 gauge Type 304 Stainless Steel swirl design bowl, 14 gauge Type 304 Stainless Steel bracket, and a vandal-resistant bottom plate provides a long lasting unit with added peace of mind.

BUBBLER HEAD

Polished chrome-plated brass bubbler head with integral laminar flow prevents splashing and provides a superior flow pattern. The integral basin shank and inserted roll pin adds vandal resistance strength to the design, and the shielded angled stream orifice produces a steady sanitary source of water.

MOUNTING

Galvanized frame and 10 gauge surface plate provide the maximum mounting strength for the 'Hi-Lo' MS style Haws drinking fountains.

PUSH BUTTON

With its patented (Pat. # 6,981,692) stainless steel, push-button activated valve assembly which allows for front access stream adjustment as well as cartridge and strainer access, this fountain offers 100% lead free waterways. The valve works at an operating pressure range of 30 to 90 psi (2.1 to 6.2 bar).

OPTIONS

- ❑ Filter: Model 6426, 12" x 2" (30.5 x 5.1 cm), in-line lead removal element that reduces lead from incoming water supply.
- ❑ Cane Touch Skirt: Model SK3HPS, high polished stainless steel cane touch skirt for installation on high unit to comply with ADA protruding objects guidelines.
- ❑ Chiller: Model HCR8, 8 gph (30.3 L) remote water chiller provides instantaneous cooling to meet a continuous demand for chilled water.

To see all options for this model, visit www.hawsc.com



SPECIFICATIONS

Model 1011HPSMS "Hi-Lo" wall mounted barrier-free drinking fountain shall include dual 18 gauge Type 304 high-polished stainless steel finish basins with integral swirl design, 14 gauge Type 304 high-polished stainless steel wall bracket, 100% lead-free waterways, push-button operated stainless steel valves with front-accessible cartridge and flow adjustment, polished chrome-plated brass vandal-resistant bubbler heads with integral laminar anti-squirt flow, chrome-plated brass vandal-resistant waste strainers, vandal-resistant bottom plates, high-polished stainless steel finish back and access panels allowing for front access of P-trap and stop, in-wall mounting frame, high and low fountain mounting levels, and 1-1/4" O.D. (3.2 cm) waste pipes.

APPLICATIONS

Perfect for either public or private indoor/outdoor settings, Model 1011HPSMS is a great fit in areas where aesthetics are important to the overall appeal of the architecture. This series is precisely mounted, making it a nice addition to any surrounding. Beautiful high-polished finish helps to maintain the fountains overall appeal so it always remains looking as new as it did when it was installed. Specifically, this type of wall mounted drinking fountain may be placed in settings such as: schools and other locations in and around office buildings where the temperature remains above freezing.

Model meets all current Federal Regulations for the disabled including those in the Americans with Disabilities Act. Haws manufactures drinking fountains and electric water coolers to be lead-free by all known definitions including NSF/ANSI Standard 61, Section 9, California Proposition 65, and the Federal Safe Drinking Water Act. Product is compliant to California Health and Safety Code 116875 (AB 1953-2006) as evaluated by CSA International.



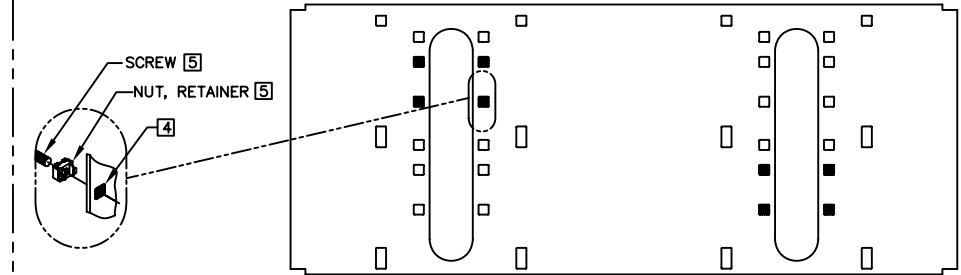
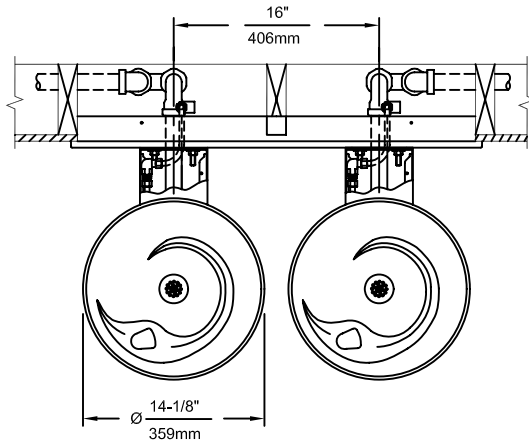

BOWL MOUNTING PATTERN DETAIL

NOTES:

- 1. HOLD ROUGH-IN DIMENSIONS ±1/8" (3.2mm).
- 2. WHEN INSTALLING THIS UNIT, LOCAL, STATE, OR FEDERAL CODES SHOULD BE ADHERED TO FOR DIMENSIONS (LOCATIONS), WASTE AND SUPPLY REQUIREMENTS OTHER THAN SHOWN.
- 3. INSTALLER MUST PROVIDE TRAP FOR PROPER INSTALLATION.
- 4. HOLE COMBINATION SHOWN BELOW IS FOR USE WITH LOW FOUNTAIN ON THE RIGHT AND HIGH FOUNTAIN ON THE LEFT. USE OPPOSITE HOLES FOR HIGH ON RIGHT AND LOW ON LEFT.
- 5. TO CHANGE FOUNTAIN MTG. SCREW LOCATIONS: FIRST REMOVE SCREWS AND THEN SQUEEZE CLIPS ON NUT RETAINER TO POP OUT. SNAP INTO NEW POSITIONS FROM BACKSIDE AND RE-ASSEMBLE SCREWS.
- 6. IMPORTANT: A L.H. LOW (OPTIONAL) CONFIGURATION WILL REQUIRE A DIFFERENT BACK PANEL AND THE WASTE AND SUPPLY DIMENSIONS SHOWN (*) MUST BE REVERSED.

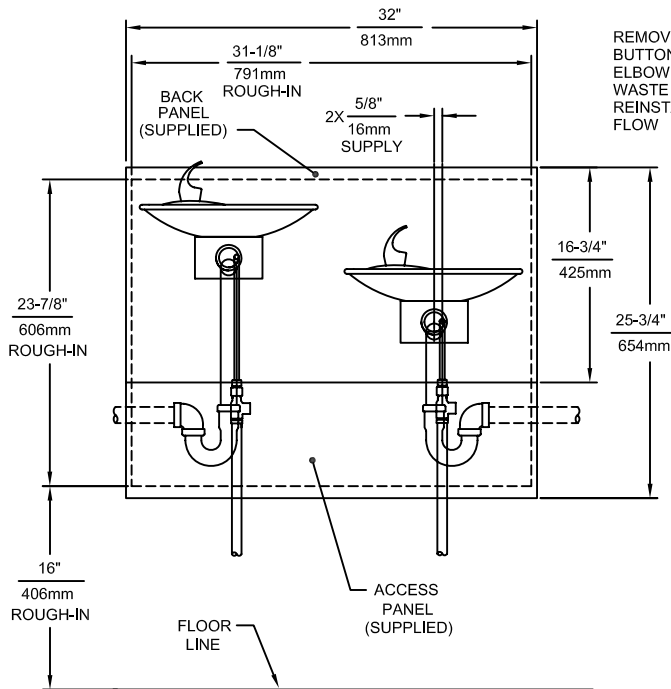

REMOVE VALVE FROM PUSH BUTTON TO INSTALL WASTE ELBOW ONTO BOWL. AFTER WASTE ELBOW IS INSTALLED, REINSTALL VALVE & ADJUST FLOW

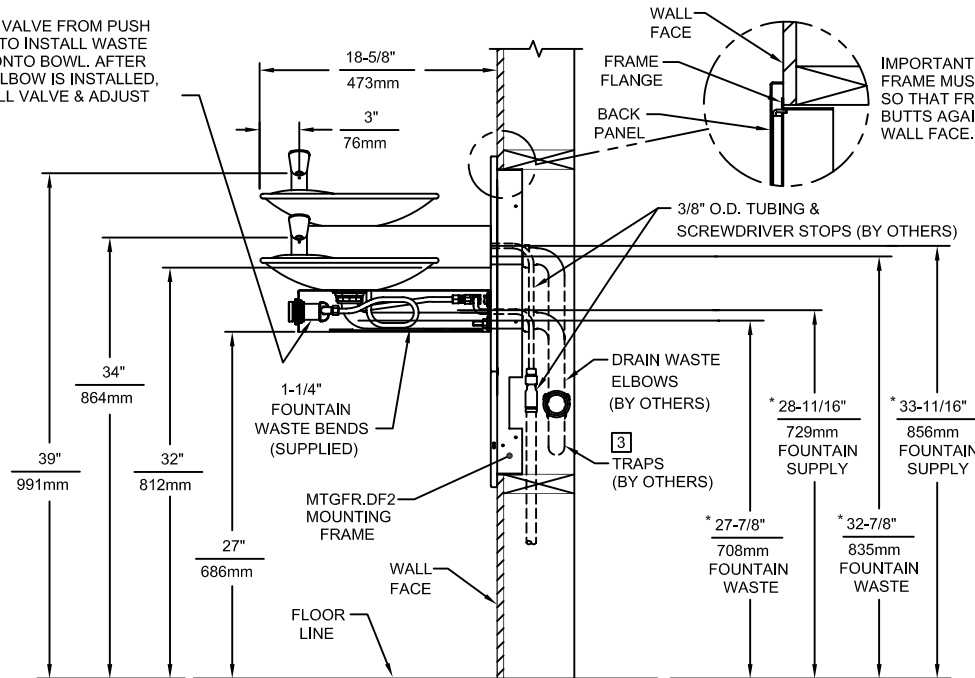

IMPORTANT: MOUNTING FRAME MUST BE INSTALLED SO THAT FRAME FLANGE BUTTS AGAINST FINISHED WALL FACE.

Haws Corporation
 INFO FAX : 1-888-FAX-HAWS (1-888-329-4297)
 1455 Kleppe Ln, Sparks NV, 89431
 Phone: 775-359-4712 Fax: 775-359-7424
 Haws Ag Bachweg 3 CH-3401 Burgdorf Switzerland
 Haws Mfg Pte Ltd 74 Sungei Kadut Loop Singapore 729531
 e-mail: Haws@hawsco.com website: www.hawsco.com

ECR NO.	REVISED PER (BY)	MODEL(S):	PART NUMBER:
PM	ECN: 3878 HIM	1011HPSMS/1011MS	002076519.D
DRAWN:	DATE:	INFO FAX DOC #:	DRAWING NUMBER:
PM	08/02/99	21011467/2101167	14219C00
APPROVED:	DATE:	SCALE: 1:15	DRAWING TYPE: INSTALLATION/FAXBACK
			SIZE: A SH: 1 OF 1