

FEATURES & BENEFITS

BUBBLER HEAD

Polished chrome-plated brass bubbler head features an integral basin shank for added strength, and is equipped with a shielded, anti-squirt orifice that provides a steady sanitary source of water.

INTEGRATED TRAP

Spacious fountain design allows for the trap to be internally mounted which allows for easy access, and aids and reduces the installation process.

CONSTRUCTION

18 gauge Type 304 Stainless Steel construction with vandal-resistant bottom plates provides a long lasting unit with added peace of mind.

QUALITY CONTROL

Fountain is pre-built and fully water and pressure tested to ensure no leaks and proper function for reduced installation time and added peace of mind.

PUSH BUTTON

With its patented (Pat. # 6,981,692) stainless steel, push-button activated valve assembly which allows for front access stream adjustment as well as cartridge and strainer access, this fountain offers 100% lead free waterways. The valve works at an operating pressure range of 30 to 90 psi (2.1 to 6.2 bar).



SPECIFICATIONS

Model 1105 wall mounted drinking fountain shall include an 18 gauge Type 304 Stainless Steel satin finish basin, push-button operated stainless steel valve with front accessible cartridge and flow adjustment, 100% lead-free waterways, polished chrome-plated brass vandal-resistant bubbler head, polished chrome-plated brass vandal-resistant waste strainer, vandal-resistant bottom plate, and 1-1/4" IPS trap.

OPTIONS

- Filter: Model 6426, 12" x 2" (30.5 x 5.1 cm), in-line lead removal element that reduces lead from incoming water supply.
- Mounting: Model 6700 universal mounting plate for most wall mounted fountains.
- Support Carrier: Model 6800 universal in-wall mounting support for use with most fountains.
- Back Panel: Model BP3, satin finish stainless steel back panel.

To see all options for this model, visit www.hawsco.com

APPLICATIONS

Perfect for either public or private indoor/outdoor settings, Model 1105 is a great fit in areas where aesthetics are important to the overall appeal of the architecture. This series is precisely mounted, making it a nice addition to any surrounding. Beautiful satin finish helps to maintain the fountains overall appeal so it always remains looking as new as it did when it was installed. Specifically, this type of wall mounted drinking fountain may be placed in settings such as: schools and other locations in and around office buildings where the temperature remains above freezing.

Haws manufactures drinking fountains and electric water coolers to be lead-free by all known definitions including NSF/ANSI Standard 61, Section 9, California Proposition 65, and the Federal Safe Drinking Water Act. Product is compliant to California Health and Safety Code 116875 (AB 1953-2006) as evaluated by CSA International.

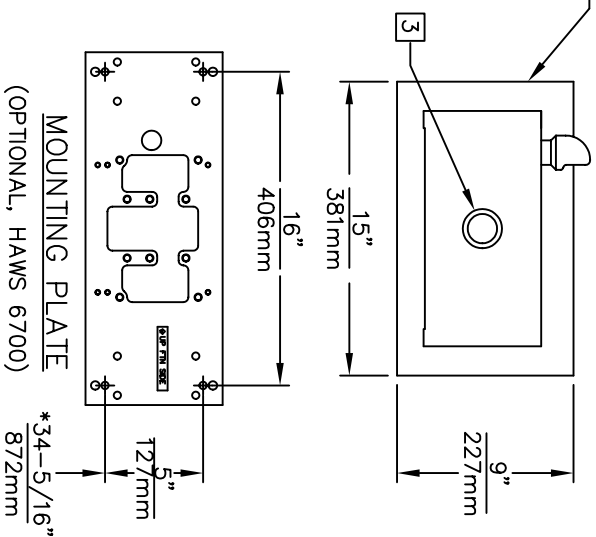
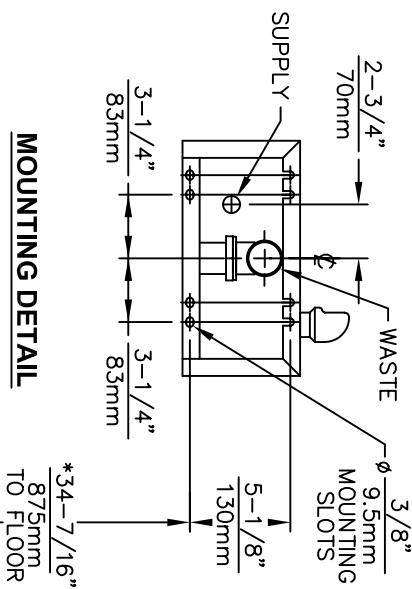
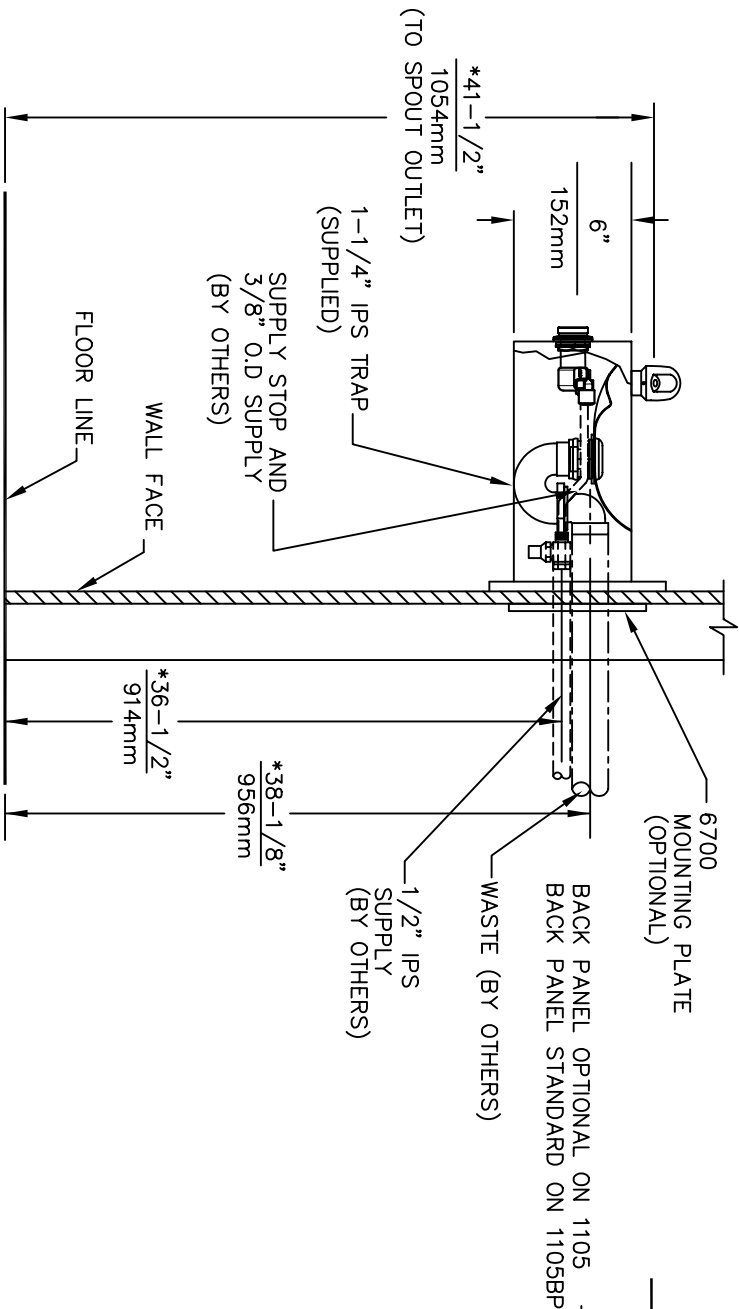
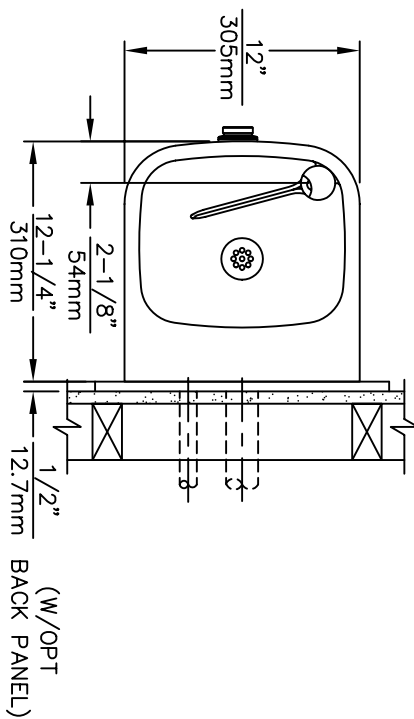

NOTES:

1. HOLD ROUGH-IN DIMENSIONS ± 1/4" (6.4mm).
2. WHEN INSTALLING THIS UNIT LOCAL, STATE OR FEDERAL CODES SHOULD BE ADHERED TO. FOR INSTALLATION HEIGHTS OTHER THAN SHOWN, DIMENSIONS MARKED (*) MUST BE ADJUSTED ACCORDINGLY.
3. REFER TO 5874SS/VRK5874 OPERATION AND MAINTENANCE MANUAL FOR PUSH BUTTON AND VALVE INSTALLATION/MAINTENANCE INSTRUCTIONS.

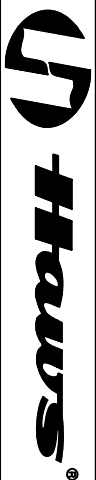

1455 KLEPPE LANE
SPARKS, NEVADA 89431
(775) 359-4712 FAX (756) 359-7424
E-MAIL: HAWS@HAWSOO.COM
WEBSITE: WWW.HAWSOO.COM

ECON. NO. REVISED PER BY:	MODEL(S)
DRAWN: ECON:4603	1105/1105BP
F. VASQUEZ 1/29/07	
DATE: CHK'D:	
APPROVER: DATE:	
SCALE: 1:1	DRAWING TYPE:
SIZE: A	SHEET: 1 OF 1
PART NUMBER	DRAWING NO.
0002076524.D	13527A00
REV	14