



model 1109.14

Wall-Mounted Drinking Fountain

FEATURES & BENEFITS

CONSTRUCTION

Heavy-duty 14 gauge Type 304 Stainless Steel construction with integral 1/4" (.6 cm) mounting plates for extra durability. Unit also includes vandal-resistant bottom plates for added peace-of-mind.

BUBBLER HEAD

Polished chrome-plated brass bubbler head features an integral basin shank for added strength, and is equipped with a shielded, anti-squirt orifice that provides a steady sanitary source of water.

INTEGRATED TRAP

Spacious fountain design allows for the trap to be internally mounted which allows for easy access, and aids and reduces the installation process.

QUALITY CONTROL

Fountain is pre-built and fully water and pressure tested to ensure no leaks and proper function for reduced installation time and added peace of mind.

PUSH BUTTON

With its patented (Pat. # 6,981,692) stainless steel, push-button activated valve assembly which allows for front access stream adjustment as well as cartridge and strainer access, this fountain offers 100% lead free waterways. The valve works at an operating pressure range of 30 to 90 psi (2.1 to 6.2 bar).



SPECIFICATIONS

Model 1109.14 is a wall mounted, barrier-free drinking fountain with 14 gauge Type 304 Stainless Steel with satin finish, push-button operated stainless steel valve with front accessible cartridge and flow adjustment, 100% lead-free waterways, polished chrome-plated brass bubbler head and waste strainer, integral 1/4" (.6 cm) stainless steel mounting plate, vandal-resistant bottom plate and 1-1/4" NPT trap.

OPTIONS

- Filter: Model 6426, 12" x 2" (30.5 x 5.1 cm), in-line lead removal element that reduces lead from incoming water supply.
- Mounting: Model 6700 universal mounting plate for most wall mounted fountains.
- Support Carrier: Model 6800 universal in-wall mounting support for use with most fountains.
- Back Panel: Model BP3, satin finish stainless steel back panel.

To see all options for this model, visit www.hawsc.com

APPLICATIONS

Perfect for either public or private indoor/outdoor settings, Model 1109.14 is a great fit in areas where aesthetics are important to the overall appeal of the architecture. Suitable in areas where extra durability is needed, thicker gauged steel is implemented so this unit mounts solidly from any wall. Beautiful satin finish helps to maintain the fountains overall appeal so it always remains looking as new as it did when it was installed. Specifically, this type of wall mounted drinking fountain may be placed in settings such as: schools and other locations in and around office buildings where the temperature remains above freezing.

Model meets all current Federal Regulations for the disabled including those in the Americans with Disabilities Act. Haws manufactures drinking fountains and electric water coolers to be lead-free by all known definitions including NSF/ANSI Standard 61, Section 9, California Proposition 65, and the Federal Safe Drinking Water Act. Product is compliant to California Health and Safety Code 116875 (AB 1953-2006).



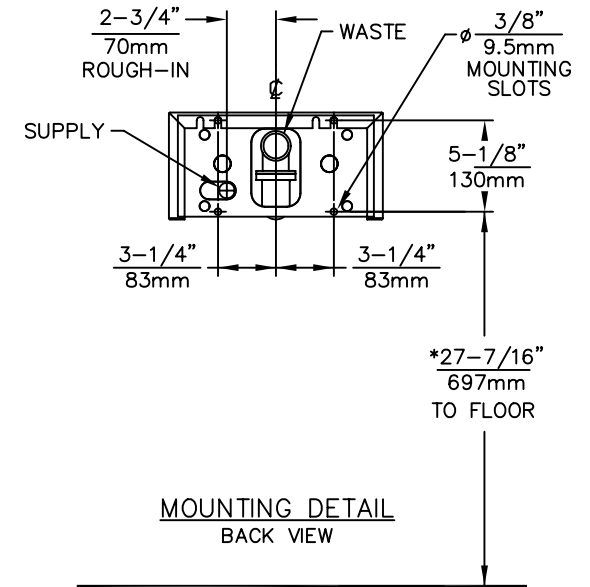
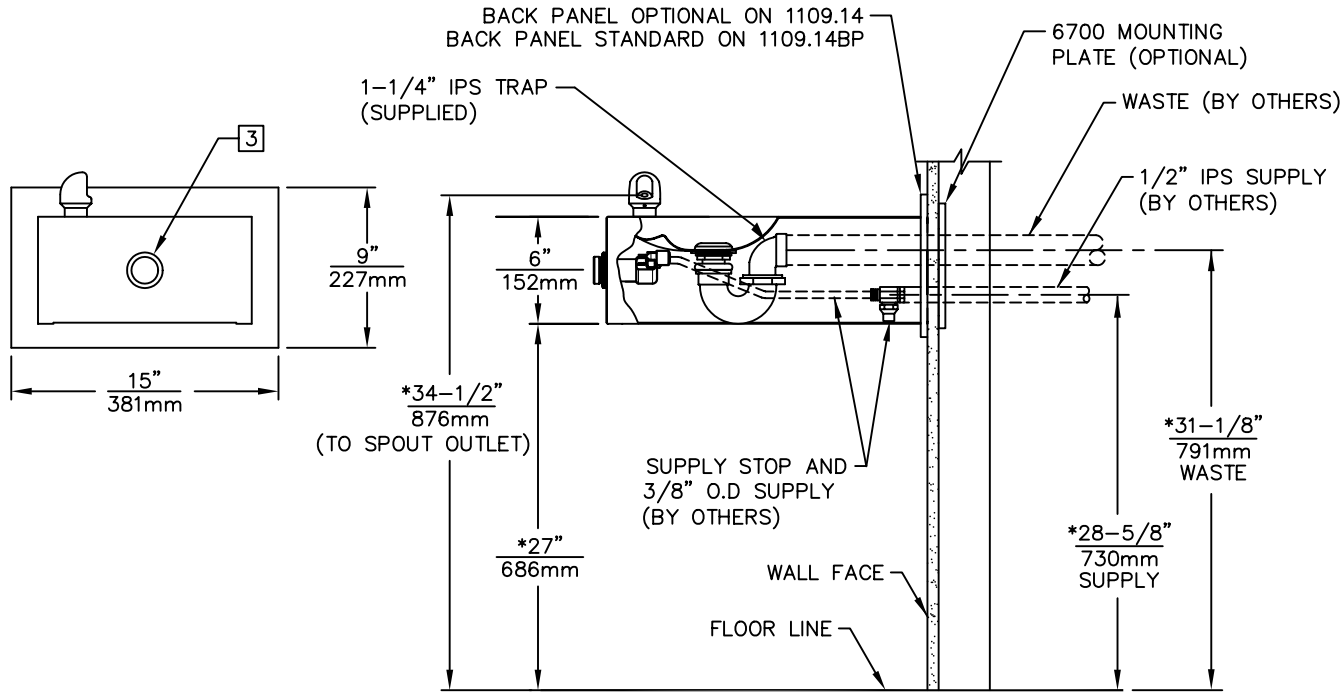
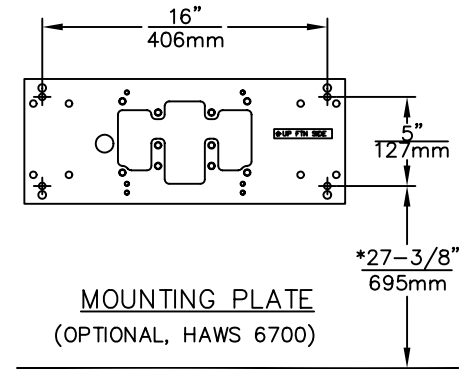
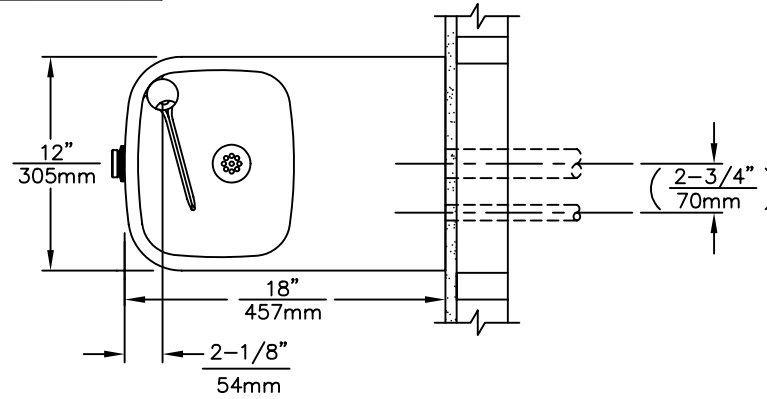

NOTES:

1. HOLD ROUGH-IN DIMENSIONS $\pm 1/4"$ (6.4mm).
2. WHEN INSTALLING THIS UNIT, LOCAL, STATE OR FEDERAL CODES SHOULD BE ADHERED TO. FOR INSTALLATION HEIGHTS OTHER THAN SHOWN, DIMENSIONS MARKED (*) MUST BE ADJUSTED ACCORDINGLY.
3. REFER TO 5874SS/VRK5874 OPERATION AND MAINTENANCE MANUAL FOR PUSH BUTTON AND VALVE INSTALLATION/MAINTENANCE INSTRUCTONS.

			1455 KLEPPE LANE SPARKS, NEVADA 89431 (775) 359-4712 FAX (775) 359-7424 E-MAIL: HAWS@HAWS.CO.COM WEBSITE: WWW.HAWS.CO.COM	
			ECN NO. REVISED PER BY: MODEL(S) ECN: 4603 HM 1109.14/1109.14BP	PART NUMBER 0002076625.D
DRAWN: F. VASQUEZ APPROVED:	DATE: 06/98 CHKD.:	DATE:	DRAWING NO. REV 13542C00 13	SCALE: 1:1 DRAWING TYPE: INSTALLATION SIZE: A SHEET 1 OF 1