

FEATURES & BENEFITS

INTEGRATED TRAP

All cast brass 1-1/4" NPT adjustable traps completely concealed inside bottom plates for easy installation and lack of unwanted access.

BARRIER-FREE CONFIGURABLE

Supplied with a low profile bowl, individual adjustable panels, and multiple mounting positions, this fountain can be configured for adult and child ADA considerations.

BUBBLER HEADS

Polished chrome-plated brass bubbler heads with integral 11/16" dia. basin shank and stainless anti-rotation roll pin for vandal resistance strength. Shielded, angled stream opening provides a steady, sanitary source of drinking water at .45 gpm.

DRINKING FOUNTAIN VALVES

Fountain incorporates touchless sensor operated stainless steel solenoid valves controlled by a transformer for handsfree operation. A pressure regulator is used to adjust the bubbler flow according to incoming water pressures.

VANDAL RESISTANT

The bubbler heads, drain strainers and bottom plates are locked in place, discouraging unwanted vandal tampering.

TAMPER RESISTANT

30-second obstruction time-out to reduce tampering of sensor.

CONSTRUCTION

One-piece drinking fountains with low-profile design made of 14 gauge Type 304 stainless steel with 1/4" (.6 cm) thick stainless back plates welded in, and vandal-resistant stainless bottom plates. Satin finish resists stains and corrosion.



SPECIFICATIONS

Model 1117LH02 low profile vandal-resistant ADA wall mounted adjustable motion activated drinking fountain shall include dual 14-gauge Type 304 Stainless Steel satin finish basins with integral 1/4" (.6 cm) thick stainless-steel back plates, touchless sensor operated solenoid valves with 30-second obstruction time-out, 100% lead free waterways, polished chrome-plated brass vandal-resistant bubbler heads, polished chrome-plated brass vandal-resistant waste strainers, vandal-resistant bottom plates, stainless steel satin finish back panel, adjustable mounting allowing either basin high or low, in-wall mounting plate, and 1-1/4" NPT concealed all cast-brass traps. The patented design allows the unit to be mounted to meet ADA or Child ADA specifications.

REQUIRES MODEL 6717 PRICED SEPARATELY.

FOR INDOOR USE ONLY

OPTIONS

- Remote Drinking Fountain Water chiller: Model HCR8, 8 gph (30.3 L) remote water chiller provides instantaneous cooling to meet a continuous demand for chilled water.
- Bottle Filler: Model 1920HO, bottle filler can be a stand-alone station, or mounted above Haws 1117L series drinking fountain models.
- Bottle Filler Stand: Model BTL1107, add-on stainless steel stand to place bottle on when 1920 bottle filler is used.
- Custom Logo Panel: Model 6475, Hydration By Haws™ logo panel with customization options.

For more information, visit www.hawsc.com or call (888) 640-4297.

APPLICATIONS

Perfect for either public or private indoor settings, Model 1117LH02 is a great fit in areas where aesthetics are important to the overall appeal of the architecture. Beautiful satin finish helps to maintain the fountains overall appeal. Specifically, this type of wall mounted drinking fountain may be placed in settings such as: schools and other locations in and around office buildings. Model meets all current Federal Regulations for the disabled including those in the Americans with Disabilities Act. Haws manufactures drinking fountains, faucets and electric water coolers to be lead-free by all known definitions including NSF/ANSI/CAN 61- Section 9, NSF/ANSI/CAN 372, California Proposition 65, and the Federal Safe Drinking Water Act. Product is compliant to California Health and Safety Code 116875 (AB 1953-2006), and NSF/ANSI/CAN 61: Q ≤ 1.



NOTES:

1. HOLD ROUGH-IN DIMENSIONS $\pm 1/8"$ (3.2MM).
2. WHEN INSTALLING THIS UNIT, LOCAL, STATE, OR FEDERAL CODES SHOULD BE ADHERED TO. FOR INSTALLATION HEIGHTS OTHER THAN SHOWN, DIMENSIONS MARKED (*) MUST BE ADJUSTED ACCORDINGLY.
3. REFER TO 5674 SERIES OPERATION AND MAINTENANCE MANUAL FOR PUSH BUTTON AND VALVE INSTALLATION/MAINTENANCE INSTRUCTIONS.
4. ROUGH IN DIMENSIONS FOR FOUNTAIN HEIGHTS:

CHILD WHEELCHAIR HEIGHT: SEE SHT 3 FIG 1

WASTE: 26-1/4" (667mm)
 SUPPLY: 26-1/8" (664mm)
 MOUNTING HOLE: 24-13/16" (630mm)
 FOUNTAIN: 24" (610mm)
 BUBBLER: 29-7/8" (759mm)

ADULT WHEELCHAIR HEIGHT: SEE SHT 3 FIG 2

WASTE: 29-1/4" (743mm)
 SUPPLY: 29-1/8" (740mm)
 MOUNTING HOLE: 27-13/16" (709mm)
 FOUNTAIN: 27" (686mm)
 BUBBLER: 32-7/8" (832mm)

STANDING ADULT HEIGHT: SEE SHT 3 FIG 3

WASTE: 34-3/4" (883mm)
 SUPPLY: 34-3/8" (879mm)
 MOUNTING HOLE: 33-5/16" (846mm)
 FOUNTAIN: 32-1/5" (826mm)
 BUBBLER: 38-3/8" (972mm)

5. REFER TO MODEL 1117LHO INSTALLATION DRAWING SHEET 3 OF 3 (ON HAWS WEBSITE WWW.HAWS.CO.COM) FOR PERMISSIBLE BOWL MOUNTING PATTERNS. TWO WHEELCHAIR HEIGHT FOUNTAINS CANNOT BE MOUNTED SIDE BY SIDE PER ANSI A117.1.
6. REFER TO 1RKH0 OR 2RKH0 SERIES OPERATION INSTRUCTIONS FOR TRANSFORMER AND SENSOR SETUP.
7. MAXIMUM ADJUSTABLE RANGE IS 15" FROM PARALLEL TO BACK WALL.

NOTES CONTINUED ON SHEET 3 OF 3

3/8" O.D. SUPPLY TUBING IS SUPPLIED. SCREWDRIVER STOP (NOT SHOWN) IS NOT SUPPLIED.

3/8" O.D. SUPPLY LINE TO TEE

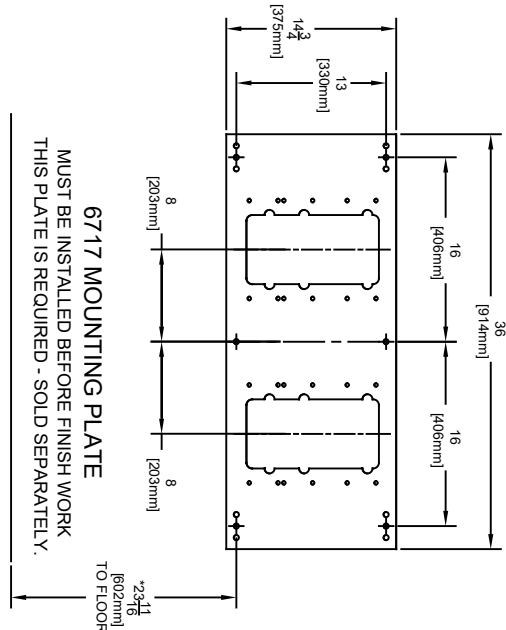

6717 MOUNTING PLATE
 MUST BE INSTALLED BEFORE FINISH WORK
 THIS PLATE IS REQUIRED - SOLD SEPARATELY.

FROM SUPPLY
 Y-STRAINER
 SOLENOID VALVE
 PRESSURE REGULATOR
 TO BUBBLER HEAD

TO PUSH BUTTON
 FOUNTAIN VALVE
 WHITE WIRE
 TRANSFORMER AC(N) (+VDC)
 BLACK WIRE
 SENSOR
 TO BUBBLER HEAD

SENSOR WIRING / SUPPLY
 PLUMBING SCHEMATIC

MODEL(S)
 1117LHO/1117LHO2

1456 KLEPPE LANE
 SPARKS, NEVADA 89431
 (775) 359-4712 FAX (775) 359-7424
 E-MAIL: HAWS@HAWS.CO.COM
 WEBSITE: WWW.HAWS.CO.COM

PART NUMBER
 0510001209.D
 REVISION
 1

APPROVED: FV DATE: 07/21/21
 SCALE: 1:2 DRAWING TYPE: INSTALLATION
 SHEET 1 OF 3

©2021 Haws Corporation - All Rights Reserved. HAWS® and other trademarks used in these materials are the exclusive property of Haws Corporation.

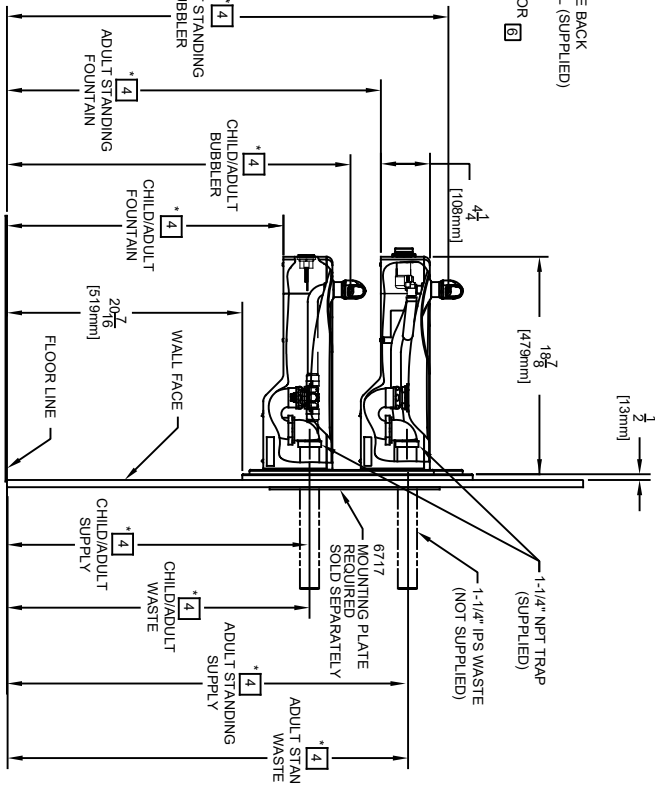
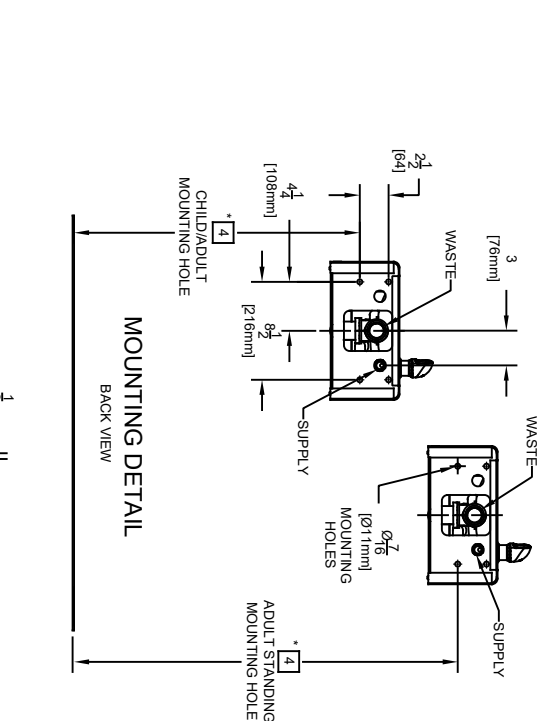
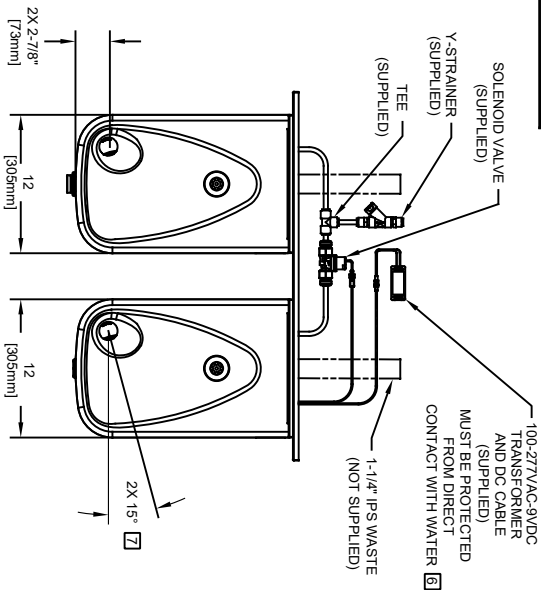

MODEL 1117LHO SHOWN
 MODEL 1117LHO2 ON SHEET 2
 (ROUGH-IN DIMENSIONS APPLY TO BOTH MODELS)

6717 MOUNTING PLATE
 REQUIRED
 SOLD SEPARATELY

©2021 Haws Corporation - All Rights Reserved. HAWS® and other trademarks used in these materials are the exclusive property of Haws Corporation.

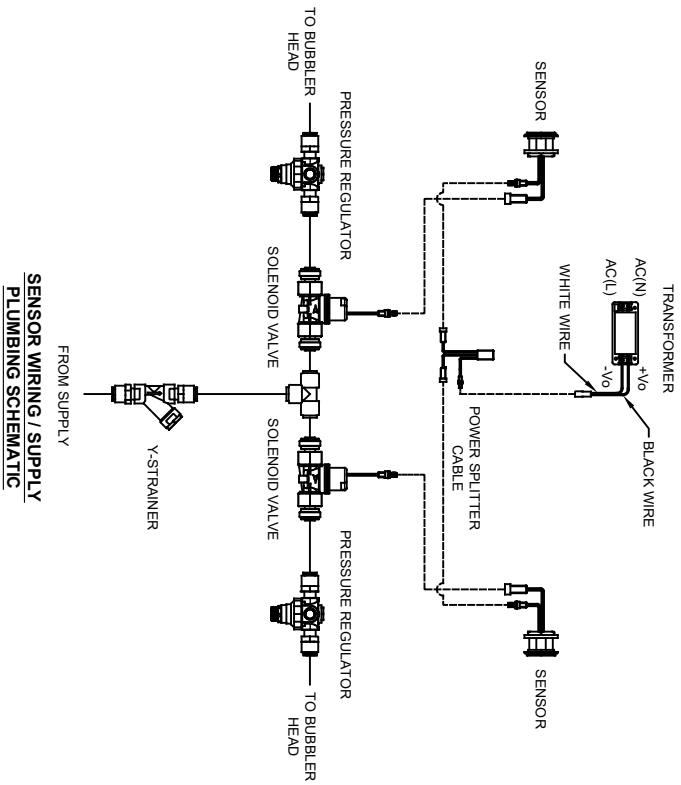
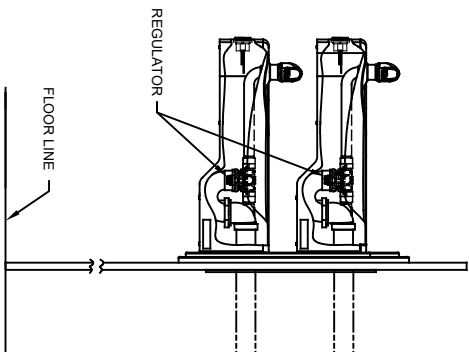
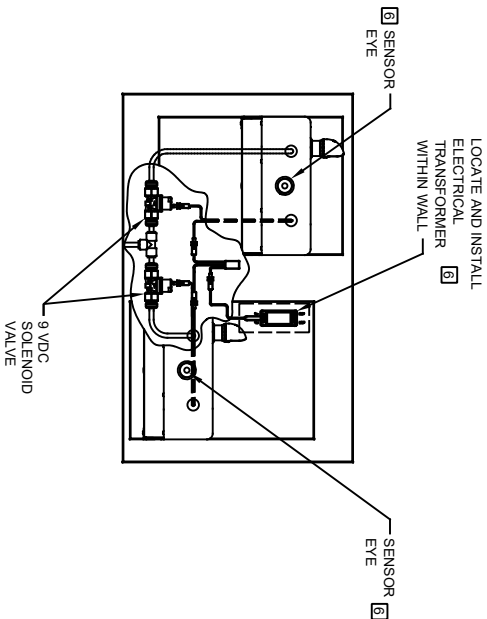
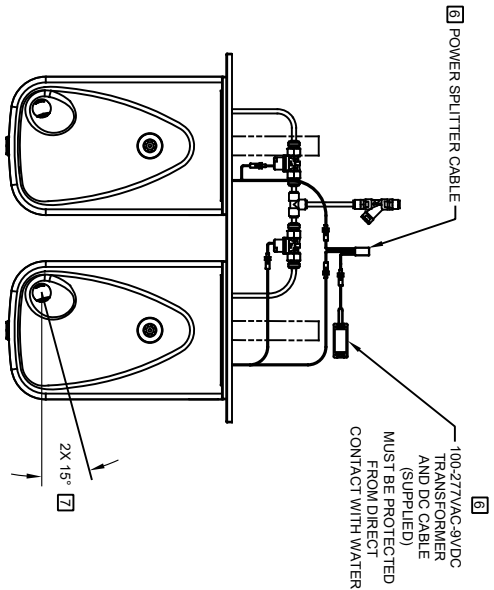

MODEL 1117LHO2 SHOWN
MODEL 1117LHO ON SHEET 1
(SEE SHEET 1 FOR APPLICABLE ROUGH-IN DIMENSIONS)

Haws

1459 KLEPPE LANE
SPARKS, NEVADA, 89431
(775) 359-4712 FAX (775) 359-7424
E-MAIL: HAWS@HAWSCO.COM
WEBSITE: WWW.HAWSCO.COM

ECN NO. REVISED PER BY: MODEL(S)
5712 ECN: 5712 FV: 1117LHO/1117LHO2

DATE: 07/21/21
CHKD: DP

APPROVED: FV: SCALE: 1/2 DRAWING TYPE: INSTALLATION SIZE: A SHEET 2 OF 3

PART NUMBER: 0510001209.D
REVISION: 1

NOTES:

- 8 FIGURES 1 AND 2 ARE REVERSIBLE. CAN BE RIGHT OR LEFT SIDE HIGH.
- 9 USE SHADED HOLES TO MOUNT AT INDICATED POSITIONS BASED ON COMBINATION SELECTED (FIGS. 1 THRU 3).
- 10. REFER TO SHEET 1 OF 3, NOTE 4, FOR INSTALLED FOUNTAIN DIMENSIONS.

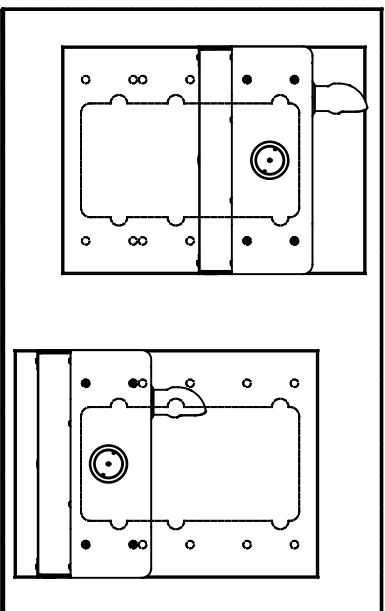

FIGURE 1.

ADULT STANDING/CHILD WHEELCHAIR

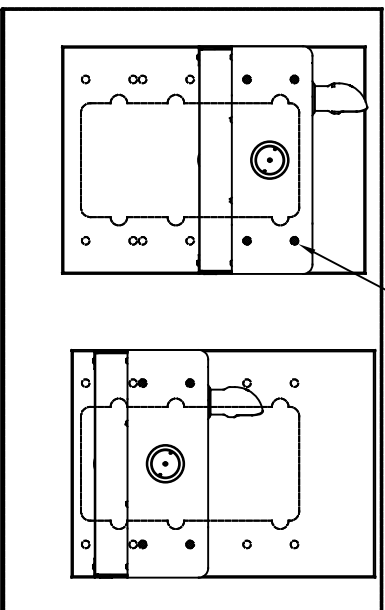

FIGURE 2.

ADULT STANDING/ADULT WHEELCHAIR

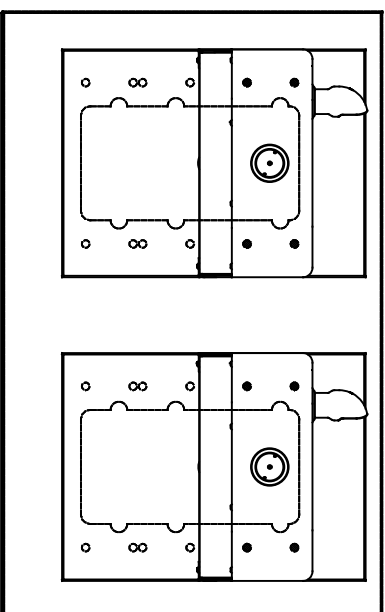

FIGURE 3.

ADULT STANDING/ADULT STANDING

BOWL MOUNTING PATTERNS

		Haws		1456 KLEPPE LANE SPARKS, NEVADA 89431 (775) 359-4712 FAX (775) 359-7424 E-MAIL: HAWS@HAWSCO.COM WEBSITE: WWW.HAWSCO.COM	
ECN NO. REVISED PER BY:	MODEL(S)	PART NUMBER			
5712 FV	1117LHO/1117LHO2	0510001209.D			
DATE: 07/21/21	SCALE: 1:2	DRAWING TYPE:	INSTALLATION:	SIZE: A	SHEET 3 OF 3
CHKD: DP	REVISION: 1				
APPROVED: FV	DATE: 07/29/21				