

## FEATURES & BENEFITS

### CONSTRUCTION

Unit is made of 14 gauge Type 304 stainless steel with a satin finish that resists stains and corrosion, and has soft, rounded corners. Unit features stainless steel satin finish back panel, vandal-resistant bottom plate, and 1-1/4" integral trap.

### BUBBLER HEADS

Polished chrome-plated brass bubbler heads with integral 11/16" dia. basin shank and stainless anti-rotation roll pin for vandal resistance strength. Shielded, angled stream opening provides a steady, sanitary source of drinking water at .45 gpm.

### DRINKING FOUNTAIN VALVES

Fountain incorporates touchless sensor operated stainless steel solenoid valves controlled by a transformer for hands-free operation. A pressure regulator is used to adjust the bubbler flow according to incoming water pressures.

### VANDAL RESISTANT

The bubbler heads, drain strainers and bottom plates are locked in place, discouraging unwanted vandal tampering.

### TAMPER RESISTANT

30-second obstruction time-out to reduce tampering of sensor.

### INTEGRATED TRAP

All cast brass 1-1/4" NPT adjustable traps completely concealed inside bottom plates for easy installation and lack of unwanted access.



## SPECIFICATIONS

Model 1119.14H02 ADA vandal-resistant wall mounted motion-activated drinking fountain shall include dual 14 gauge Type 304 Stainless Steel satin finish basins, touchless sensor operated solenoid valves with 30-second obstruction time-out, 100% lead-free waterways, polished chrome-plated brass vandal-resistant bubbler heads, polished chrome-plated brass vandal-resistant waste strainers, vandal-resistant bottom plates, stainless steel satin finish back panel, high and low fountain mounting levels, and 1-1/4" NPT traps.

### FOR INDOOR USE ONLY

## OPTIONS

- Mounting Plate: Model 6700.4, in-wall mounting plate which is 36" wide by 3/16" thick solid steel that spans three studs for a heavy-duty vandal-resistant rigid installation.
- Support Frame: Model 6800 In-wall floor mounted fixture support legs, welded steel 4-bolt floor flanges, and supplied with 'U' bolts and hardware.
- Bottle Filler: Model 1920HO, bottle filler can be a stand-alone station, or mounted above Haws 1119 series drinking fountain models.

For more information, visit [www.hawsc.com](http://www.hawsc.com) or call (888) 640-4297.

## APPLICATIONS

Perfect for either public or private indoor/outdoor settings, Model 1119.14H02 is a great fit in are as where aesthetics are important to the over all appeal of the architecture. This series is precisely mounted, making it a nice addition to any surrounding. Beautiful satin finish helps to maintain the fountains overall appeal so it always remains looking as new as it did when it was installed. Specifically, this type of wall mounted drinking fountain may be placed in settings such as: schools and other locations in and around office buildings where the temperature remains above freezing. Model meets all current Federal Regulations for the disabled including those in the Americans with Disabilities Act. Haws manufactures drinking fountains, faucets and electric water coolers to be lead-free by all known definitions including NSF/ANSI/CAN 61- Section 9, NSF/ANSI/CAN 372, California Proposition 65, and the Federal Safe Drinking Water Act. Product is compliant to California Health and Safety Code 116875 (AB 1953-2006), and NSF/ANSI/CAN 61: Q ≤ 1.



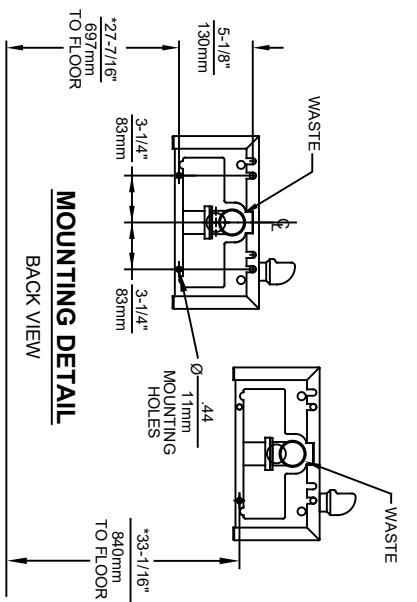
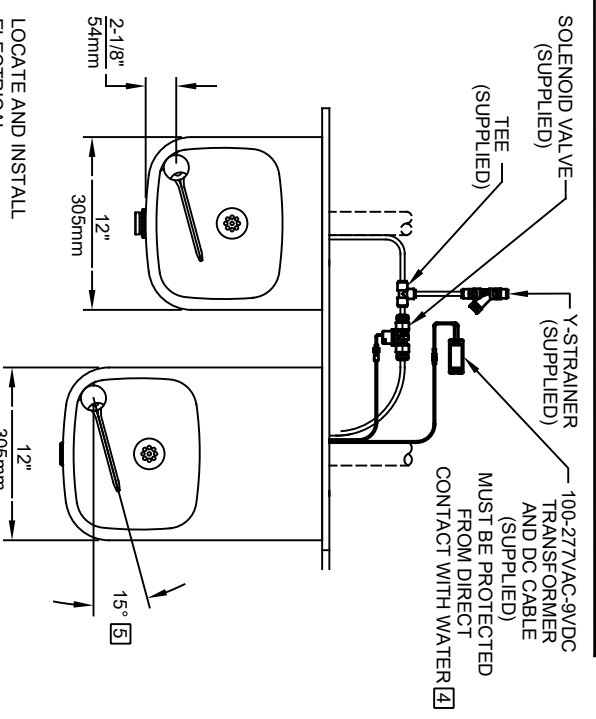

- NOTES:**
1. HOLD ROUGH-IN DIMENSIONS ± 1/4" (6.4mm).
  2. WHEN INSTALLING THIS UNIT, LOCAL, STATE, OR FEDERAL CODES SHOULD BE ADHERED TO. FOR INSTALLATION HEIGHTS OTHER THAN SHOWN, DIMENSIONS MARKED (\*) MUST BE ADJUSTED ACCORDINGLY.
  3. REFER TO 5874 SERIES/VRK5874 OPERATION AND MAINTENANCE MANUAL FOR PUSH BUTTON AND VALVE INSTALLATION AND MAINTENANCE INSTRUCTIONS.
  4. REFER TO 1RKH0 OR 2RKH0 SERIES OPERATION INSTRUCTIONS FOR TRANSFORMER AND SENSOR SETUP.
  5. MAXIMUM ADJUSTABLE RANGE IS 15° FROM PARALLEL TO BACK OF WALL.

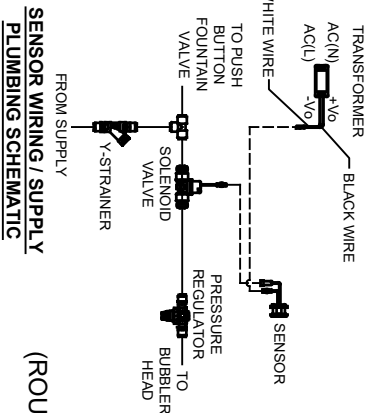
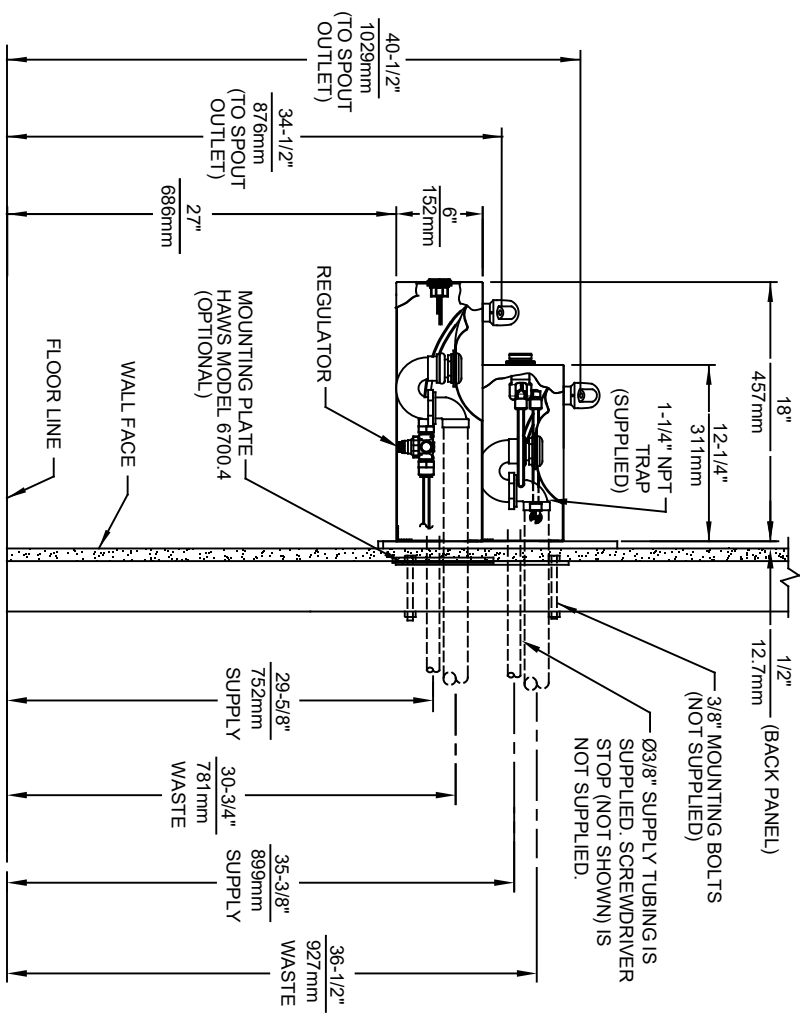
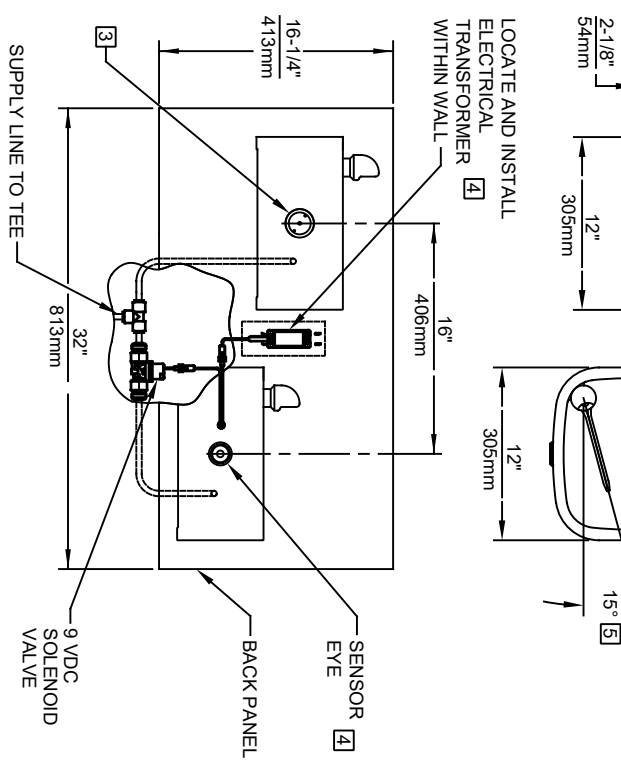

MODEL 1119, 14HO SHOWN  
 MODEL 1119, 14HO2 ON SHEET 2  
 (ROUGH-IN DIMENSIONS APPLY TO BOTH MODELS)

**1456 KLEPPE LANE**  
 SPARKS, NEVADA 89431  
 (775) 359-4712 FAX (775) 359-7424  
 E-MAIL: HAWS@HAWS.CO.COM  
 WEBSITE: WWW.HAWS.CO.COM

ECN NO. REVISED PER/BY:	MODEL(S)	PART NUMBER	DRAWING TYPE
5893	1119, 14HO/1119, 14HO2	0510001203.D	INSTALLATION
DATE: 05/10/21	DATE: 11/22/21	REVISION: 2	SCALE: 1:14
DP: 11/1/21	SCALE: 1:14	SHEET: 1 OF 2	DATE: 11/22/21

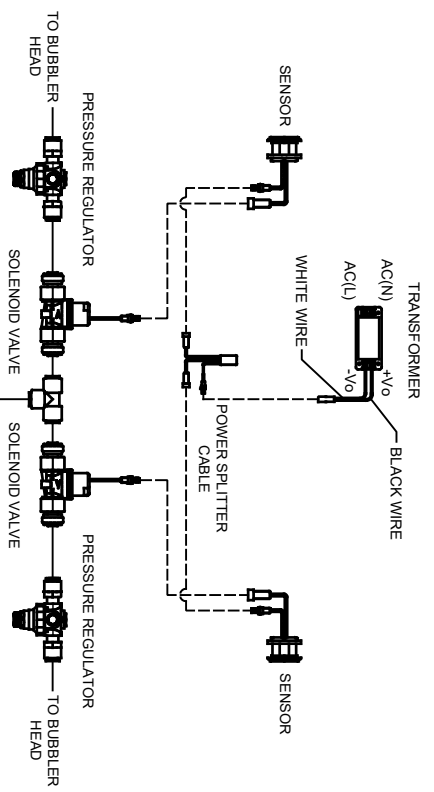
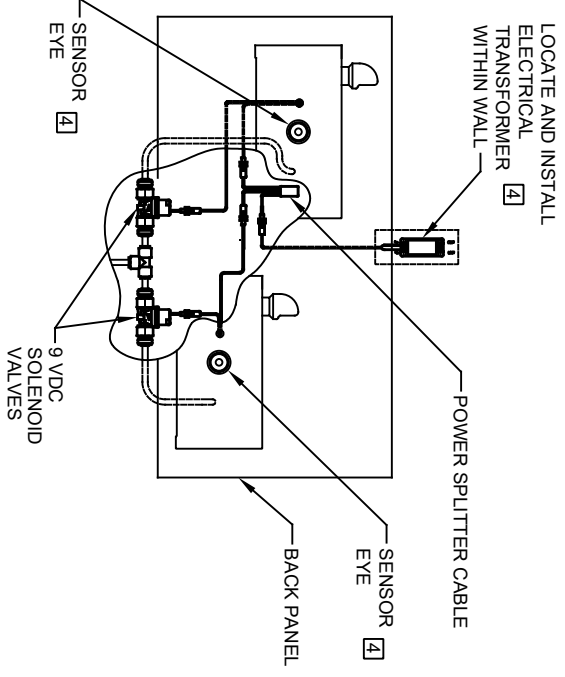
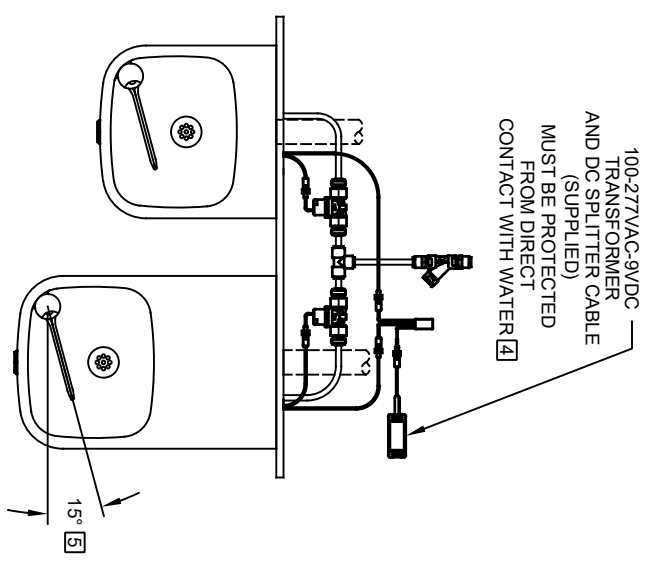

**SENSOR WIRING / SUPPLY PLUMBING SCHEMATIC**

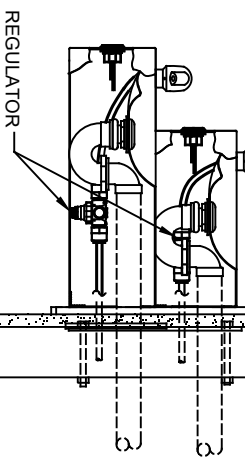
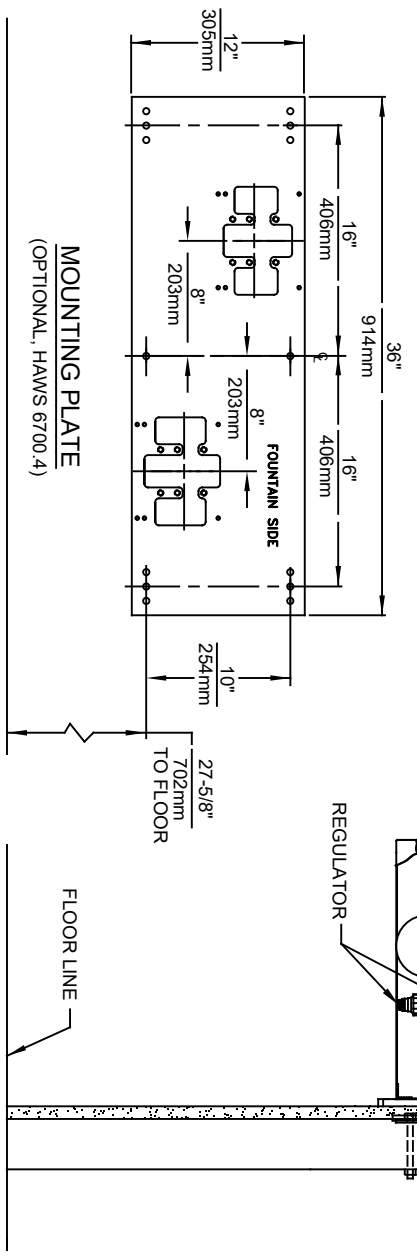

MODEL 1119.14HO2 SHOWN  
 MODEL 1119.14HO ON SHEET 1  
 (SEE SHEET 1 FOR APPLICABLE ROUGH-IN DIMENSIONS)

		<b>MODEL(S)</b>	
1459 KLEPPE LANE SPARKS, NEVADA 89431 (775) 359-4712 FAX (775) 359-7424 E-MAIL: HAWS@HAWS.CO.COM WEBSITE: WWW.HAWS.CO.COM		1119.14HO/1119.14HO2	
ECN NO. REVISED PER BY: 5893 EON: 5741 FV	DATE: 05/10/21 CHKD: BMW	PART NUMBER	REVISION
APPROVED: FV	DATE: 11/1/21	0510001203.D	2
SCALE: 1:14	DRAWING TYPE: INSTALLATION	SHEET: 2	OF: 2