



model 1119HO2

Wall Mount ADA Touchless Dual Fountain

FEATURES & BENEFITS

CONSTRUCTION

Unit is made of 18 gauge Type 304 stainless steel with a satin finish that resists stains and corrosion, and has soft, rounded corners. Unit features stainless steel satin finish back panel, vandal-resistant bottom plate, and 1-1/4" integral trap.

INTEGRATED TRAP

All cast brass 1-1/4" NPT adjustable traps completely concealed inside bottom plates for easy installation and lack of unwanted access.

HANDS OFF

Touchless operation for safety and peace of mind

BUBBLER HEAD

Polished chrome-plated brass bubbler heads with integral basin shank for added strength. Shielded, angled stream opening provides a steady, sanitary source of drinking water at .45 gpm.

DRINKING FOUNTAIN VALVE

Fountain incorporates touchless sensor operated stainless steel solenoid valves controlled by a transformer for handsfree operation. A pressure regulator is used to adjust the bubbler flow according to incoming water pressures.

CUSTOM LOGO PANEL

Personalize your new or existing fountain or bottle filler where space permits with an optional customizable 10" high by 4.25" wide stainless steel panel. Virtually any company logo, event logo or graphic can be placed on this panel. Mounted with strong, moisture-resistant adhesive backing.



SPECIFICATIONS

Model 1119HO2 Hi-Lo ADA wall mounted touchless drinking fountain shall include dual 18 gauge Type 304 Stainless Steel satin finish basins, touchless sensor operated solenoid valves controlled by a transformer, 100% lead-free waterways, polished chrome-plated brass vandal-resistant bubbler heads, polished chrome-plated brass vandal-resistant waste strainers, vandal-resistant bottom plates, stainless steel satin finish back panel, high and low fountain mounting levels, and 1-1/4" NPT traps.

APPLICATIONS

Perfect for either public or private indoor/outdoor settings, Model 1119HO2 is a great fit in areas where aesthetics are important to the overall appeal of the architecture. This series is precisely mounted, making it a nice addition to any surrounding. Beautiful satin finish helps to maintain the fountains overall appeal so it always remains looking as new as it did when it was installed. Specifically, this type of wall mounted drinking fountain may be placed in settings such as: schools and other locations in and around office buildings where the temperature remains above freezing. Model meets all current Federal Regulations for the disabled including those in the Americans with Disabilities Act. Haws manufactures drinking fountains and electric water coolers to be lead-free by all known definitions including NSF/ANSI Standard 61, Section 9, NSF/ANSI 372, California Proposition 65, and the Federal Safe Drinking Water Act. Product is compliant to California Health and Safety Code 116875 (AB 1953-2006).

OPTIONS

- ❑ Cane Detection, Floor Mounted: Model SK6, floor mounted cane detection for the Haws Hi-Lo drinking fountains.
- ❑ Custom Logo Panel: Model 6475, Hydration By Haws™ logo panel with customization options.
- ❑ Remote Drinking Fountain Water chiller: Model HCR8, 8 gph (30.3 L) remote water chiller provides instantaneous cooling to meet a continuous demand for chilled water.
- ❑ Bottle Filler: Model 1920HO, bottle filler can be a stand-alone station, or mounted above Haws 1001, 1011, 1107L, 1109, 1117L, and 1119 series drinking fountain models.

For more information, visit www.hawsco.com or call (888) 640-4297.



AVAILABLE WITH HANDS OFF SENSOR
IN LIEU OF PUSH BUTTON

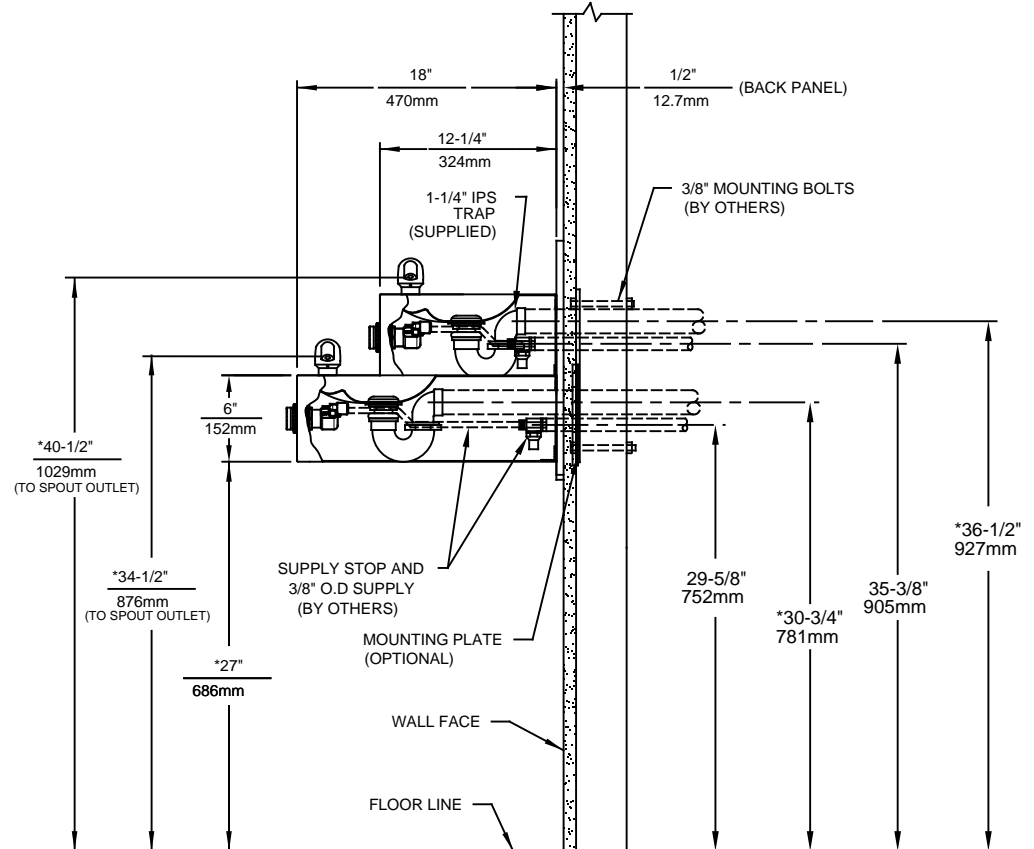
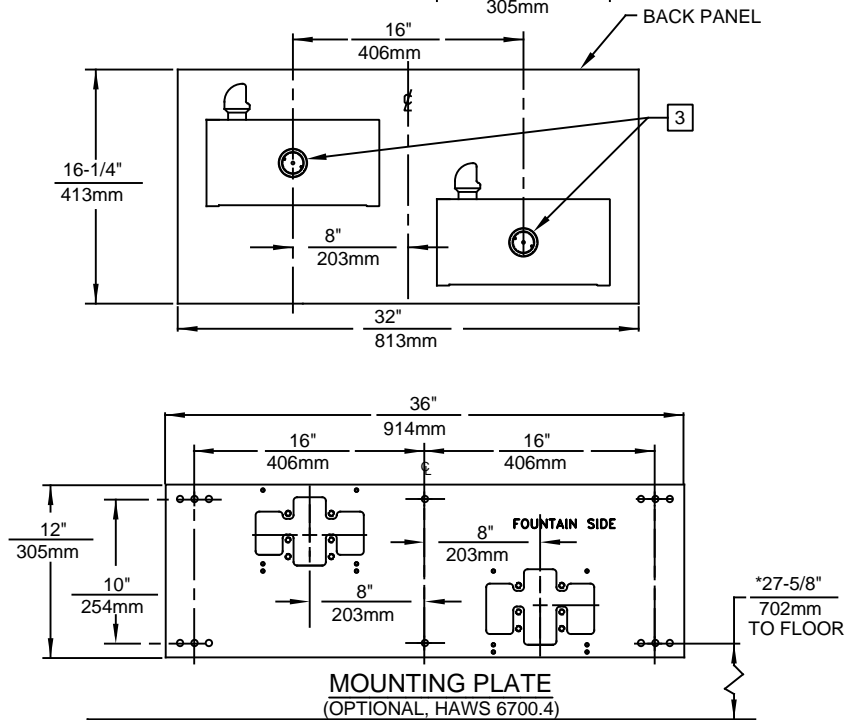
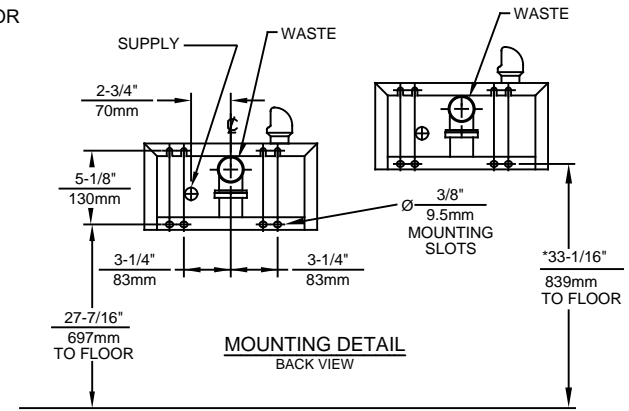
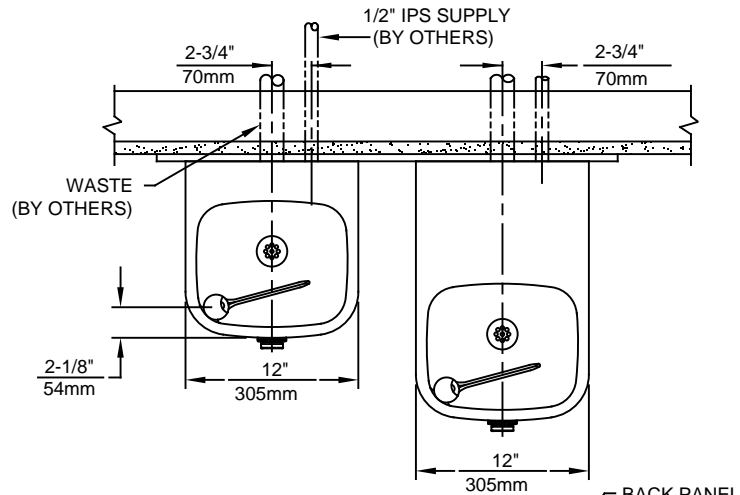

NOTES:

1. HOLD ROUGH-IN DIMENSIONS $\pm 1/4"$ (6.4mm).
2. WHEN INSTALLING THIS UNIT, LOCAL, STATE, OR FEDERAL CODES SHOULD BE ADHERED TO. FOR INSTALLATION HEIGHTS OTHER THAN SHOWN, DIMENSIONS MARKED (*) MUST BE ADJUSTED ACCORDINGLY.
- 3 REFER TO 5874 SERIES/VRK5874 OPERATION AND MAINTENANCE MANUAL FOR PUSH BUTTON AND VALVE INSTALLATION/MAINTENANCE INSTRUCTIONS.

1455 KLEPPE LANE
SPARKS, NEVADA 89431
(775) 359-4712 FAX (775) 359-7424
E-MAIL: HAWS@HAWSCO.COM
WEBSITE: WWW.HAWSCO.COM

ECN NO. REVISED PER BY:	DATE: 04/15/98	CHKD.: GC	MODEL(S)
DRAWN: F.VASQUEZ	DATE: 11/23/17	APPROVED: FV	1119/1119HO2
SCALE: 1:14			DRAWING TYPE: INSTALLATION
SIZE: A			SHEET 1 OF 1
PART NUMBER			0002076716.D
REVISION			19