

## FEATURES & BENEFITS

### SMART ENERGY SAVINGS MODE

Energy saving feature allows unit to power off the refrigeration system after 2 hours of non-use and dark ambient light conditions. Unit will automatically start back up next time unit is used or lights are turned back on.

### FRESH FILTERED WATER

Always fresh filtered water, 3000-gallon (11,356 L) capacity, Electronic Life Cycle Control filter cartridge will shut off water flow when capacity is reached. To ensure fresh filtered water, flow will only start again when filter is changed. Filter status colored indicator lights located under bowl.

### MODERN INNOVATIVE DESIGN

Modern, innovative design with stainless steel finish gives a sleek look and feel to high-end architectural spaces and lobbies.

### UNIVERSAL MOUNTING

Specially designed internal configuration allows for mounting over existing competitors rough-ins.

### BUBBLER HEAD

Bubbler features a flexible antimicrobial mouth guard to protect against injury and microorganisms. Anti-rotational design prevents unwanted attempts to remove or rotate the head.

### VANDAL RESISTANT FEATURES

Exceptional vandal resistance features include a hidden programming button, anti-rotational bubbler head with an optional stainless steel version, UPC impact tested bowl supports, Torx bit access screws, steel frame, and fasteners hidden from public view.

### ACTIVATION

Electronic front push bar eight inches wide and operable from any point on the surface activates an electronic solenoid valve.

### BUBBLER DEACTIVATION

This feature gives sites the flexibility to temporarily deactivate the flow to the drinking fountain bubbler head.

## OPTIONS

- 12 Pack Filter Cartridges for Haws Water Cooler: Model 6428-C, pack of twelve 3000-gallon (11356 L) replacement filters with Electronic Lifecycle Control for Haws 1200 series water coolers.
- Bubbler Head: Model 5716, stainless steel bubbler head for the Haws 1200 series water coolers.

For more information, visit [www.hawsc.com](http://www.hawsc.com) or call (888) 640-4297.



## SPECIFICATIONS

Model 1201SF indoor wall-mount ADA stainless steel filtered water cooler shall include an ASHRAE compliant, hermetically sealed R-134a refrigeration system with thermostat. Unit features a unique, modern design with 304 satin finish stainless steel outer shell. Energy savings feature powers down refrigeration system after 2 hours of non-use and the lights shut off, and will automatically start again when used. The 3000-gallon (11,356 L) filter with Electronic Lifecycle Control turns water off when capacity is reached. Flow will begin again when new filter is installed. The system includes an electronic front push bar controlled solenoid valve, and a .45 gpm self-regulating, anti-rotational bubbler head with flexible antimicrobial mouth guard, bubbler head deactivation feature, and instantaneous tankless water cooler for consistent cool water. 115 Volts, 60Hz, rated watts: 350, full load amps: 5. Dimensions: (L x W x H) 18-3/4 x 15-11/16 x 26-1/4"

## APPLICATIONS

Great for schools, office buildings, shopping malls, and other indoor environments where there is a demand for a chilled water source. CSA certified to comply with NSF/ANSI 42, NSF/ANSI 53, NSF/ANSI/CAN 61: Q ≤ 1, NSF/ANSI/CAN 372, ASME A112.18.1/CSA B125.1, ASME112.19.3/CSA B45.4, UL 399 and CSA C22.2 No. 120. ADA compliant to ICC A117.1, CSA B651, DOJ's 2010 ADA Standards for Accessible Design when properly installed. ASHRAE 18 compliant chilling capacity. FCC ID: 2AUAN-1200SF and IC: 25959-1200SF. Electric water coolers are not recommended or designed for outdoor applications or enclosed pool areas (chlorine), and failure to heed these conditions may void warranty. 5 Year Limited Warranty on the refrigeration system of the unit. Electrical components and water system are warranted for 12 months from date of installation. Warranty pertains to drinking water applications only.



**NOTES:**

1. HOLD PLUMBING & ELECTRICAL DIMENSIONS ±1/4" (6.4mm). HOLD MOUNTING DIMENSIONS ±1/8" [±3.2MM].
2. ADHERING TO PROVIDED INSTALLATION HEIGHT DIMENSIONS WILL ALLOW A SINGLE WATER COOLER OR THE LOW WATER COOLER IN A HI-LO INSTALLATION), AND THE BOTTLE FILLER (IF APPLICABLE) TO BE INSTALLED AT ADULT ADA HEIGHT. FOR INSTALLATION HEIGHTS OTHER THAN SHOWN, DIMENSIONS MARKED (\*) MUST BE ADJUSTED ACCORDINGLY. WHEN INSTALLING THIS UNIT, LOCAL, STATE, OR FEDERAL CODES SHOULD BE ADHERED TO.

**TYPICAL SINGLE (OR LOW) UNIT INSTALLATION**  
(REFRIGERATION COMPONENTS HIDDEN FOR CLARITY)

FULL SCALE  
ROUGH-IN TEMPLATE  
PN 0510001007  
AVAILABLE UPON REQUEST

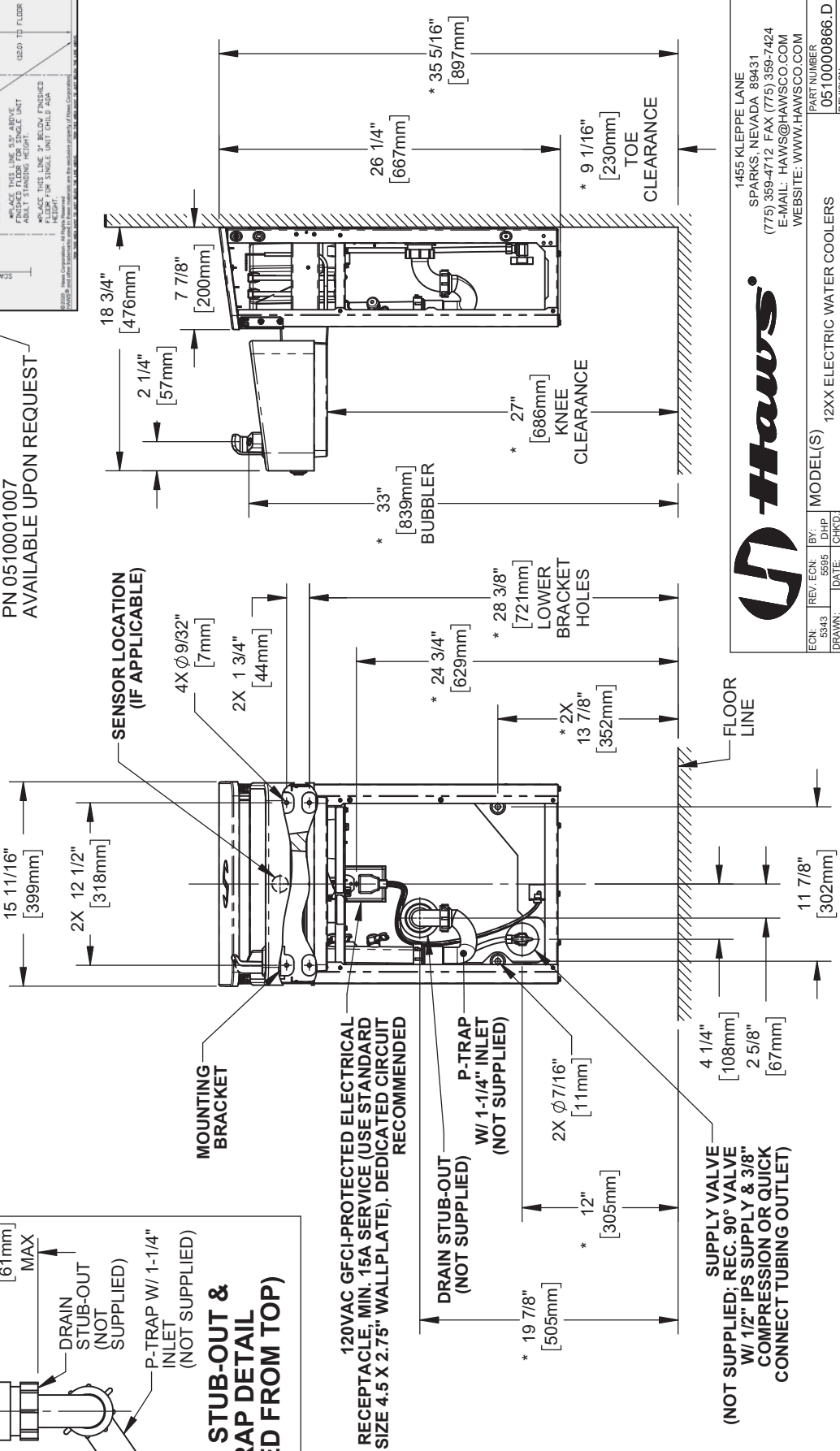
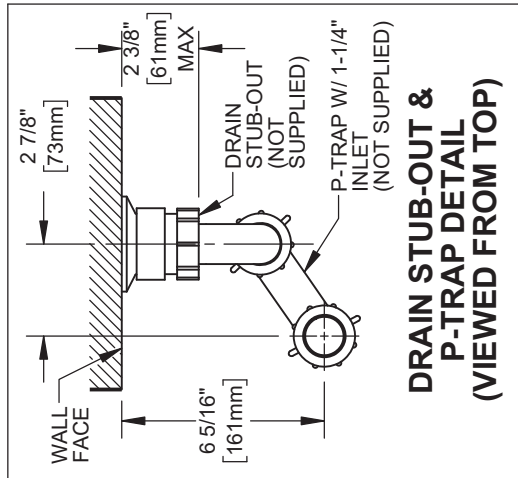
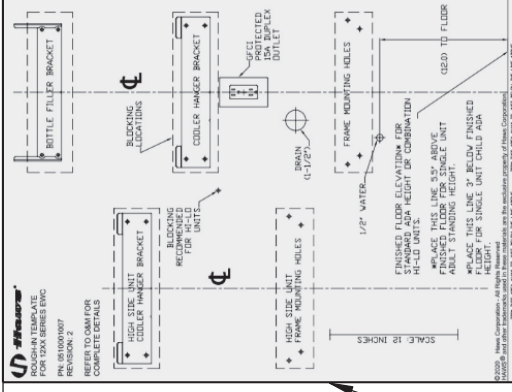

1455 KLEPPE LANE  
SPARKS, NEVADA 89431  
(775) 359-4712 FAX (775) 359-7424  
E-MAIL: HAWS@HAWS.CO.COM  
WEBSITE: WWW.HAWS.CO.COM

ECN: 5343	REV. ECN: 5343	BY: DHP	DATE: 09/28/20	SCALE: 1:12	DRAWING TYPE: INSTALLATION	SIZE: A	SHEET 1 OF 7
DRAWN: DHP	DATE: 09/28/20	CHKD: DHP	DATE: 09/28/20				
APPROVED: DHP	DATE: 09/28/20						
MODEL(S): 12XX ELECTRIC WATER COOLERS						PART NUMBER: 0510000866.D	REVISION: 6

# TYPICAL HI-LO UNIT INSTALLATION (REFRIGERATION COMPONENTS HIDDEN FOR CLARITY)

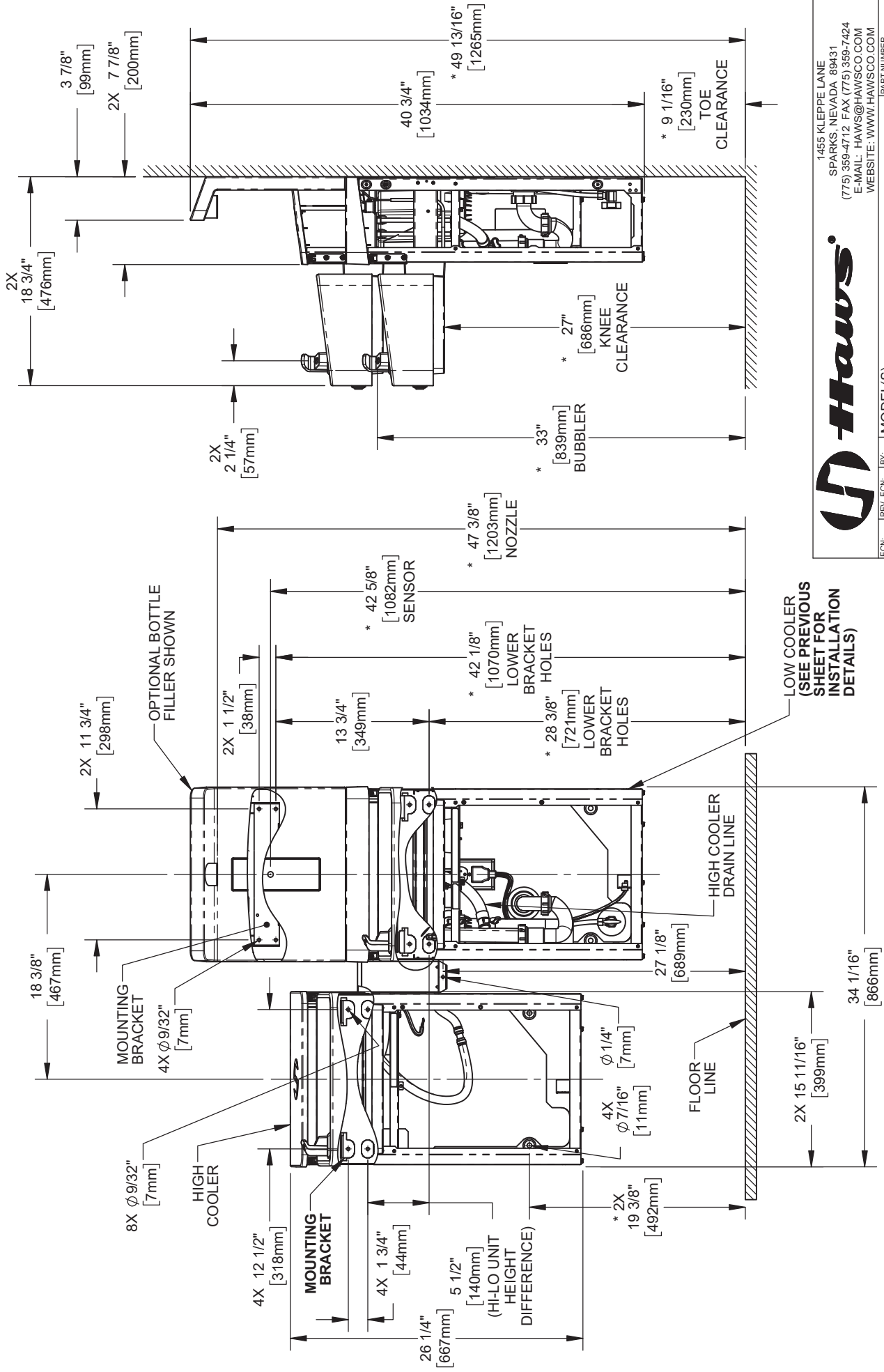

1455 KLEPPE LANE  
SPARKS, NEVADA 89431  
(775) 359-4712 FAX (775) 359-7424  
E-MAIL: HAWS@HAWS.CO.COM  
WEBSITE: WWW.HAWS.CO.COM



ECN: 5343	REV. ECN: 5343	BY: DHP	DATE: 09/28/20	SCALE: 1:12	DRAWING TYPE: INSTALLATION	SIZE: A	SHEET 2 OF 7
DRAWN: [blank]	APPROVED: [blank]	CHKD: DHP	DATE: [blank]				
MODEL(S): 12XX ELECTRIC WATER COOLERS				PART NUMBER: 0510000866.D		REVISION: 6	

# BOTTLE FILLER INSTALLATION DETAILS

THIS DOCUMENT IS TRUE AND CORRECT AT TIME OF PUBLICATION. CONTINUED PRODUCT IMPROVEMENTS MAKE SPECIFICATIONS AND MEASUREMENTS SUBJECT TO CHANGE WITHOUT NOTICE.

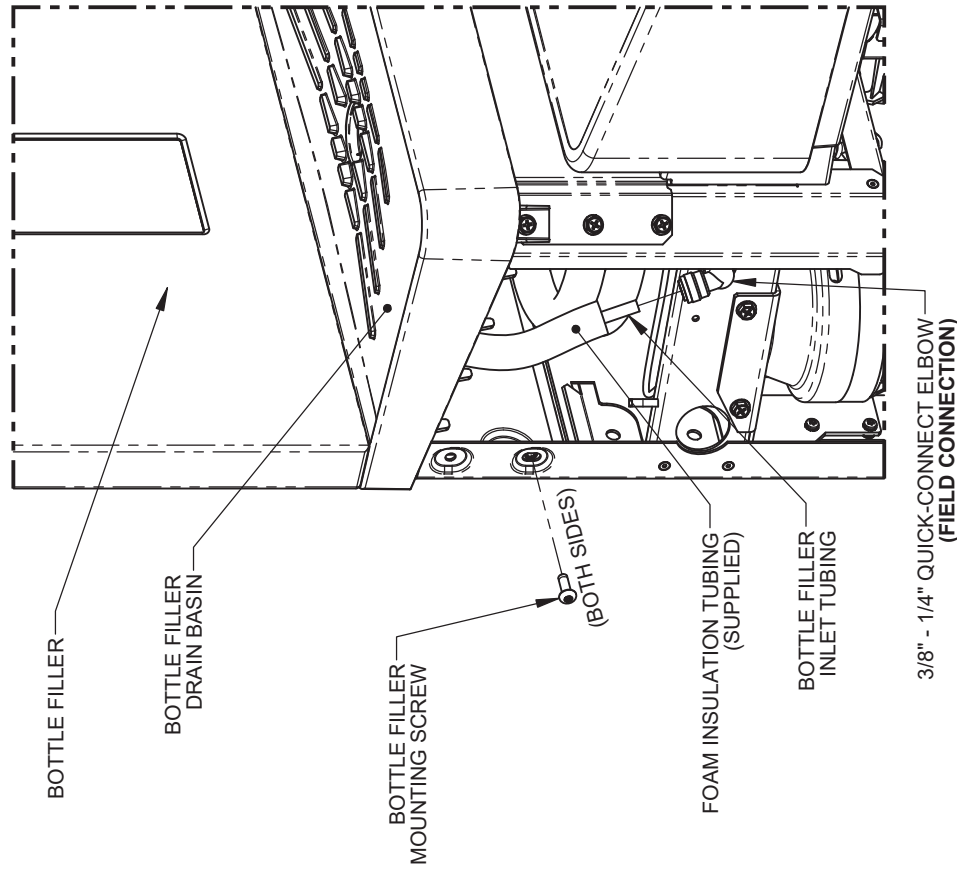
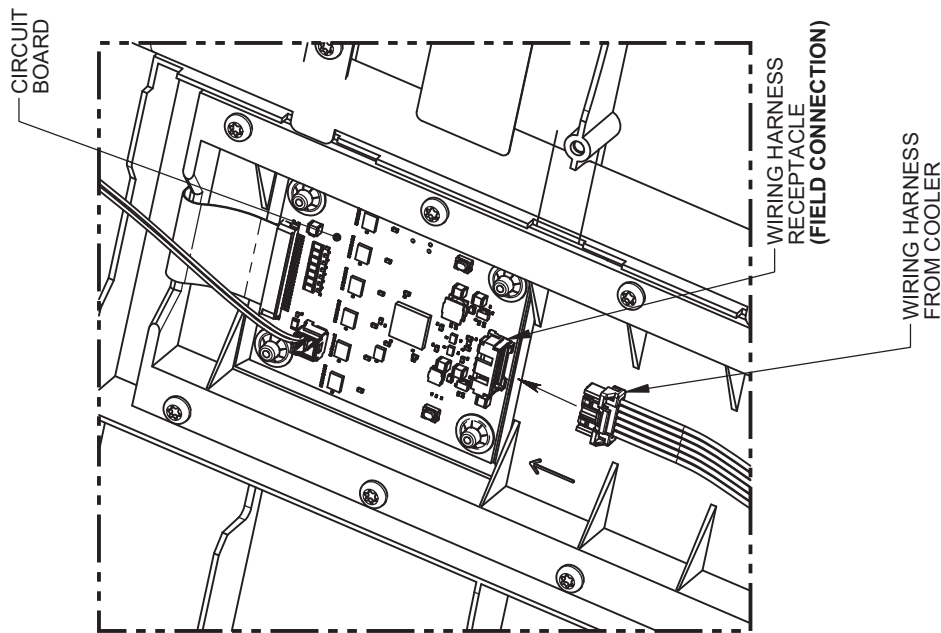

## BOTTLE FILLER MOUNTING & TUBING CONNECTION

## WIRING HARNESS CONNECTION (REAR OF BOTTLE FILLER)



1455 KLEPPE LANE  
SPARKS, NEVADA 89431  
(775) 359-4712 FAX (775) 359-7424  
E-MAIL: HAWS@HAWS.CO.COM  
WEBSITE: WWW.HAWS.CO.COM

ECN:	REV. ECN:	BY:	MODEL(S)	12XX ELECTRIC WATER COOLERS	PART NUMBER
5343	5595	DHP			0510000866.D
DRAWN:	DATE:	CHKD:			REVISION
	07/25/18	DHP			6
APPROVED:	DATE:	TM	SCALE:	1:12	DRAWING TYPE:
	09/28/20				INSTALLATION
					SIZE: A
					SHEET 3 OF 7

THIS DOCUMENT IS TRUE AND CORRECT AT TIME OF PUBLICATION. CONTINUED PRODUCT IMPROVEMENTS MAKE SPECIFICATIONS AND MEASUREMENTS SUBJECT TO CHANGE WITHOUT NOTICE.

# HIGH EWC INSTALLATION DETAILS

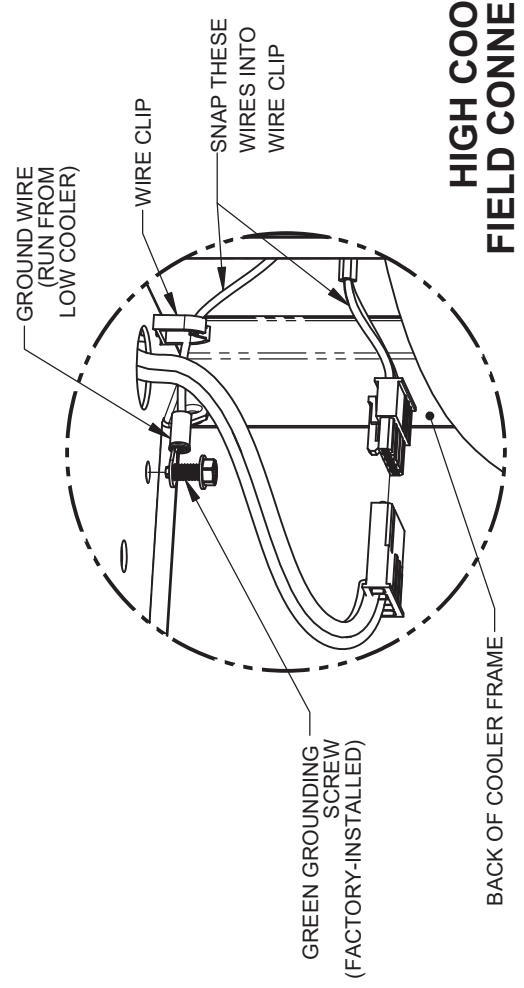
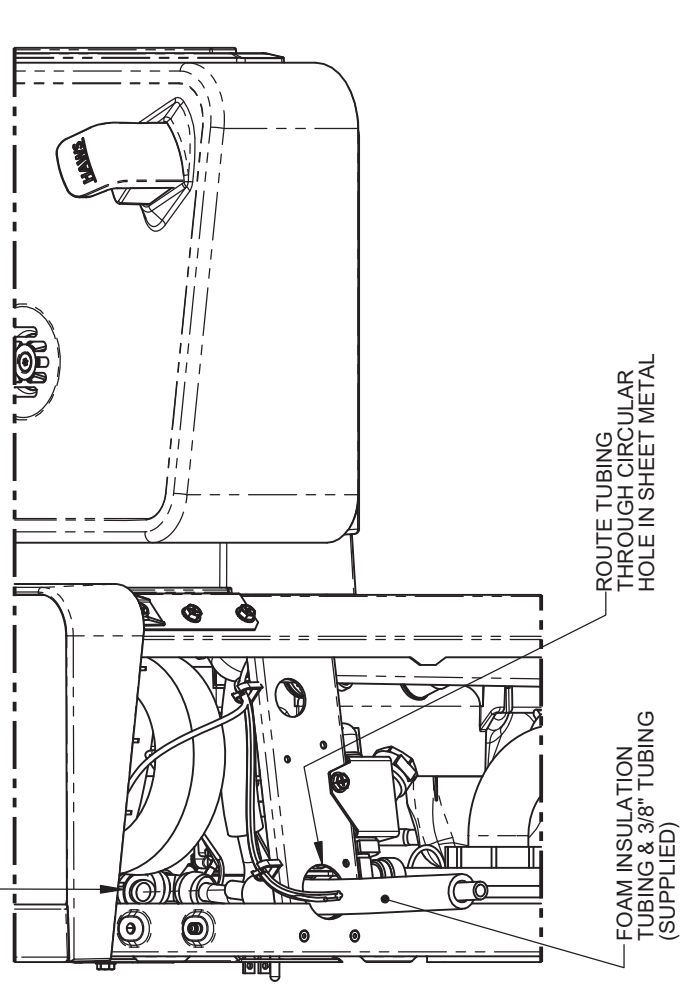
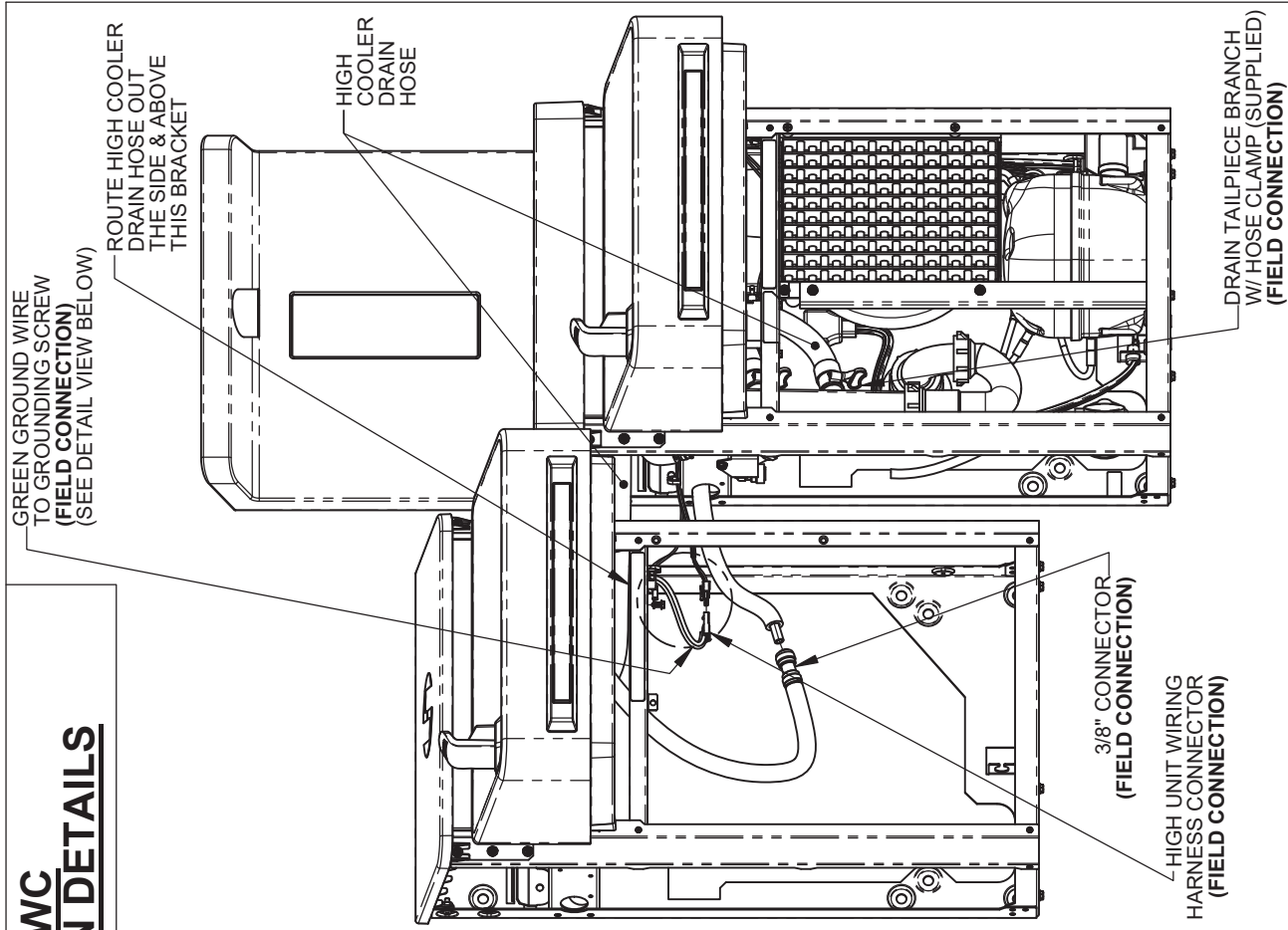

1455 KLEPPE LANE  
SPARKS, NEVADA 89431  
(775) 359-4712 FAX (775) 359-7424  
E-MAIL: HAWS@HAWS.CO.COM  
WEBSITE: WWW.HAWS.CO.COM

ECN: 5343	REV. ECN: 5343	BY: DHP	DATE: 09/28/20	SCALE: 1/24	DRAWING TYPE: INSTALLATION	SIZE: A	SHEET 4 OF 7
DRAWN: DHP	DATE: 09/28/20	CHKD: DHP	DATE: 09/28/20				
APPROVED: [Signature]							
MODEL(S): 12XX ELECTRIC WATER COOLERS		PART NUMBER: 0510000866.D		REVISION: 6			

BACK OF COOLER FRAME

# RETROFIT INSTALLATION DETAILS

## LOW COOLER BRACKET HEIGHT

ADULT STANDING	ADULT ADA	CHILD ADA
33 7/8"	28 3/8"	25 3/8"

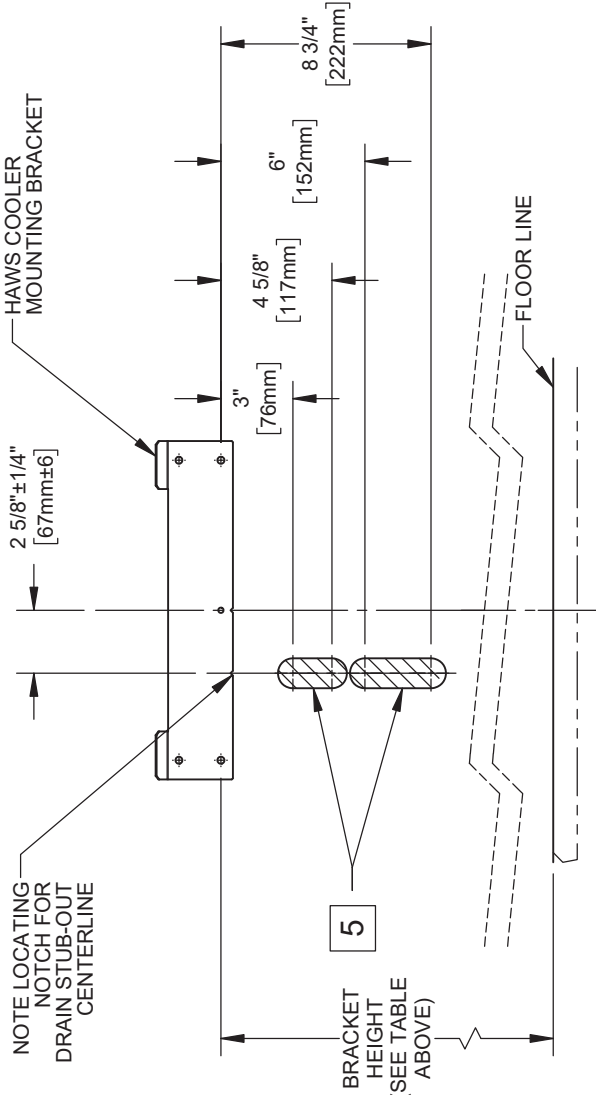

## PERMISSIBLE LOCATIONS FOR DRAIN STUB-OUT

NOTES:

- 3 THE 12XX COOLER SERIES IS ABLE TO RETROFIT IN PLACE OF A NUMBER OF COMPETITOR MODELS. SEE RETROFIT TABLE ABOVE FOR PARTIAL LIST OF COOLERS ABLE TO BE REPLACED BY THIS ONE. **THE FOLLOWING DISCLAIMERS APPLY:**
  - THE 12XX COOLER CENTERLINE MAY NOT MATCH THE OLD COOLER'S CENTERLINE, SINCE THE 12XX COOLER DRAIN MUST BE 2 5/8" OFF OF CENTER. THIS MAY AFFECT ADA COMPLIANCE.
  - FOR HI-LO COOLER RETROFITS, EXISTING RIGHT-SIDE COOLER MUST BE THE LOW COOLER. DRAIN, WATER, AND ELECTRIC SERVICES MUST BE POSITIONED BEHIND RIGHT-SIDE UNIT.
  - THERE MUST BE WALL BLOCKING OR OTHER STRUCTURAL MATERIAL BEHIND HAWS MOUNTING HOLES. VERIFY THAT DRAIN, ELECTRIC, & WATER SERVICES ARE LOCATED WITHIN BOUNDARIES SPECIFIED ON THIS SHEET AND THE NEXT. SOME RETROFITS MAY REQUIRE THE ELECTRIC OUTLET TO BE MOVED.
- 4 THE P-TRAP IS NOT SUPPLIED. THE VERTICAL DIMENSIONS GIVEN ARE BASED UPON INSTALLATION USING OF A KEENEY 200W P-TRAP, AND SHOULD THEREFORE BE REGARDED AS REFERENCE-ONLY.
- 5 THE CENTERLINE OF THE DRAIN STUB-OUT MUST BE BETWEEN 3" [76mm] & 4-5/8" [118mm] OR BETWEEN 6" [152mm] & 8-3/4" [222mm] BELOW THE LOWERMOST EWC MOUNTING BRACKET HOLES IN ORDER FOR THE P-TRAP TO AFFIX PROPERLY TO THE DRAIN TAILPIECE.
  - DEPENDING ON STUB-OUT HEIGHT, SOME TRIMMING OF THE TAILPIECE WILL BE REQUIRED.
  - MOUNTING THE STUB-OUT IN THE HIGHER RANGE WILL REQUIRE TRIMMING THE TAILPIECE ABOVE THE LOWER DRAIN HOSE BRANCH. **IN THIS INSTANCE, THEREFORE, A HI-LO COOLER CANNOT BE INSTALLED.**
- 6 WHATEVER P-TRAP AND STUB-OUT PLUMBING ARE USED, CARE SHOULD BE TAKEN TO ENSURE THAT THE P-TRAP CAN SEAL TO THE STUB-OUT PROPERLY AND STILL ALIGN TO THE DRAIN TAILPIECE (LOCATED AT THE GIVEN DIMENSIONS).

<b>3 RETROFIT TABLE</b>	
<b>MANUFACTURER</b>	<b>MODEL</b>
HAWS	ALL MODELS STARTING WITH HWUACP
ELKAY/HALSEY TAYLOR	- ALL MODELS STARTING WITH EB, EI, EMA, EN, EZ, HAC HVR, LI, LMA, LZ, TB, & TI - SINGLE COOLER MODELS STARTING WITH VRC & LVR
OASIS	ALL VERSACOOLER II MODELS
SUNROC	ALL MODELS STARTING WITH ADA A171, A171.8, & A172.8UBL MODELS
MURDOCK	NOTE: THE WATER STOP VALVE MUST BE RELOCATED TO RETROFIT A FILTERED 12XX COOLER

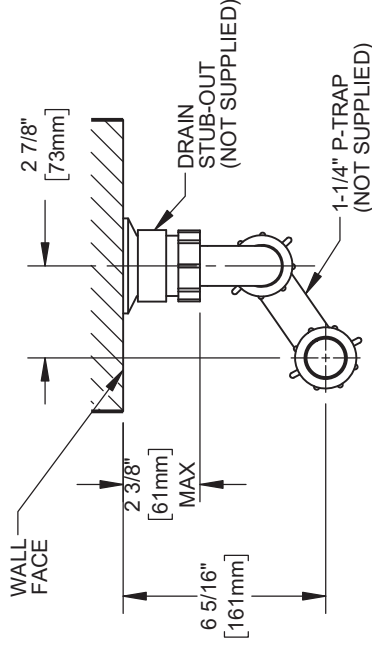

## DRAIN STUB-OUT/P-TRAP DETAIL (VIEWED FROM TOP)

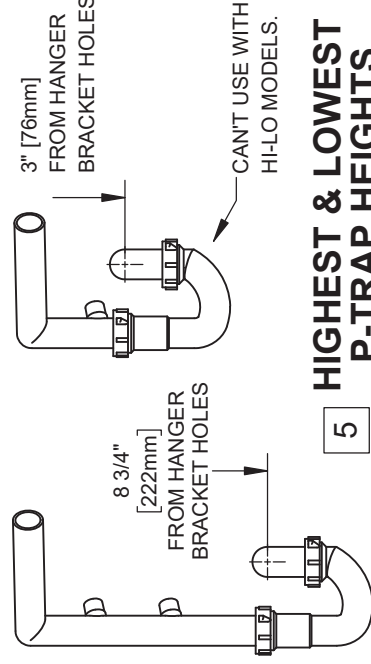

## HIGHEST & LOWEST P-TRAP HEIGHTS



1455 KLEPPE LANE  
SPARKS, NEVADA 89431  
(775) 359-4712 FAX (775) 359-7424  
E-MAIL: HAWS@HAWSCO.COM  
WEBSITE: WWW.HAWSCO.COM

ECN: 3543	REV. ECN: 5995	BY: DHP	MODEL(S): 12XX ELECTRIC WATER COOLERS	PART NUMBER: 0510000866.D
DRAWN: DATE: 09/28/20	DATE: 09/28/20	CHKD: DHP	INSTALLATION: 12XX ELECTRIC WATER COOLERS	REVISION: 6
APPROVED: TM	SCALE: 1:8	DRAWING TYPE: INSTALLATION	SIZE: A	SHEET 5 OF 7

# RETROFIT INSTALLATION DETAILS

THIS DOCUMENT IS TRUE AND CORRECT AT TIME OF PUBLICATION. CONTINUED PRODUCT IMPROVEMENTS MAKE SPECIFICATIONS AND MEASUREMENTS SUBJECT TO CHANGE WITHOUT NOTICE.

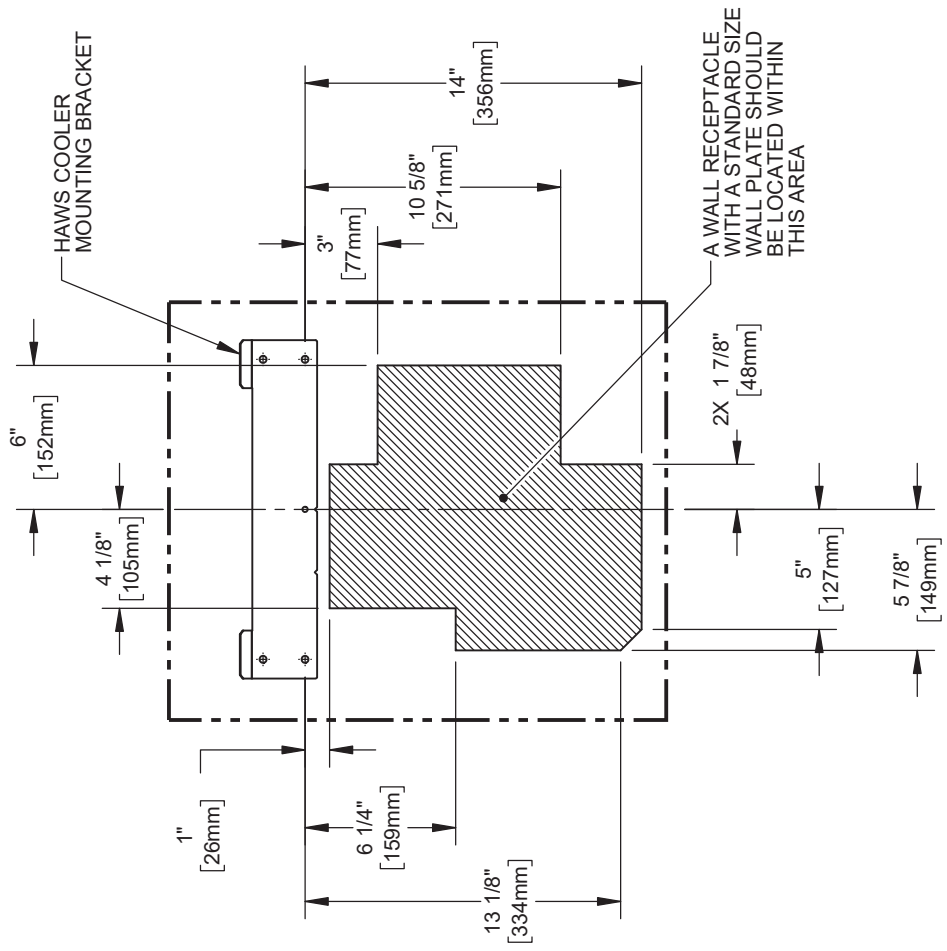
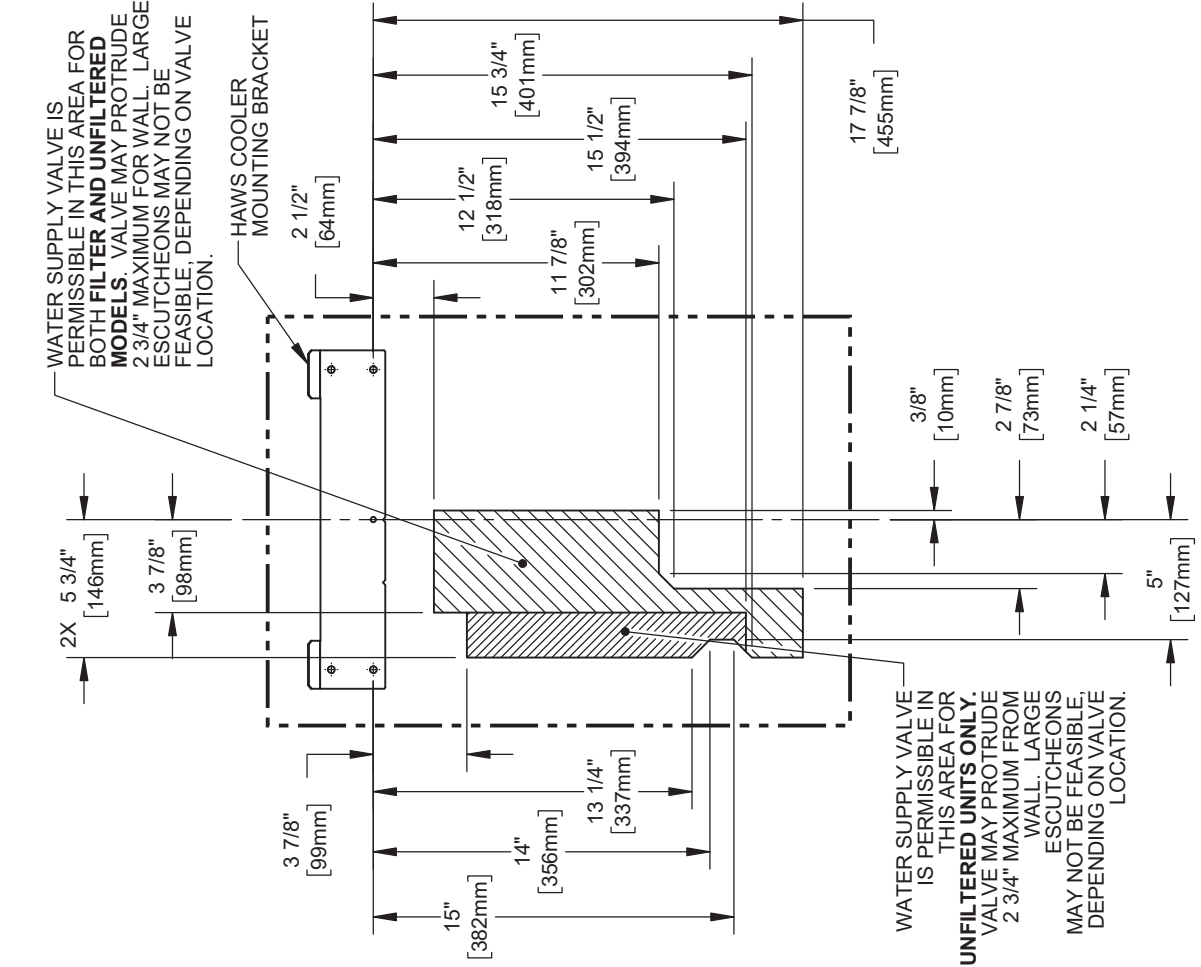

1455 KLEPPE LANE  
SPARKS, NEVADA 89431  
(775) 359-4712 FAX (775) 359-7424  
E-MAIL: HAWS@HAWS.CO.COM  
WEBSITE: WWW.HAWS.CO.COM

ECN: 3343	REV. EON: 5995	BY: DHP	MODEL(S): 12XX ELECTRIC WATER COOLERS	PART NUMBER: 0510000866.D
DRAWN: 07/15/18	DATE: 07/15/18	CHKD: DHP	INSTALLATION: 13	REVISION: 6
APPROVED: [Signature]	DATE: 09/28/20	TM	DRAWING TYPE: 18	SIZE: A
			SHEET 6 OF 7	

# MAINTENANCE

THIS DOCUMENT IS TRUE AND CORRECT AT TIME OF PUBLICATION. CONTINUED PRODUCT IMPROVEMENTS MAKE SPECIFICATIONS AND MEASUREMENTS SUBJECT TO CHANGE WITHOUT NOTICE.

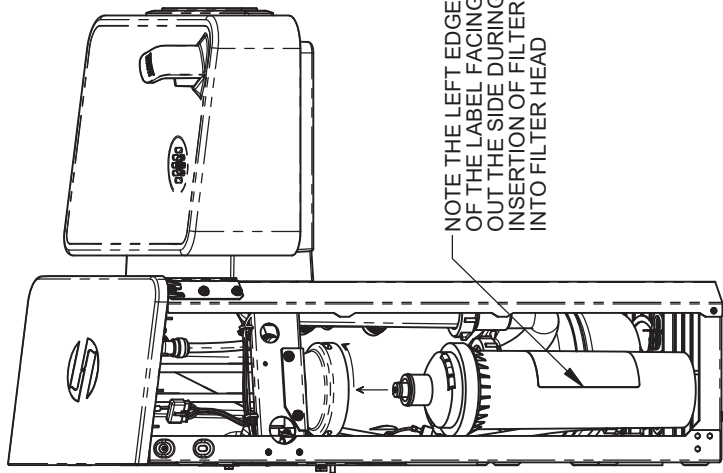

## FILTER REPLACEMENT

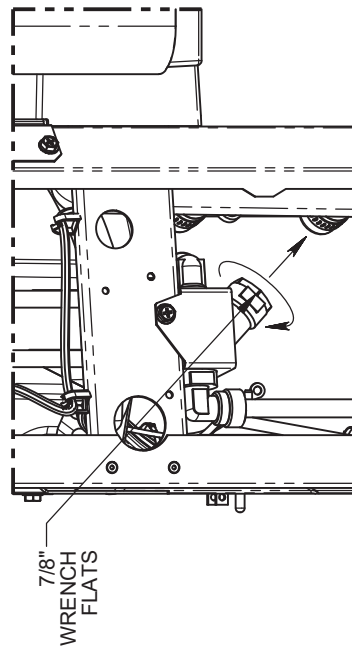

## Y-STRAINER CLEANING



1455 KLEPPE LANE  
 SPARKS, NEVADA 89431  
 (775) 359-4712 FAX (775) 359-7424  
 E-MAIL: HAWS@HAWS.CO.COM  
 WEBSITE: WWW.HAWS.CO.COM

ECN:	REV. ECN:	BY:	MODEL(S)	PART NUMBER
5343	5995	DHP	12XX ELECTRIC WATER COOLERS	0510000866.D
DRAWN:	DATE:	CHKD:	INSTALLATION	REVISION
APPROVED:	DATE:	DHP	SCALE: 1:8	6
	09/29/20		DRAWING TYPE	SIZE: A
				SHEET 7 OF 7