

## FEATURES & BENEFITS

### SMART ENERGY SAVINGS MODE

Energy saving feature allows unit to power off the refrigeration system after 2 hours of non-use and dark ambient light conditions. Unit will automatically start back up next time unit is used or lights are turned back on.

### PROGRAMMABLE FEATURES

Program your cooler to be in off mode during planned facility shut downs, change the settings on the digital readout for bright or dim display, adjust sensor range, and review settings and error codes.

### VANDAL RESISTANT FEATURES

Exceptional vandal resistance features include a hidden programming button, anti-rotational bubbler head with an optional stainless steel bubbler head, UPC impact tested bowl supports, Torx bit access screws, steel frame, and fasteners hidden from public view.

### UNIVERSAL MOUNTING

Specially designed internal configuration allows for mounting over existing competitors rough-ins.

### BUBBLER HEAD

Bubbler features a flexible antimicrobial mouth guard to protect against injury and microorganisms. Anti-rotational design prevents unwanted attempts to remove or rotate the head.

### ELECTRONIC DISPLAY

Intuitive LED electronic display educates users when the bottle filler is activated, when the water is being filtered and how many plastic bottles have been saved.

### BOTTLE FILLER

Quick fill sensor-operated bottle filler is accessible to all users, has LED lighting to illuminate the fill area, and an integral basin that drains directly to the waste.

### AUTO PURGE

Bottle filler automatically purges the water line after 24 hours of non-use to prevent the development and growth of Legionella and other harmful bacteria.

## OPTIONS

- Bubbler Head: Model 5716, stainless steel bubbler head for the Haws 1200 series water coolers.
- Cane Detection, Floor Mounted: Model SK6, floor mounted cane detection for the Haws Hi-Lo drinking fountains.

For more information, visit [www.hawsc.com](http://www.hawsc.com) or call (888) 640-4297.



## SPECIFICATIONS

Model 1212S indoor wall-mount ADA Hi-Lo stainless steel water cooler and bottle filler shall include an ASHRAE compliant, hermetically sealed R-134a refrigeration system with thermostat. Unit features a unique, modern Hi-Lo (dual fountain) design with 304 satin finish stainless steel outer shell. Energy savings feature powers down refrigeration system after 2 hours of non-use and the lights shut off, and will automatically start again when used. The unit can also be programmed to shut down during planned facility closures, weekends, etc. Digital LED interface keeps user apprised of programming and error codes. Bottle filler basin drains directly to the units waste. The system includes electronic front push bar controlled solenoid valves, .45 gpm self-regulating, anti-rotational bubbler heads with flexible antimicrobial mouth guards, bubbler head deactivation feature, bottle filler auto purge every 24 hours, instantaneous tankless water cooler for consistent cool water, and LED illuminated bottle fill area. 115 Volts, 60Hz, rated watts: 350, full load amps: 5. Dimensions: (L x W x H) 18-3/4 x 34-1/16 x 40-3/4"

## APPLICATIONS

Great for schools, office buildings, shopping malls, and other indoor environments where there is a demand for a chilled water source. CSA certified to comply with NSF/ANSI/CAN 61:  $Q \leq 1$ , NSF/ANSI/CAN 372, ASME A112.18.1/CSA B125.1, ASME 112.19.3/CSA B45.4, UL 399 and CSA C22.2 No. 120. ADA compliant to ICC A117.1, CSA B651, DOJ's 2010 ADA Standards for Accessible Design when properly installed. ASHRAE 18 compliant chilling capacity. FCC and CAN ICES - 3(A)/NMB-3(A). Electric water coolers are not recommended or designed for outdoor applications or enclosed pool areas (chlorine), and failure to heed these conditions may void warranty.



**NOTES:**

1. HOLD PLUMBING & ELECTRICAL DIMENSIONS ±1/4" (6.4mm). HOLD MOUNTING DIMENSIONS ±1/8" [±3.2MM].
2. ADHERING TO PROVIDED INSTALLATION HEIGHT DIMENSIONS WILL ALLOW A SINGLE WATER COOLER OR THE LOW WATER COOLER IN A HI-LO INSTALLATION), AND THE BOTTLE FILLER (IF APPLICABLE) TO BE INSTALLED AT ADULT ADA HEIGHT. FOR INSTALLATION HEIGHTS OTHER THAN SHOWN, DIMENSIONS MARKED (\*) MUST BE ADJUSTED ACCORDINGLY. WHEN INSTALLING THIS UNIT, LOCAL, STATE, OR FEDERAL CODES SHOULD BE ADHERED TO.

**TYPICAL SINGLE (OR LOW) UNIT INSTALLATION**  
(REFRIGERATION COMPONENTS HIDDEN FOR CLARITY)

FULL SCALE  
ROUGH-IN TEMPLATE  
PN 0510001007  
AVAILABLE UPON REQUEST

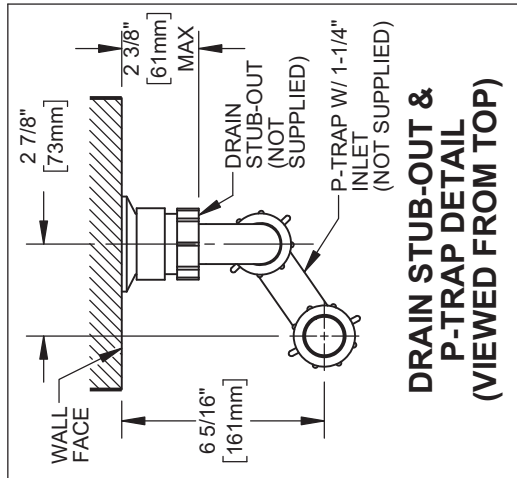
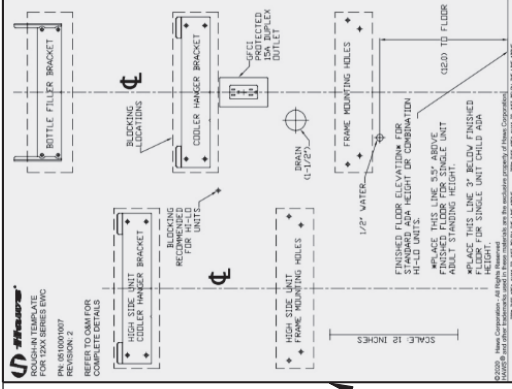

**DRAIN STUB-OUT & P-TRAP DETAIL (VIEWED FROM TOP)**

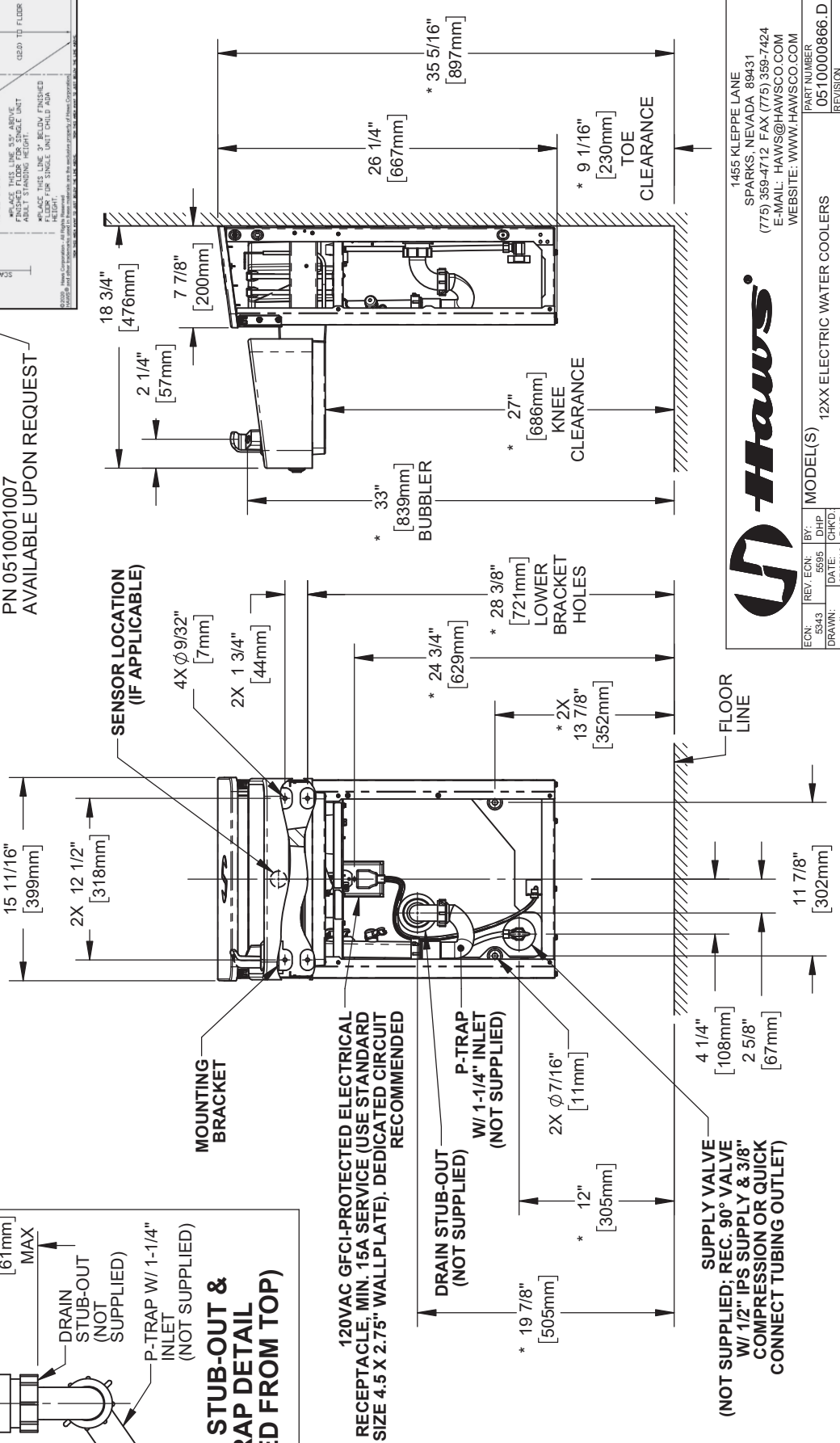

120VAC GFCI-PROTECTED ELECTRICAL RECEPTACLE, MIN. 15A SERVICE (USE STANDARD SIZE 4.5 X 2.75\"/>

SUPPLY VALVE (NOT SUPPLIED); REC. 90° VALVE W/ 1/2\"/>



1455 KLEPPE LANE  
SPARKS, NEVADA 89431  
(775) 359-4712 FAX (775) 359-7424  
E-MAIL: HAWS@HAWS.CO.COM  
WEBSITE: WWW.HAWS.CO.COM

ECN: 5343	REV. ECN: 5343	BY: DHP	MODEL(S): 12XX ELECTRIC WATER COOLERS	PART NUMBER: 0510000866.D
DRAWN: DHP	DATE: 07/15/16	CHKD: DHP	INSTALLATION: 6	REVISION: 6
APPROVED: TM	DATE: 09/29/20	SCALE: 1:12	DRAWING TYPE: INSTALLATION	SIZE: A

© 2020 Haws Corporation. All Rights Reserved.

# TYPICAL HI-LO UNIT INSTALLATION

(REFRIGERATION COMPONENTS HIDDEN FOR CLARITY)

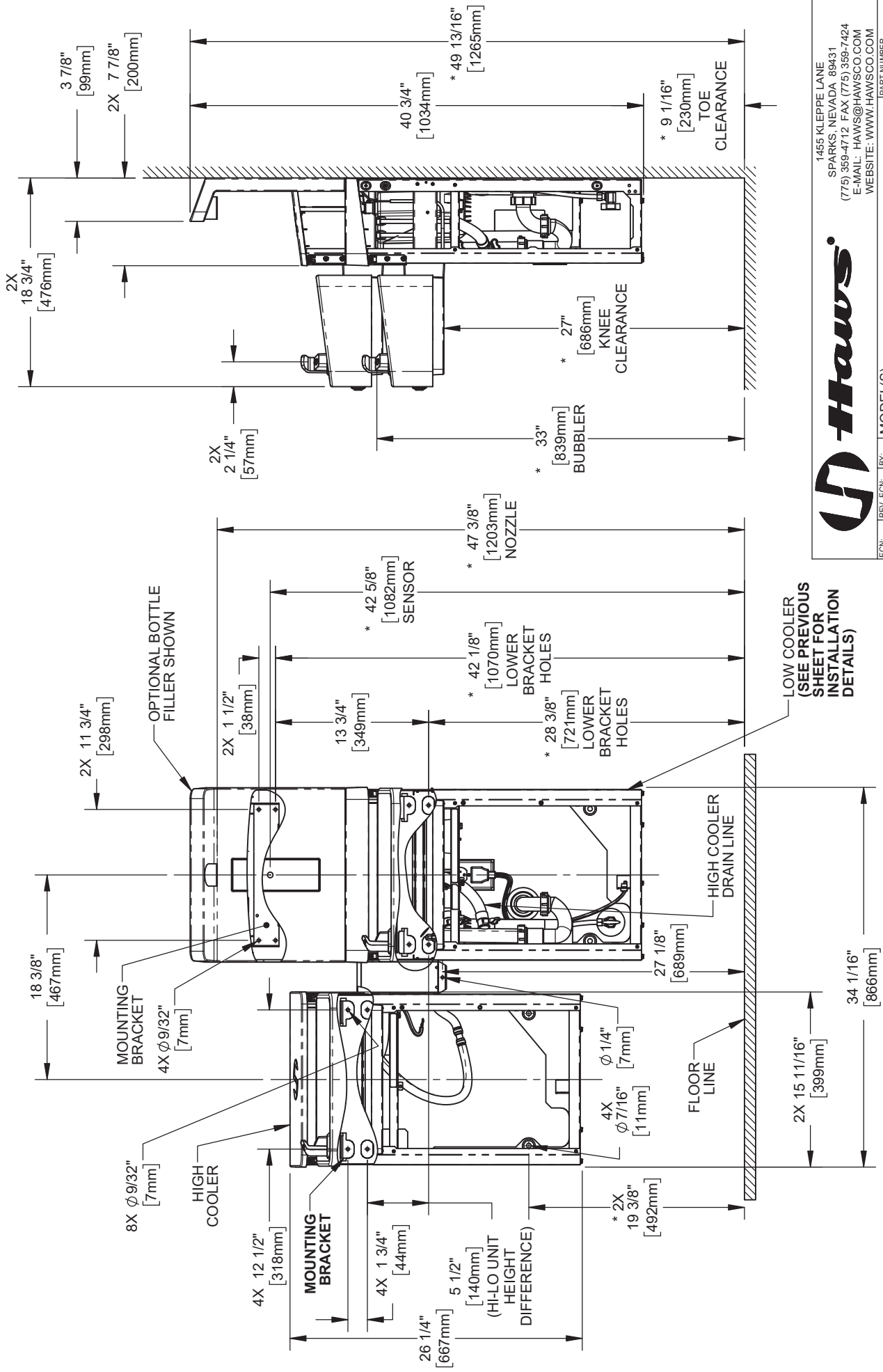

1455 KLEPPE LANE  
 SPARKS, NEVADA 89431  
 (775) 359-4712 FAX (775) 359-7424  
 E-MAIL: HAWS@HAWS.CO.COM  
 WEBSITE: WWW.HAWS.CO.COM

ECN: 5343	REV. EON: 5595	BY: DHP	MODEL(S): 12XX ELECTRIC WATER COOLERS	INSTALLATION: A	SIZE: 6	SHEET 2 OF 7
DRAWN: [ ]	DATE: [ ]	CHKD: [ ]	PART NUMBER: 0510000866.D	REVISION: 6		
APPROVED: [ ]	DATE: 09/29/20	TM	SCALE: 1:12	DRAWING TYPE: INSTALLATION		

# BOTTLE FILLER INSTALLATION DETAILS

THIS DOCUMENT IS TRUE AND CORRECT AT TIME OF PUBLICATION. CONTINUED PRODUCT IMPROVEMENTS MAKE SPECIFICATIONS AND MEASUREMENTS SUBJECT TO CHANGE WITHOUT NOTICE.

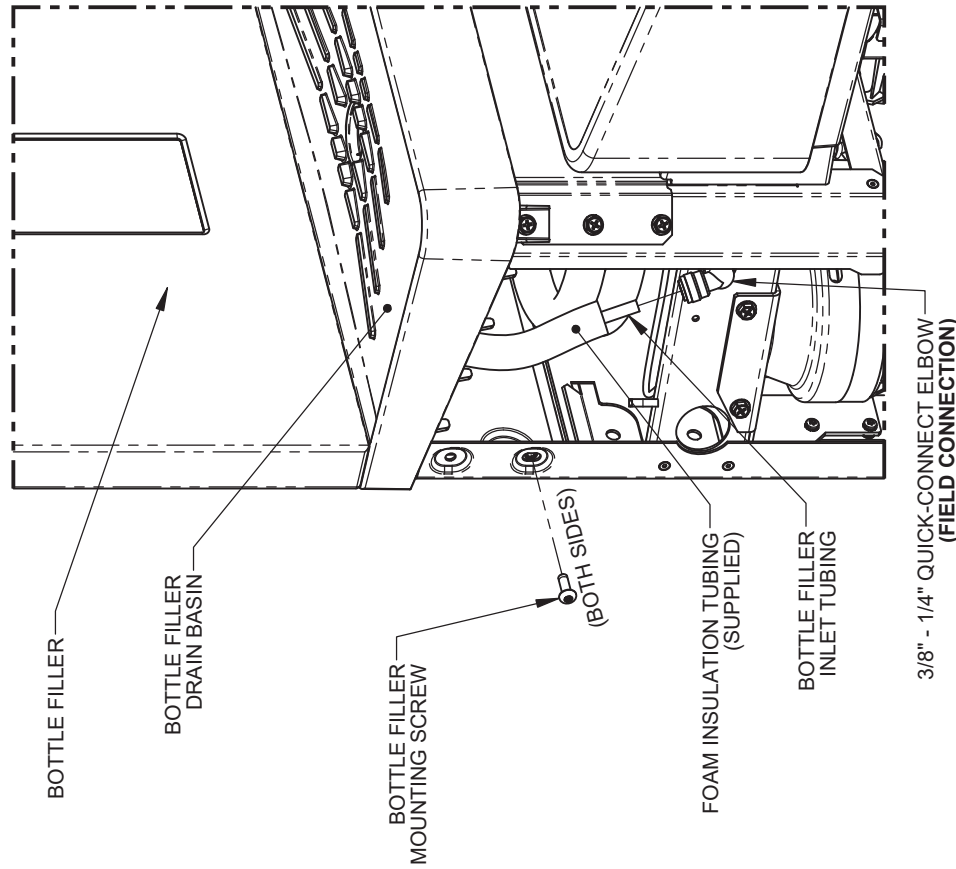
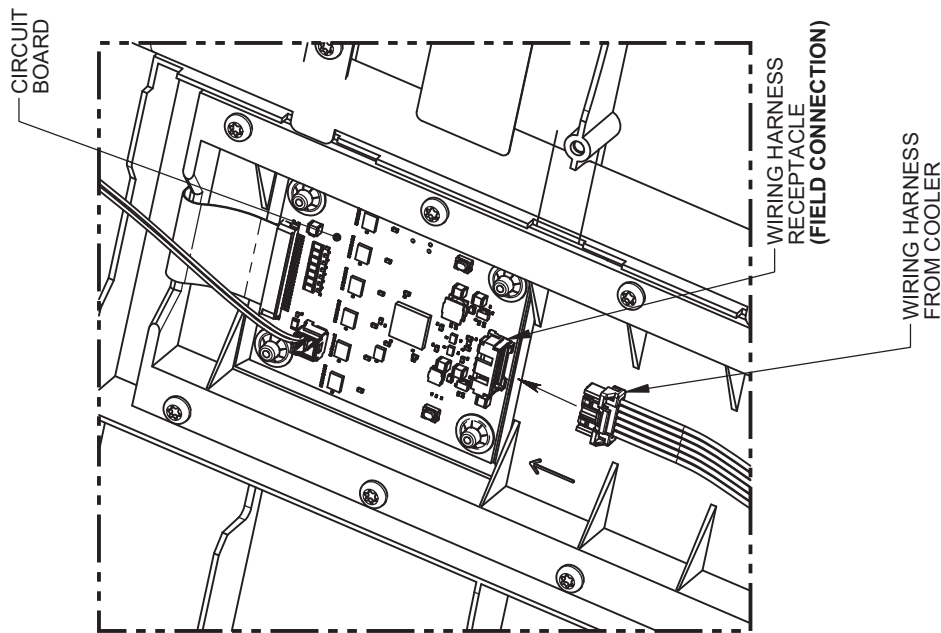

## BOTTLE FILLER MOUNTING & TUBING CONNECTION

## WIRING HARNESS CONNECTION (REAR OF BOTTLE FILLER)



1455 KLEPPE LANE  
SPARKS, NEVADA 89431  
(775) 359-4712 FAX (775) 359-7424  
E-MAIL: HAWS@HAWS.CO.COM  
WEBSITE: WWW.HAWS.CO.COM

ECN:	REV. ECN:	BY:	MODEL(S)	12XX ELECTRIC WATER COOLERS	PART NUMBER
5343	5595	DHP			0510000866.D
DRAWN:	DATE:	CHKD:			REVISION
	07/25/18	DHP			6
APPROVED:	DATE:	TM	SCALE:	1:12	DRAWING TYPE:
	09/28/20				INSTALLATION
					SIZE: A
					SHEET 3 OF 7

THIS DOCUMENT IS TRUE AND CORRECT AT TIME OF PUBLICATION. CONTINUED PRODUCT IMPROVEMENTS MAKE SPECIFICATIONS AND MEASUREMENTS SUBJECT TO CHANGE WITHOUT NOTICE.

# HIGH EWC INSTALLATION DETAILS

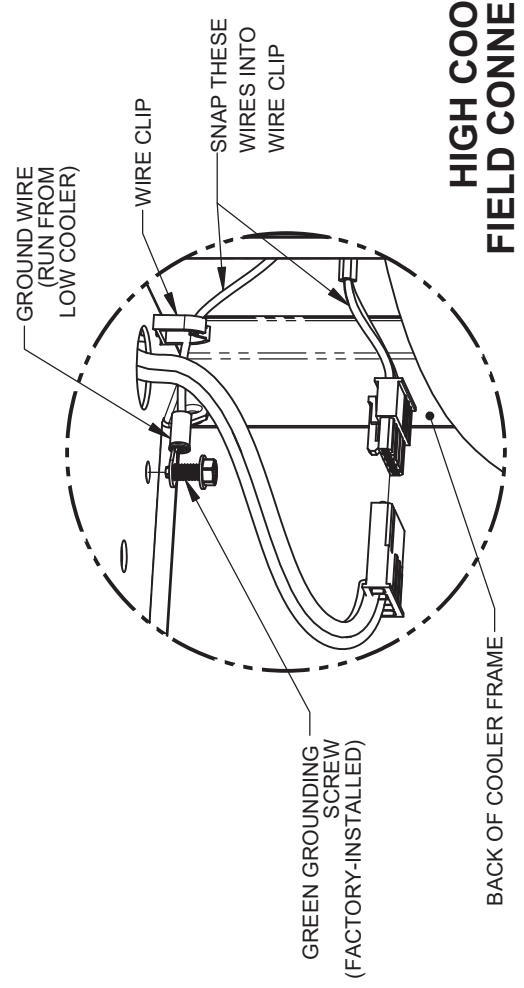
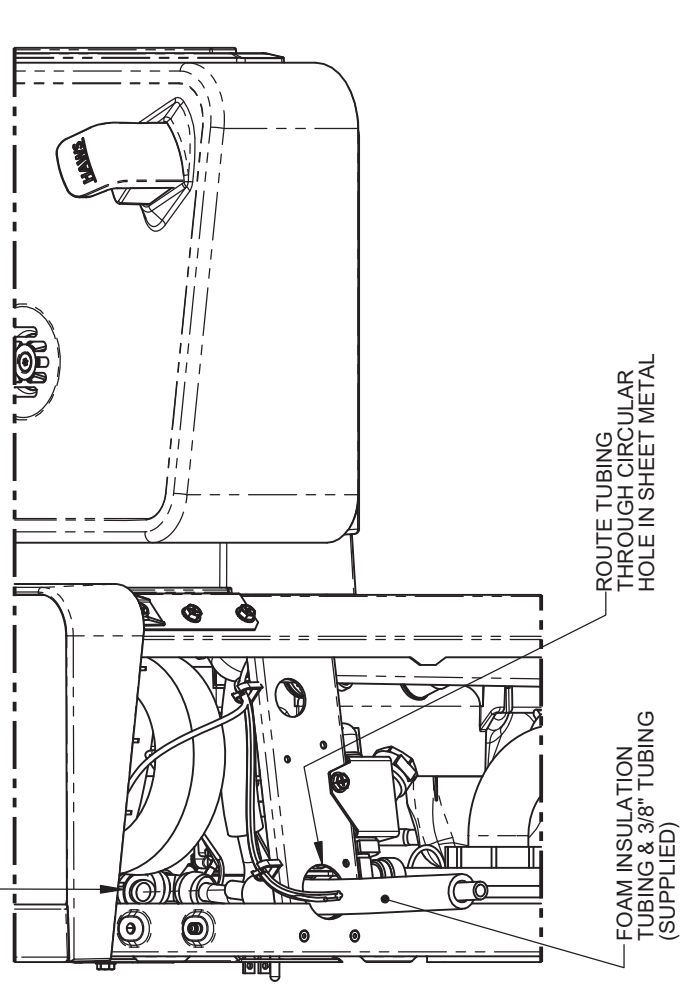
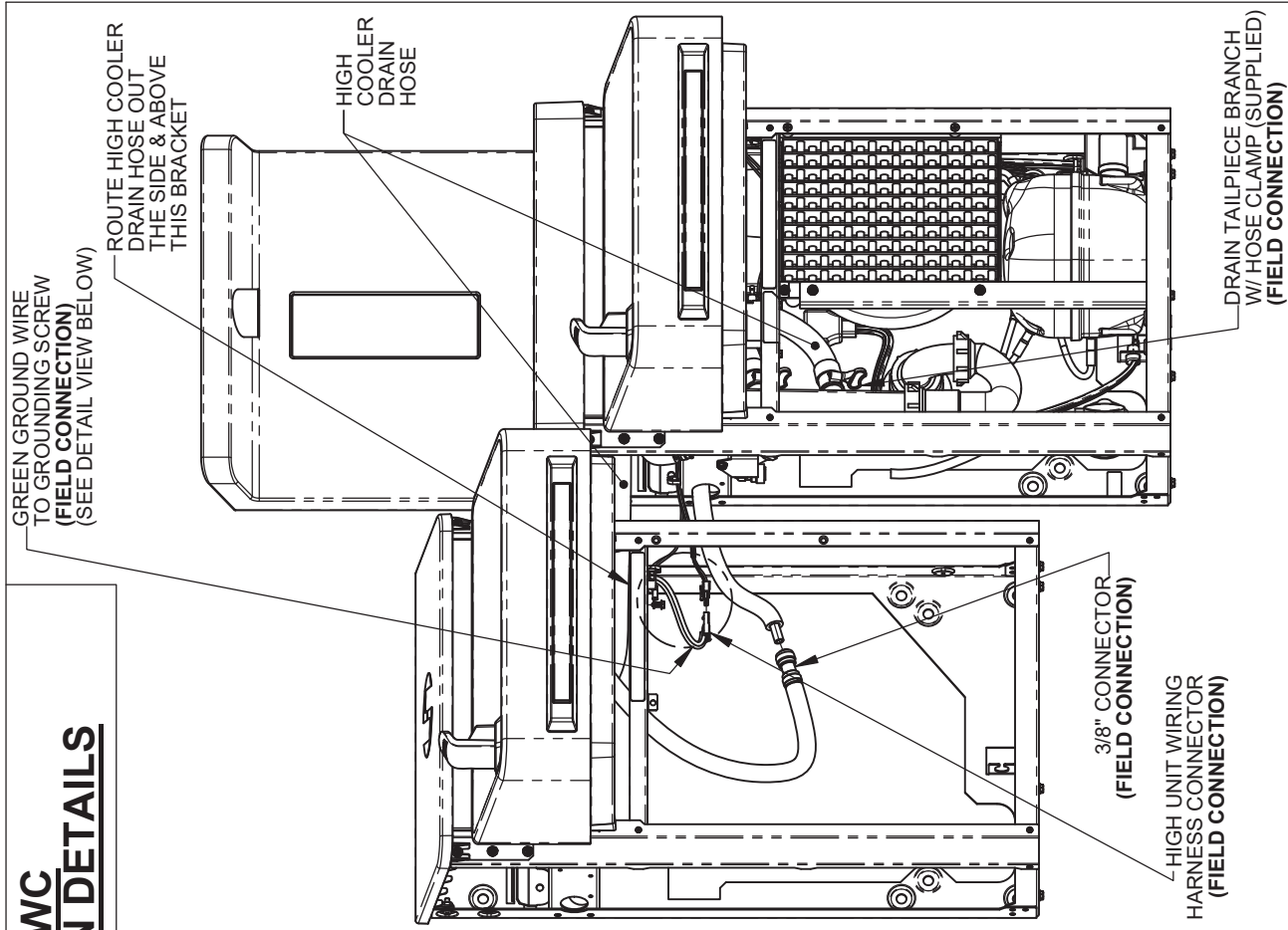

1455 KLEPPE LANE  
SPARKS, NEVADA 89431  
(775) 359-4712 FAX (775) 359-7424  
E-MAIL: HAWS@HAWS.CO.COM  
WEBSITE: WWW.HAWS.CO.COM

ECN: 5343	REV. ECN: 5343	BY: DHP	DATE: 09/28/20	SCALE: 1/24	DRAWING TYPE: INSTALLATION	SIZE: A	SHEET 4 OF 7
DRAWN: [Signature]	DATE: 09/28/20	CHKD: [Signature]	DATE: 09/28/20				
MODEL(S): 12XX ELECTRIC WATER COOLERS		PART NUMBER: 0510000866.D		REVISION: 6			

BACK OF COOLER FRAME



# RETROFIT INSTALLATION DETAILS

<b>3</b> RETROFIT TABLE	
<b>MANUFACTURER</b>	<b>MODEL</b>
HAWS	ALL MODELS STARTING WITH HWUACP
ELKAY/HALSEY TAYLOR	- ALL MODELS STARTING WITH EB, EI, EMA, EN, EZ, HAC HVR, LI, LMA, LZ, TB, & TI - SINGLE COOLER MODELS STARTING WITH VRC & LVR
OASIS	ALL VERSACOOLER II MODELS
SUNROC	ALL MODELS STARTING WITH ADA A171, A171.8, & A172.8UBL MODELS
MURDOCK	NOTE: THE WATER STOP VALVE MUST BE RELOCATED TO RETROFIT A FILTERED 12XX COOLER

<b>LOW COOLER BRACKET HEIGHT</b>	
ADULT STANDING	CHILD ADA
33 7/8"	25 3/8"
ADULT ADA	
28 3/8"	

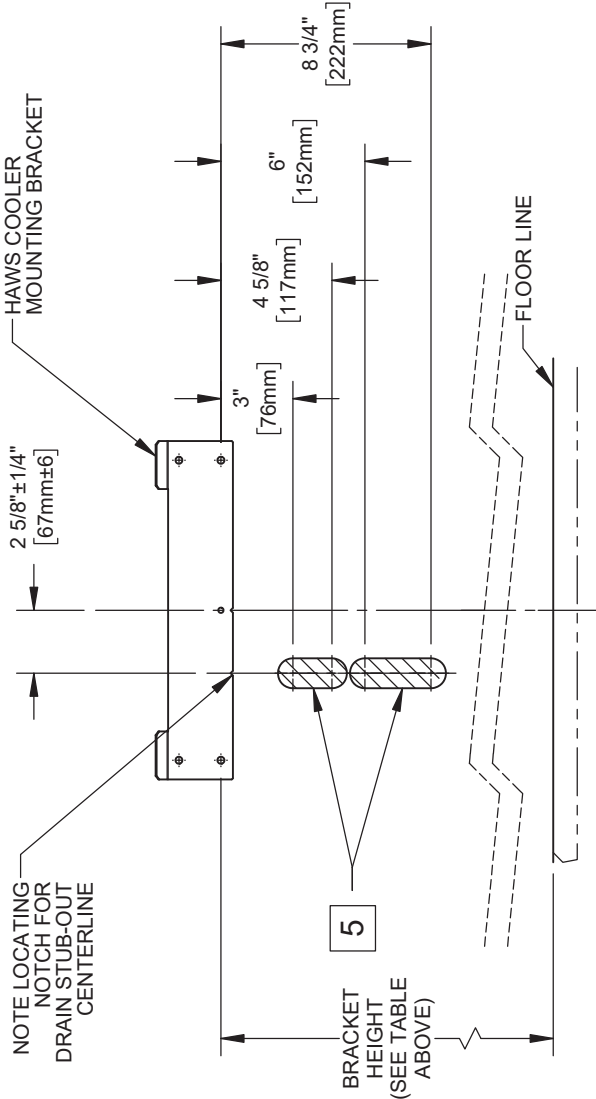

## PERMISSIBLE LOCATIONS FOR DRAIN STUB-OUT

- NOTES:**
- 3** THE 12XX COOLER SERIES IS ABLE TO RETROFIT IN PLACE OF A NUMBER OF COMPETITOR MODELS. SEE RETROFIT TABLE ABOVE FOR PARTIAL LIST OF COOLERS ABLE TO BE REPLACED BY THIS ONE. **THE FOLLOWING DISCLAIMERS APPLY:**
    - THE 12XX COOLER CENTERLINE MAY NOT MATCH THE OLD COOLER'S CENTERLINE, SINCE THE 12XX COOLER DRAIN MUST BE 2 5/8" OFF OF CENTER. THIS MAY AFFECT ADA COMPLIANCE.
    - FOR HI-LO COOLER RETROFITS, EXISTING RIGHT-SIDE COOLER MUST BE THE LOW COOLER. DRAIN, WATER, AND ELECTRIC SERVICES MUST BE POSITIONED BEHIND RIGHT-SIDE UNIT.
    - THERE MUST BE WALL BLOCKING OR OTHER STRUCTURAL MATERIAL BEHIND HAWS MOUNTING HOLES.
    - VERIFY THAT DRAIN, ELECTRIC, & WATER SERVICES ARE LOCATED WITHIN BOUNDARIES SPECIFIED ON THIS SHEET AND THE NEXT. SOME RETROFITS MAY REQUIRE THE ELECTRIC OUTLET TO BE MOVED.
  - 4** THE P-TRAP IS NOT SUPPLIED. THE VERTICAL DIMENSIONS GIVEN ARE BASED UPON INSTALLATION USING OF A KEENEY 200W P-TRAP, AND SHOULD THEREFORE BE REGARDED AS REFERENCE-ONLY.
  - 5** THE CENTERLINE OF THE DRAIN STUB-OUT MUST BE BETWEEN 3" [76mm] & 4-5/8" [118mm] OR BETWEEN 6" [152mm] & 8-3/4" [222mm] BELOW THE LOWERMOST EWC MOUNTING BRACKET HOLES IN ORDER FOR THE P-TRAP TO AFFIX PROPERLY TO THE DRAIN TAILPIECE.
    - DEPENDING ON STUB-OUT HEIGHT, SOME TRIMMING OF THE TAILPIECE WILL BE REQUIRED.
    - MOUNTING THE STUB-OUT IN THE HIGHER RANGE WILL REQUIRE TRIMMING THE TAILPIECE ABOVE THE LOWER DRAIN HOSE BRANCH. **IN THIS INSTANCE, THEREFORE, A HI-LO COOLER CANNOT BE INSTALLED.**
  - 6** WHATEVER P-TRAP AND STUB-OUT PLUMBING ARE USED, CARE SHOULD BE TAKEN TO ENSURE THAT THE P-TRAP CAN SEAL TO THE STUB-OUT PROPERLY AND STILL ALIGN TO THE DRAIN TAILPIECE (LOCATED AT THE GIVEN DIMENSIONS).

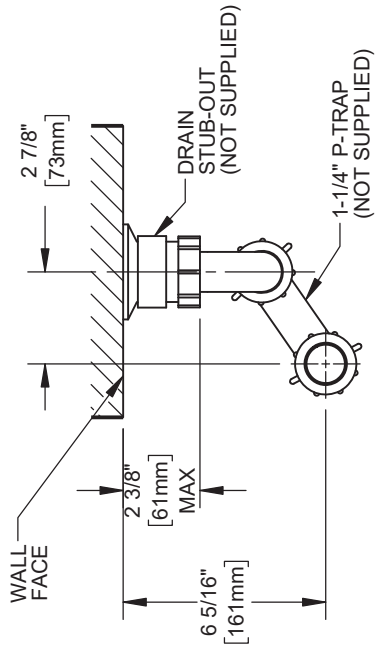

## DRAIN STUB-OUT/P-TRAP DETAIL (VIEWED FROM TOP)

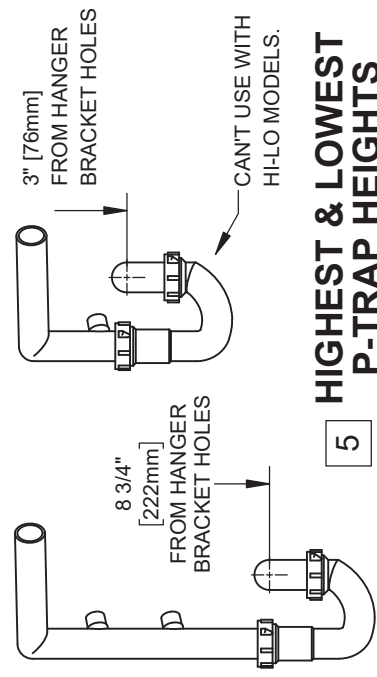

## HIGHEST & LOWEST P-TRAP HEIGHTS



1455 KLEPPE LANE  
SPARKS, NEVADA 89431  
(775) 359-4712 FAX (775) 359-7424  
E-MAIL: HAWS@HAWS.CO.COM  
WEBSITE: WWW.HAWS.CO.COM

ECN: 3543	REV. ECN: BY: MODEL(S)	12XX ELECTRIC WATER COOLERS	PART NUMBER	0510000866.D
DRAWING: DATE: 09/28/20	DHP: 5995	SCALE: 1:8	INSTALLATION	SIZE: A
APPROVED: DATE: 09/28/20	CRD: 5995	DRAWING TYPE	REVISION	6
TM				SHEET 5 OF 7

# RETROFIT INSTALLATION DETAILS

THIS DOCUMENT IS TRUE AND CORRECT AT TIME OF PUBLICATION. CONTINUED PRODUCT IMPROVEMENTS MAKE SPECIFICATIONS AND MEASUREMENTS SUBJECT TO CHANGE WITHOUT NOTICE.

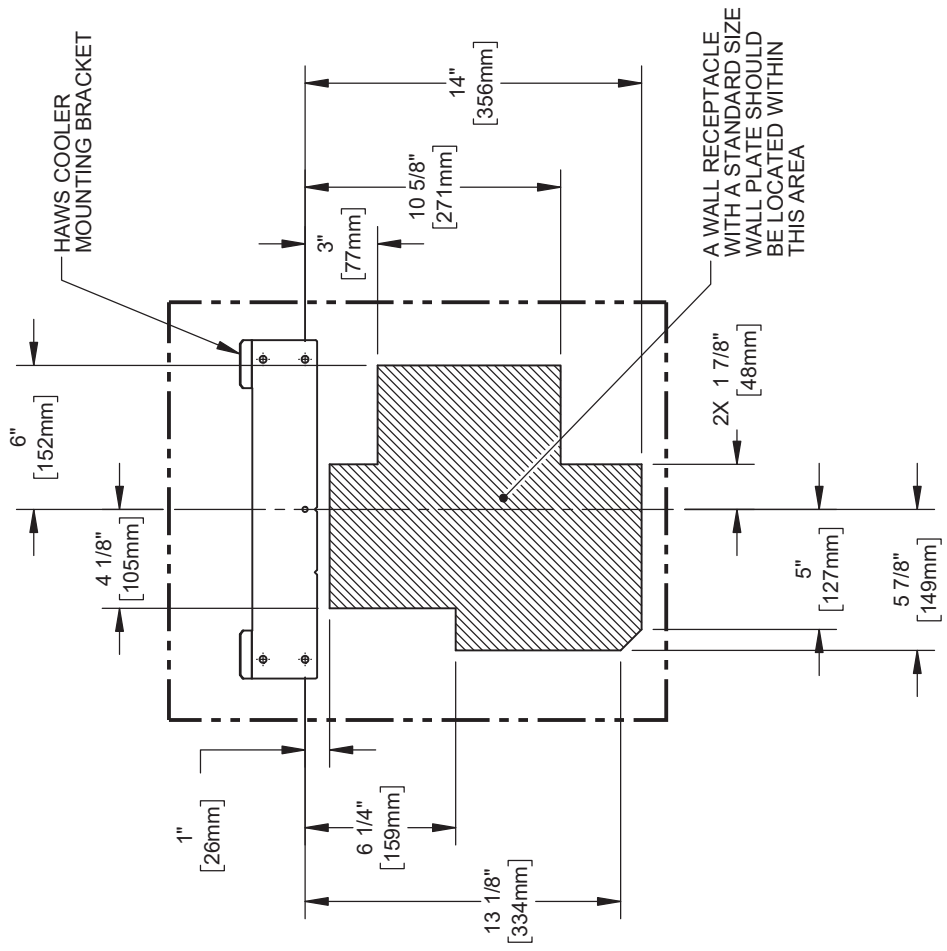
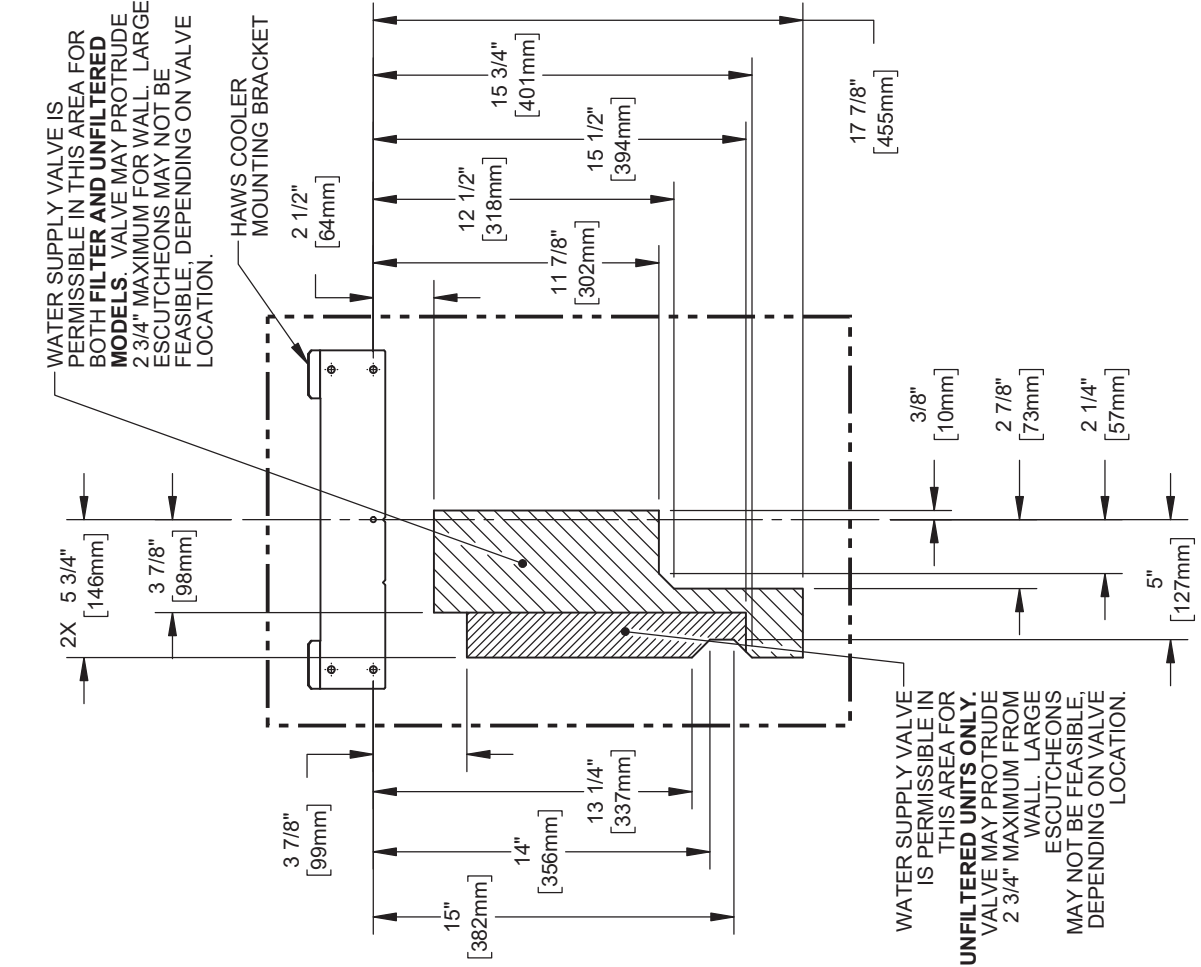

# PERMISSIBLE ELECTRICAL RECEPTACLE LOCATIONS



1455 KLEPPE LANE  
SPARKS, NEVADA 89431  
(775) 359-4712 FAX (775) 359-7424  
E-MAIL: HAWS@HAWS.CO.COM  
WEBSITE: WWW.HAWS.CO.COM

ECN: 5343	REV. EON: 5995	BY: DHP	MODEL(S): 12XX ELECTRIC WATER COOLERS	PART NUMBER: 0510000866.D
DRAWN: 07/15/18	DATE: 09/28/20	CHKD: DHP	INSTALLATION: A	REVISION: 6
APPROVED: [Signature]	TM	SCALE: 1:8	DRAWING TYPE: INSTALLATION	SIZE: A
				SHEET 6 OF 7

# PERMISSIBLE WATER SUPPLY LOCATIONS

© 2020 Haws Corporation - All Rights Reserved. HAWS® and other trademarks used in these materials are the exclusive property of Haws Corporation.

# MAINTENANCE

THIS DOCUMENT IS TRUE AND CORRECT AT TIME OF PUBLICATION. CONTINUED PRODUCT IMPROVEMENTS MAKE SPECIFICATIONS AND MEASUREMENTS SUBJECT TO CHANGE WITHOUT NOTICE.

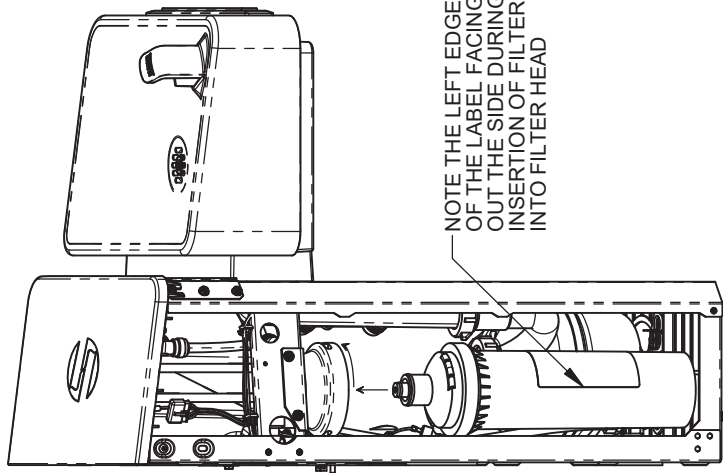

## FILTER REPLACEMENT

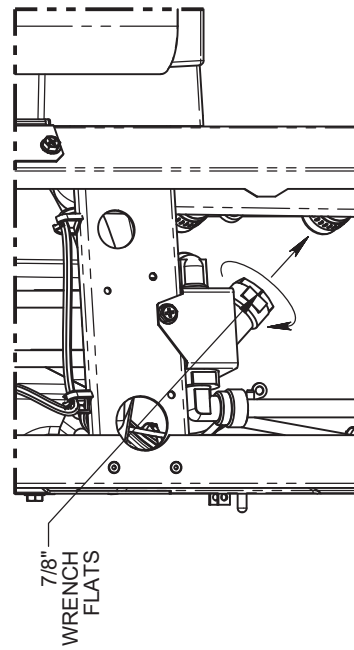

## Y-STRAINER CLEANING

1455 KLEPPE LANE  
 SPARKS, NEVADA 89431  
 (775) 359-4712 FAX (775) 359-7424  
 E-MAIL: HAWS@HAWS.CO.COM  
 WEBSITE: WWW.HAWS.CO.COM



ECN: 5343	REV. ECN: 5343	BY: DHP	DATE: 07/18	CHKD: DHP	DATE: 09/28/20	SCALE: 1:8	DRAWING TYPE: INSTALLATION	SIZE: A	
DRAWN: [Signature]	APPROVED: [Signature]	TM							
MODEL(S): 12XX ELECTRIC WATER COOLERS							PART NUMBER: 0510000866.D	REVISION: 6	SHEET 7 OF 7