



model 3377

Barrier-Free Steel Pedestal Fountain

## FEATURES & BENEFITS

### CONSTRUCTION

Heavy-duty 3/16" (.47 cm) galvanized steel pedestal is supported by an integral mounting plate, supplied with a top down access plate, and is finished with green powder-coat paint. 18 gauge Type 304 Stainless Steel swirl design bowl, 14 gauge Type 304 Stainless Steel bracket, and a vandal-resistant bottom plate provides a long lasting unit with added peace of mind.

### QUALITY CONTROL

Pre-built fountain is pressure tested to ensure no leaks and proper functionality.

### BUBBLER HEAD

Polished chrome-plated brass bubbler head with integral laminar flow prevents splashing while providing a superior flow pattern. The integral basin shank and inserted roll pin add vandal resistance strength. Shielded, angled stream opening provides a steady, sanitary source of drinking water at .45 gpm.

### PUSH BUTTON VALVE

The push-button activated valve assembly allows for front access stream adjustment as well as cartridge and strainer access. The valve works at an operating pressure range of 30 to 90 psi (2.1 to 6.2 bar).

## OPTIONS

- Faucet Valve: Model 6250LF, self-closing, plain end, lead-free, brass bib faucet with polished chrome-plated finish. (When used with Haws concrete products, also order part 0004499489; for 3511, use 0004521763)
- Sand Trap: Model 6611, sand trap for installing adjacent to pedestal drinking fountains to help prevent debris and contaminants from clogging waste line.
- Bottle Filler Attachment: Model 3377BF, bottle filler attachment for the Haws 3377 pedestal fountain utilizes a satin finish stainless steel bracket, 100% lead-free waterways, laminar flow, and painted galvanized steel pedestal extension.

For more information, visit [www.hawsc.com](http://www.hawsc.com) or call (888) 640-4297.



## SPECIFICATIONS

Model 3377 barrier-free pedestal drinking fountain shall include an 18 gauge Type 304 Stainless Steel satin finish basin with integral swirl design, 14 gauge Type 304 Stainless Steel bracket, 100% lead-free waterways, push-button operated stainless steel valve with front-accessible cartridge and flow adjustment, polished chrome-plated brass vandal-resistant bubbler head with integral laminar anti-squirt flow, chrome-plated brass vandal-resistant waste strainer, vandal-resistant bottom plate, 3/16" galvanized steel top-access pedestal with green powder-coated finish, integral mounting plate, and 1-1/4" IPS waste.

## APPLICATIONS

Perfect for either public or private outdoor settings, the 3377 is a great fit in areas where aesthetics are important to the overall appeal of the architecture. Suitable in areas where weather conditions exist, this series stands strong as a nice addition to any community. Powder-coated finish helps to maintain the fountain's overall appeal so it remains looking as new as it did when it was installed. This type of pedestal drinking fountain may also be placed in a variety of settings such as: parks, schools, and other outdoor environments around office buildings where the temperature remains above freezing. Model meets all current Federal Regulations for the disabled including those in the Americans with Disabilities Act. Haws manufactures drinking fountains and electric water coolers to be lead-free by all known definitions including NSF/ANSI Standard 61, Section 9, NSF/ANSI 372, California Proposition 65, and the Federal Safe Drinking Water Act. Product is compliant to California Health and Safety Code 116875 (AB 1953-2006).



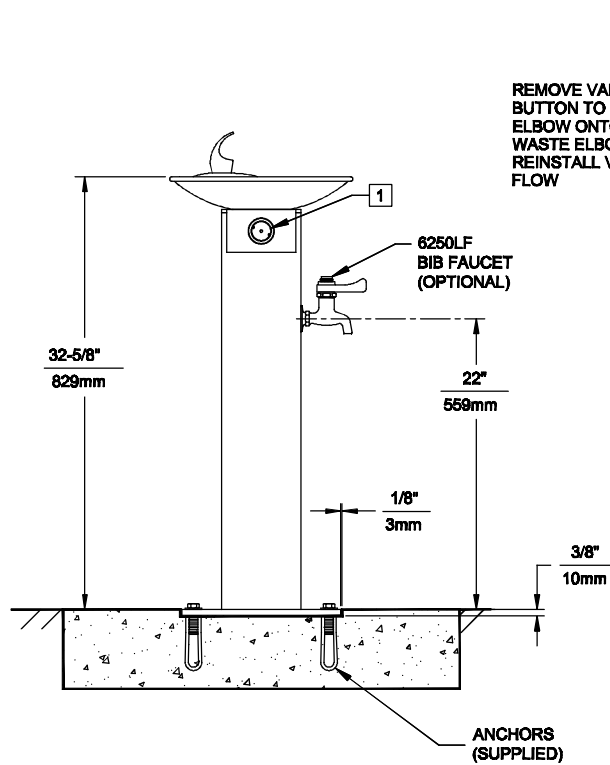
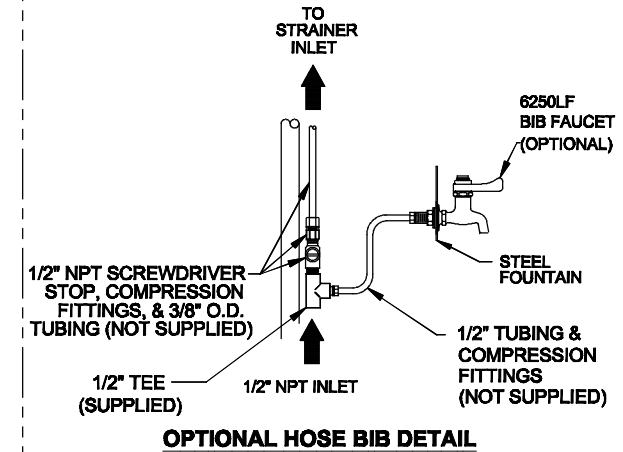
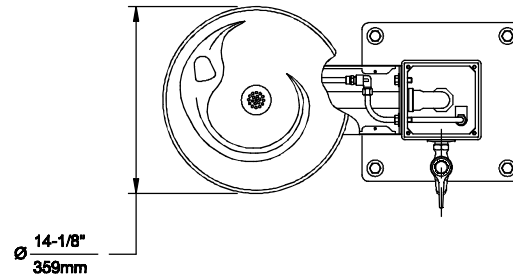
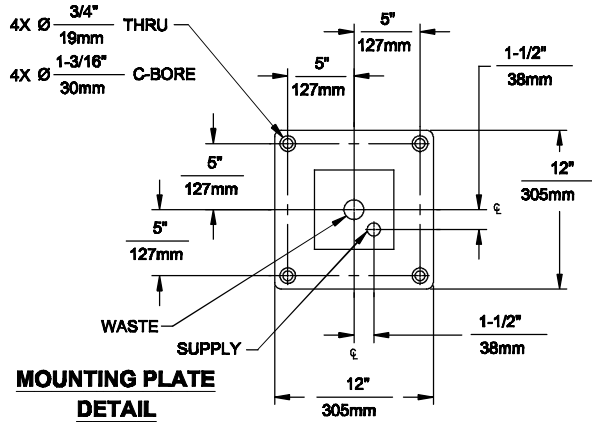

REMOVE VALVE FROM PUSH BUTTON TO INSTALL WASTE ELBOW ONTO BOWL. AFTER WASTE ELBOW IS INSTALLED, REINSTALL VALVE & ADJUST FLOW

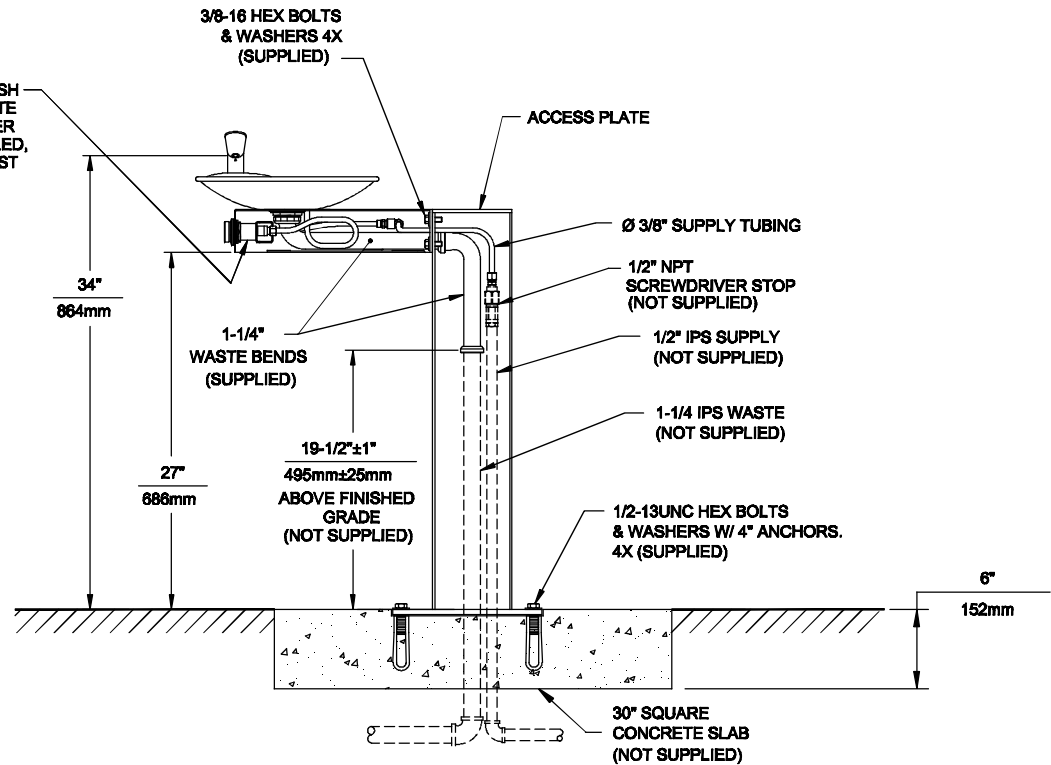

**NOTES:**

- 1 REFER TO 5874SS OPERATION AND MAINTENANCE MANUAL FOR PUSH BUTTON AND VALVE INSTALLATION/MAINTENANCE INSTRUCTIONS.



1455 KLEPPE LANE  
SPARKS, NEVADA 89431  
(775) 359-4712 FAX (775) 359-7424  
E-MAIL: HAWS@HAWSO.COM  
WEBSITE: WWW.HAWSO.COM

ECN NO. REVISED PER BY: ECN: 4828 HM	MODEL(S)	PART NUMBER
DRAWN: RTM DATE: 05/97 CHKD.:	3377/3377G	0002077364.D
APPROVED: DATE:	SCALE: 1:16 DRAWING TYPE: INSTALLATION	DRAWING NO. REV 13066A00 12
	SIZE: A	SHEET 1 OF 1