

FEATURES & BENEFITS

OPTIONS

For more information, visit www.hawesco.com or call (888) 640-4297.



SPECIFICATIONS

The Haws 6468 drip tray is made of 304 Stainless Steel is used as a retrofit accessory for the Haws 1920 bottle filler. Easy mounting instructions allow the bottle filling station to work with this tray and bracket drain.

APPLICATIONS

NOTES:

- 1 ASSEMBLE DRAIN WITH NUT AND WASHER AS SHOWN. AFTER INSTALLATION, CAREFULLY SEAL WALL AROUND DRAIN.
2. WHEN INSTALLING THIS UNIT, LOCAL, STATE, OR FEDERAL CODES SHOULD BE ADHERED TO. INSTALL A TRAP IN THE WASTE LINE AND A SCREWDRIVER STOP IN THE SUPPLY LINE IF REQUIRED.
3. OPTIONAL HAWS MOUNTING PLATE MODEL 6700 (NOT SHOWN) MAY BE USED WITH THIS MODEL. OPTIONAL HAWS BACK PANEL MODEL BP6 (NOT SHOWN) MAY BE USED WITH THIS MODEL. SEE SEPARATE INSTALLATION DRAWINGS FOR MOUNTING PLATE OR BACK PANEL INSTALLATION IF REQUIRED.
5. 3/8" DIAMETER BOLTS OR SCREWS (NOT SUPPLIED) ARE RECOMMENDED.

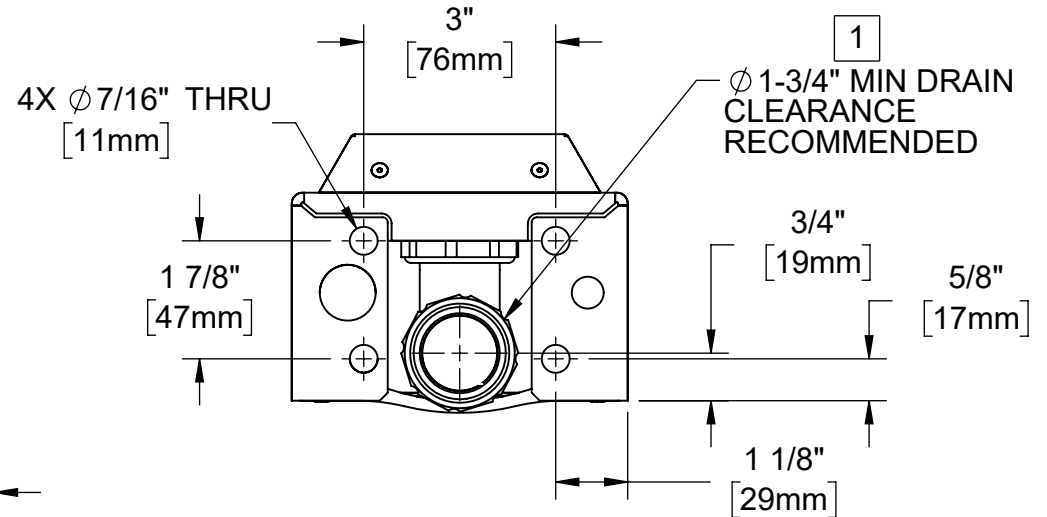
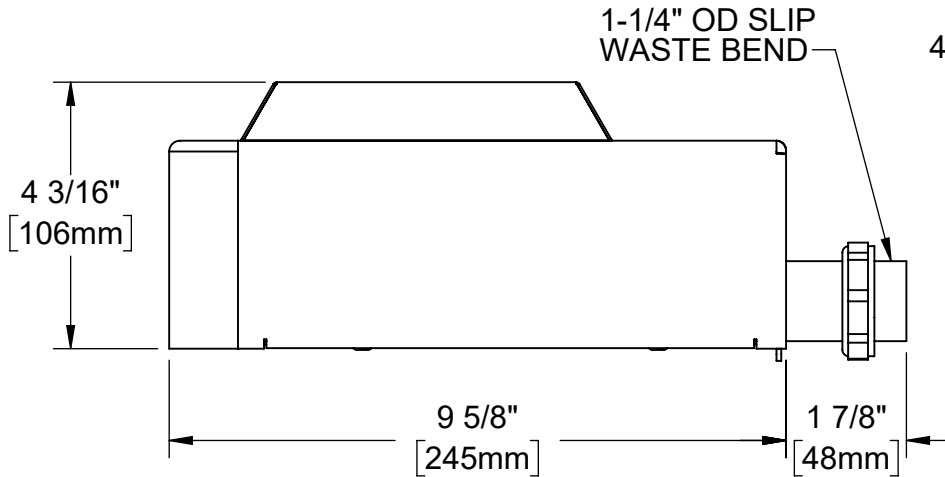
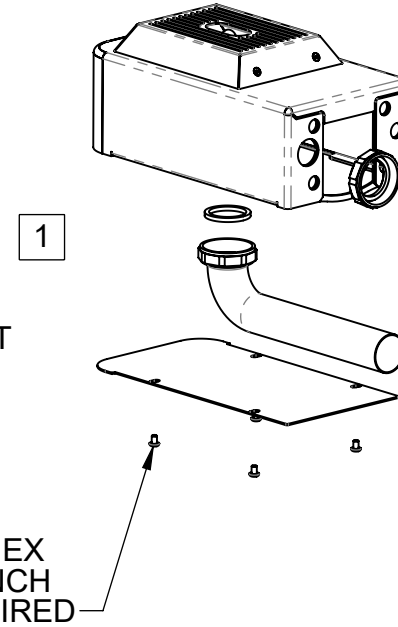
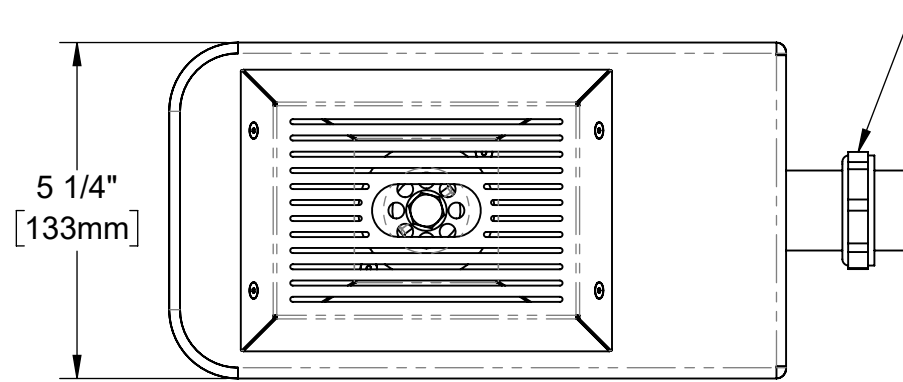

		1455 KLEPPE LANE SPARKS, NEVADA 89431 (775) 359-4712 FAX (775) 359-7424 E-MAIL: HAWS@HAWSO.COM WEBSITE: WWW.HAWSO.COM	
		ECN: 5607 REV. ECN: 5667 DRAWN: DP APPROVED: DP	BY: DP DATE: 10/28/20 DATE: 02/22/21
SCALE: 14		DRAWING TYPE: INSTALLATION	SIZE: A SHEET 1 OF 1