



# INSTALLATION, OPERATION & MAINTENANCE INSTRUCTIONS

1455 Kleppe Lane ♦ Sparks, NV 89431-6467 ♦ (775) 359-4712 ♦ Fax (775) 359-7424  
E-mail: [haws@hawsco.com](mailto:haws@hawsco.com) ♦ website: [www.hawsco.com](http://www.hawsco.com)

No. 0510002058 (3)

## MODELS 7660 & 7661 Eye/Face Wash and Handwash Station

**CAUTION:** This product is not NSF-61 certified and should not be used for drinking water.  
**NOTE TO INSTALLER:** Please leave this information with the Maintenance Department.

### LIMITED WARRANTY

*HAWS* warrants that all of its products are guaranteed against defective material or poor workmanship for a period of **one year from the date of shipment**. The foregoing notwithstanding, *HAWS* warrants certain specific products or components thereof for an adjusted period. A list of these excepted products and components and a description of their respective warranty terms may be found here: [www.hawsco.com/warranty](http://www.hawsco.com/warranty). *HAWS'* liability under this warranty shall be discharged by furnishing without charge F.O.B. *HAWS* factory any goods, or part thereof, which shall appear to the Company upon inspection to be of defective material or not of first-class workmanship, provided that a claim is made in writing to Company within a reasonable period after receipt of the product. Where claims for defects are made, the defective part or parts shall be delivered to the Company, prepaid, for inspection. *HAWS* shall not be liable for the cost of repairs, alterations or replacements, or the labor required to implement them, or for any expense connected therewith made by the owner or owner's agents, except upon written authority from *HAWS*. *HAWS* shall not be liable for any damages caused by defective materials or poor workmanship, except for replacements, as provided above. Buyer agrees that *HAWS* has made no other warranties either express or implied in addition to those above stated, except that of title with respect to any of the products or equipment sold hereunder and that *HAWS* shall not be liable for general, special, incidental, or consequential damages claimed to arise under the contract of sale.

Equipment manufactured by *HAWS* is warranted to function if installation and maintenance instructions provided are adhered to. The units also must be used for the purpose for which they were intended. Any *HAWS* emergency equipment is intended to supplement first-aid treatment. Due to widely varying conditions, *HAWS* cannot guarantee that the use of this emergency equipment will prevent serious injury or the aggravation of existing or prior injuries.

**EXCEPT AS EXPRESSLY STATED HEREIN, HAWS HEREBY DISCLAIMS ALL WARRANTIES, WHETHER EXPRESS OR IMPLIED, ARISING BY LAW OR OTHERWISE, INCLUDING WITHOUT LIMITATION, ANY IMPLIED WARRANTIES OF MERCHANTABILITY AND FITNESS FOR A PARTICULAR PURPOSE. THIS WARRANTY MAY NOT BE MODIFIED OR EXTENDED WITHOUT THE WRITTEN CONSENT OF HAWS. REMEDIES AND REPLACEMENTS STATED HEREIN ARE EXCLUSIVE. IN NO EVENT SHALL HAWS BE LIABLE FOR ANY SPECIAL, PUNITIVE, CONSEQUENTIAL OR INCIDENTAL DAMAGES TO ANY PERSON INCLUDING BUT NOT LIMITED TO DAMAGES FOR LOSS OF USE OR PROFITS, SUBSTITUTE PRODUCTS OR COSTS, PROPERTY DAMAGE. OR OTHER MONETARY LOSS.**

**SHOULD YOU EXPERIENCE DIFFICULTY WITH THE INSTALLATION OF THIS MODEL PLEASE CALL:**

**TECHNICAL SUPPORT: 1-800-766-5612**  
**FOR CUSTOMER SERVICE: 1-888-640-4297**

**RECOMMENDED TOOLS & PARTS:**

- Measuring Tape
- Pencil and Permanent Marker
- Level
- Power Drill
- 1/4" Bit-Holding Screwdriver
- Extension driver for 1/4" bit, at least 3"
- #3 Phillips Bit (Supplied)
- Plastic Tubing Cutter
- Adjustable Tongue & Groove Pliers
- 7/8", 7/16", and 13/16" Box/Open Combination Wrenches
- 1/4" Structural screws for wall materials

**LOCATION OF UNIT:** The Models 7660 & 7661 are designed to be ADA compliant when installed with the sink rim height at 33 5/8" and an unobstructed floor space of at least 38" wide centered on unit and 51" in depth from the wall. Refer to USP <800> when installing these models in a lab designed for compounding hazardous drugs. When installing this unit, local, state and federal (including ADA) codes must be adhered to.

**SUPPLY LINE:** The minimum recommended line size is 1/2" IPS with 30-90 psi (2-6 ATM) flowing pressure for both hot and cold-water lines. The Operating Water Supply Temperature Range for Models 7660 & 7661 is 120° F - 180° F (49° C – 82° C) Hot and 40° F - 65° F (4° C – 18.3° C) Cold. If a failure occurs and hot water pressure is lost, 50-90psi (3.4-6 ATM) flowing pressure is required for the cold-water line.

**PLUMBING CONNECTIONS:** 1/2" O.D. compression stop valves must be installed at the wall (by others). Use the supplied Brass inserts and plastic ferrules when connecting the 3/8" PEX (1/2" O.D.) tubing to 1/2" O.D. compression fittings. Waste outlet is 1-1/2" OD Slip-Joint. Please consult the installation drawings below for details on the supply and waste fitting connections.

**MAINTENANCE:** Periodically clean the two brass strainers located under the sink. If the faucet is operated in battery mode, a low battery is indicated by a single LED flash at the faucet sensor approximately every 2 seconds. Battery replacement requires 4 AA Batteries and access to the faucet control module located under the sink. Refer to the Operation and Maintenance Manual for Haws Models 9201EW and 7610S for more information on the thermostatic mixing valve and Eye/Face Wash respectively. Refer to the included faucet manual for more information on the settings and operation of the faucet.

## INSTALLATION PROCEDURE (PAGES 2, 4-10)

### GENERAL NOTES:

1. The following assembly instructions must be followed to ensure a watertight connection at the stop valves and other PEX connections:
  - a. Cut tubing square and clean. Deburr if necessary.
  - b. Place compression nut and supplied plastic ferrule over end of tubing and install the supplied tubing insert into end of tubing.
  - c. Push tube into the fitting until it bottoms out.
  - d. Thread the nut down onto the supply valve until finger tight. Put a line on the nut using a marker. Tighten exactly one additional full (360 degrees) turn with a wrench, using the line to count turns.
2. Do not over-torque the screws when installing the front cover.
3. If installing with in-wall carrier (Haws model 6800/6810 and mounting plate 6776), refer to installation instructions included with those models.
4. This product is not intended for lavatory or residential use.

\*For more information about Haws products, see our website: [www.hawSCO.com](http://www.hawSCO.com)

THIS DOCUMENT IS TRUE AND CORRECT AT TIME OF PUBLICATION. CONTINUED PRODUCT IMPROVEMENTS MAKE SPECIFICATIONS AND MEASUREMENTS SUBJECT TO CHANGE WITHOUT NOTICE.

ITEM	DESCRIPTION	PART NO.
1	THERMOSTATIC MIXING VALVE	9201EW
2	9201EW COMPLETE REPAIR KIT (SEE 9201EW PARTS BREAKDOWN FOR DETAILS)	VRK01EW.A
3	9201EW BASIC MAINT KIT W/ T-STAT+O-RINGS (SEE 9201EW PARTS BREAKDOWN FOR DETAILS)	VRK01EW.E
4	EYE/FACE WASH VALVE REPAIR KIT	VRK7650
5	EYE/FACE WASH COVER	9091
6	AXION EYE/FACE WASH HEAD (COVER INCLUDED)	SP65PD
7	PULLDOWN EYE/FACE WASH LABEL	0003163821.10
8	EYE/FACE WASH SIGN	SP175
9	0.5 GPM LAMINAR FLOW CONTROL	0110001497
	1.2 GPM LAMINAR FLOW CONTROL	0110001498
	2.2 GPM LAMINAR FLOW CONTROL (NOT AVAILABLE IN ALL LOCATIONS)	0110001499

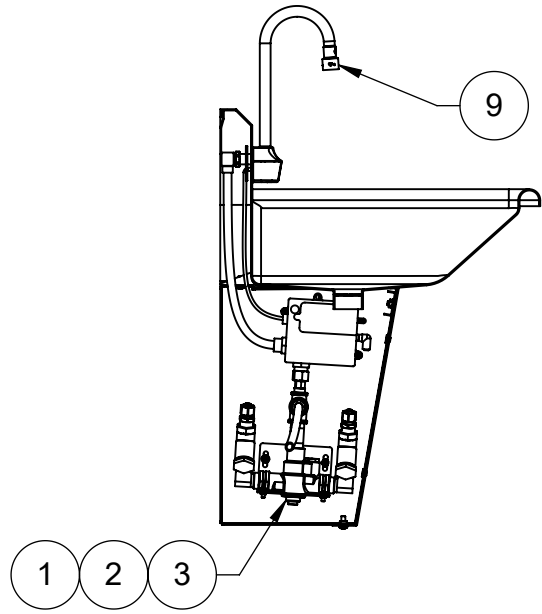
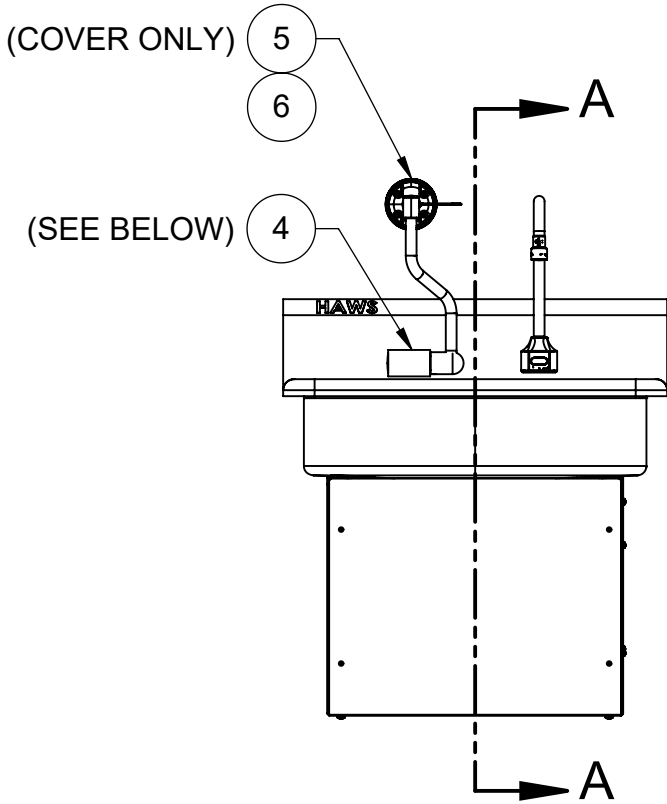

**SECTION A-A**

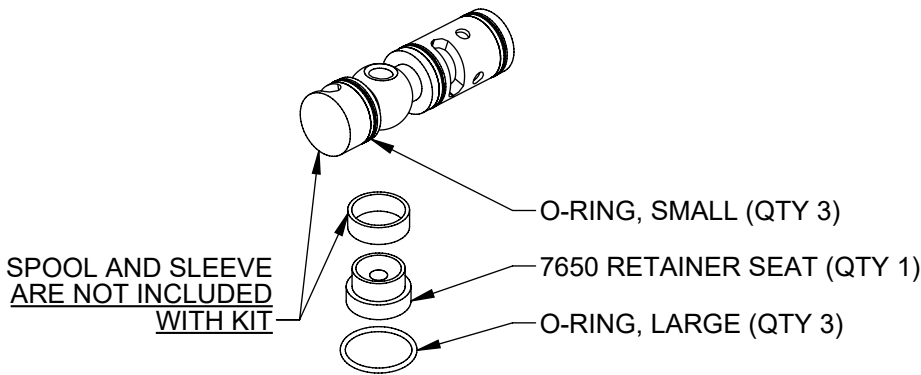

**4 VRK7650 REPAIR KIT**

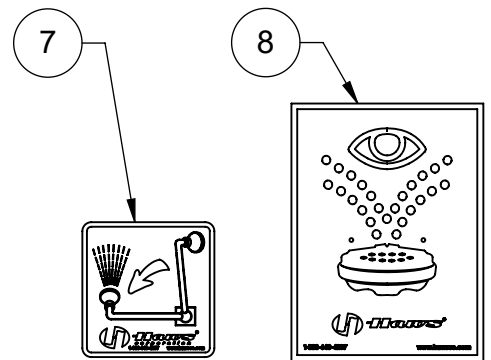

**SIGNAGE**

				1455 KLEPPE LANE SPARKS, NEVADA 89431 (775) 359-4712 FAX (775) 359-7424 E-MAIL: HAWS@HAWSO.COM WEBSITE: WWW.HAWSO.COM	
ECN: 5858	REV. ECN: 5902	BY: FV	MODEL(S)	PART NUMBER	
DRAWN: DHP	DATE: 03/25/22	CHKD: JU	7660 & 7661	0510002058	
APPROVED: JL	DATE: 06/01/23	SCALE: 1:12	DRAWING TYPE: PARTS BREAKDOWN	REVISION	3
			SIZE: A	SHEET 1 OF 1	

**WHEN ORDERING PARTS, PLEASE SPECIFY PART NUMBER**

NOTES:

1. WHEN INSTALLING THIS UNIT, LOCAL, STATE, OR FEDERAL CODES SHOULD BE ADHERED TO FOR INSTALLATIONS (LOCATIONS), WASTE AND SUPPLY REQUIREMENTS OTHER THAN SHOWN.
2. HOLD PLUMBING & ELECTRICAL DIMENSIONS  $\pm 1/4"$  [6.4MM]. HOLD MOUNTING DIMENSIONS  $\pm 1/8"$  [3.2MM].

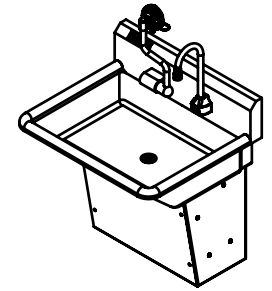
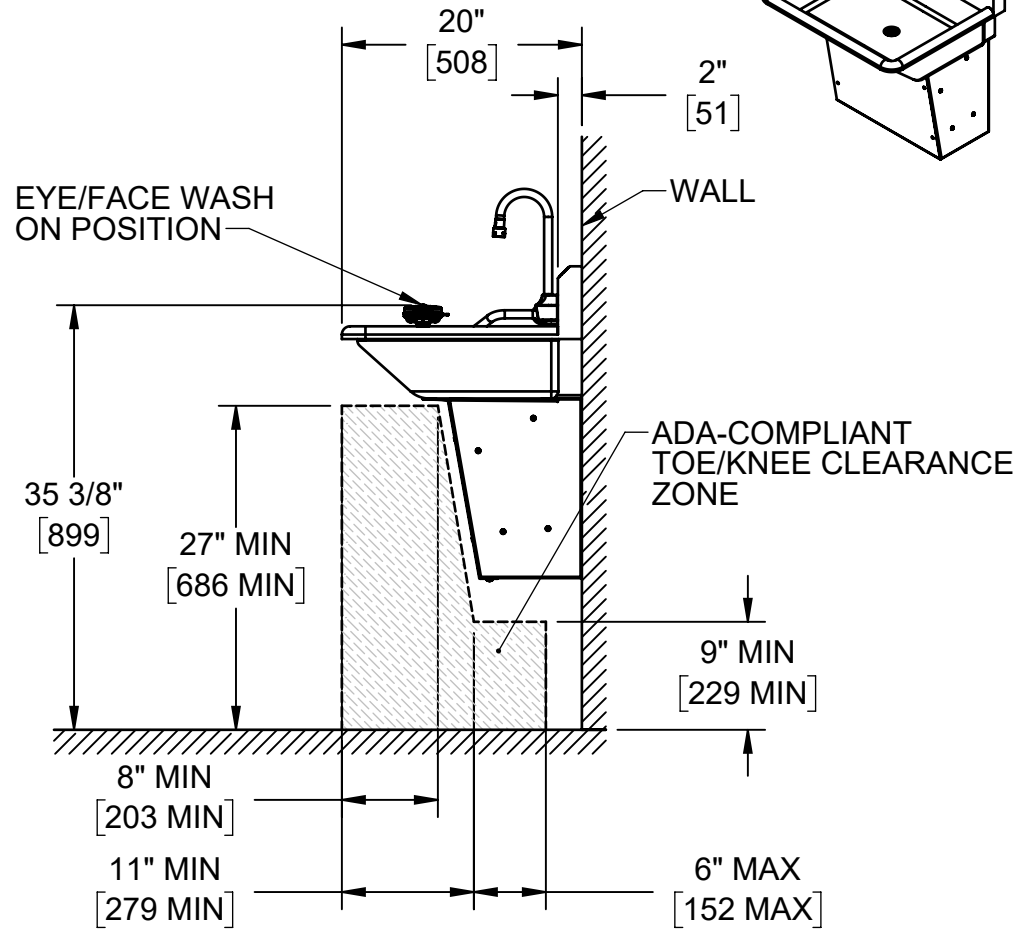
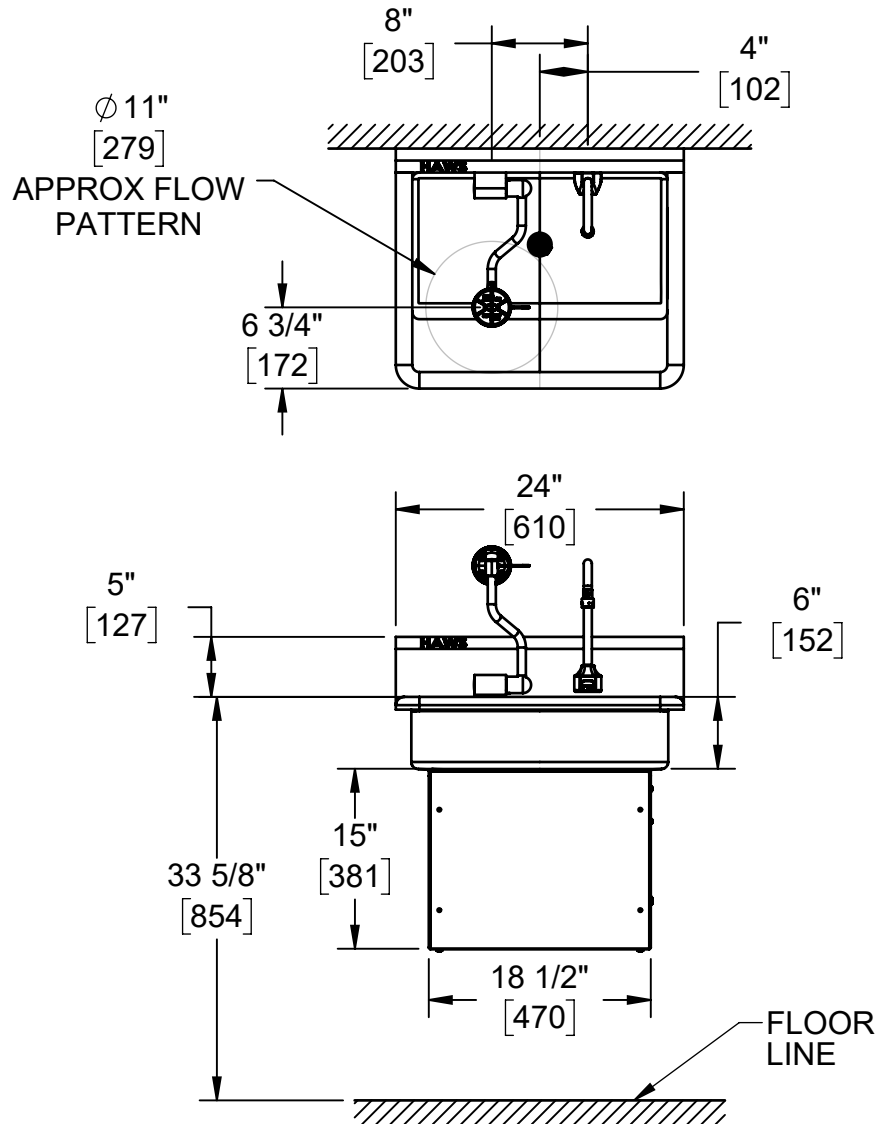

**HAWS MODEL 7660  
24" WIDE SINK**

		1455 KLEPPE LANE SPARKS, NEVADA 89431 (775) 359-4712 FAX (775) 359-7424 E-MAIL: HAWS@HAWS.CO.COM WEBSITE: WWW.HAWS.CO.COM	
		ECN: 5806 REV. ECN: 5902 DRAWN: DHP APPROVED: DHP	BY: FV CHKD: JU DATE: 03/25/23 DATE: 05/26/23
SCALE: 1:16		DRAWING TYPE: INSTALLATION	
SIZE: A		SHEET 1 OF 7	

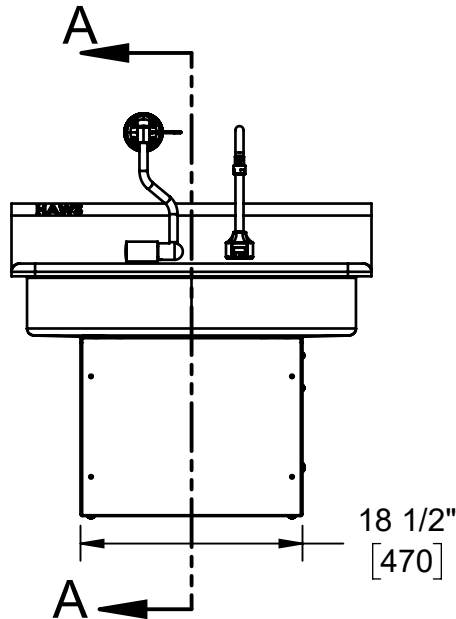
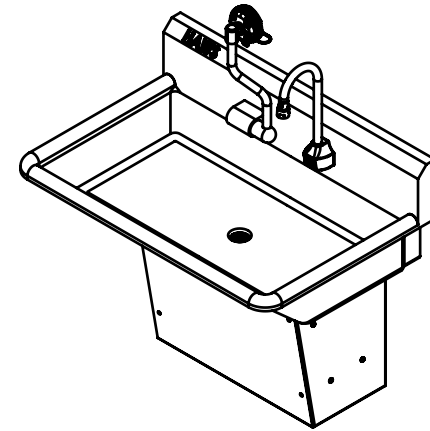
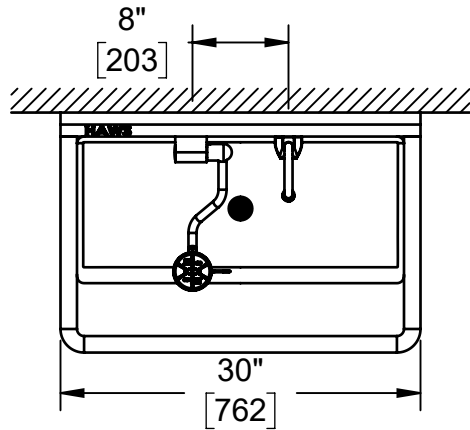

EYE/FACE WASH OFF POSITION

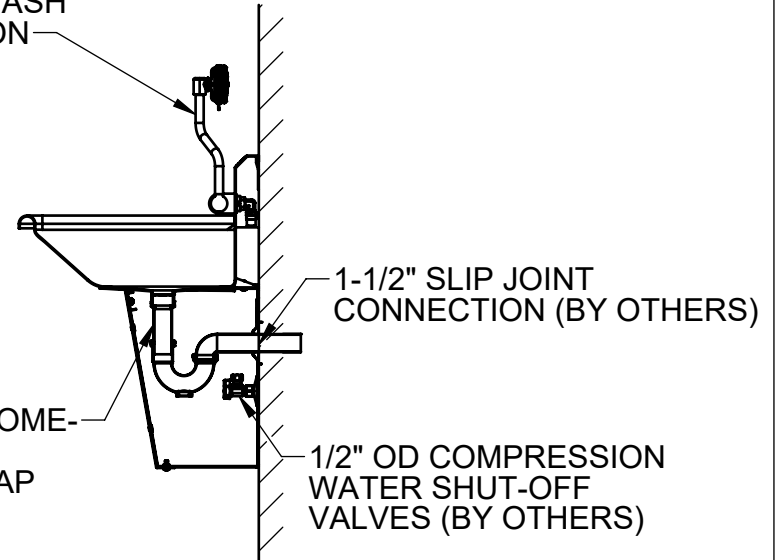

1-1/2" DRAIN: CHROME-PLATED BRASS TAILPIECE & P-TRAP (SUPPLIED)

1-1/2" SLIP JOINT CONNECTION (BY OTHERS)

1/2" OD COMPRESSION WATER SHUT-OFF VALVES (BY OTHERS)

SECTION A-A

**HAWS MODEL 7661  
30" WIDE SINK**



1455 KLEPPE LANE  
SPARKS, NEVADA 89431  
(775) 359-4712 FAX (775) 359-7424  
E-MAIL: HAWS@HAWSO.COM  
WEBSITE: WWW.HAWSO.COM

ECN: 5806	REV. ECN: 5902	BY: FV	MODEL(S) 7660 & 7661	PART NUMBER 0510002058.D
DRAWN: DHP	DATE: 03/25/22	CHKD: JU	EYE/FACE WASH AND HANDWASH STATION	REVISION 3
APPROVED: DHP	DATE: 05/26/23	SCALE: 1:16	DRAWING TYPE: INSTALLATION	SHEET 2 OF 7

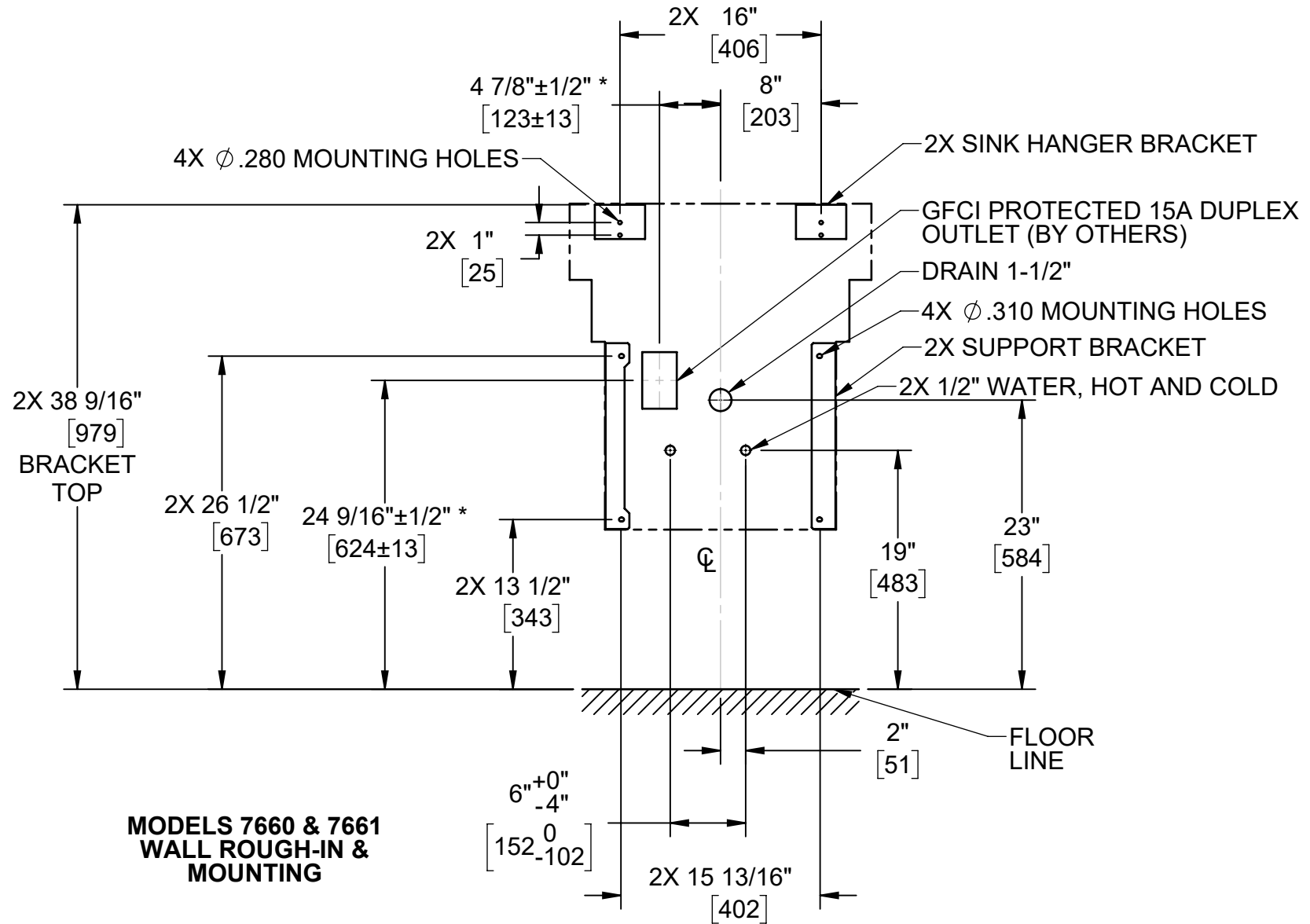

\*IF INSTALLING WITH HAWS MODEL 6800/6810 IN-WALL CARRIER WITH 6776 MOUNTING PLATE, REFER TO INSTALLATION INSTRUCTIONS INCLUDED WITH THOSE MODELS FOR PLACEMENT OF ELECTRICAL BOX.

		1455 KLEPPE LANE SPARKS, NEVADA 89431 (775) 359-4712 FAX (775) 359-7424 E-MAIL: HAWS@HAWS.CO.COM WEBSITE: WWW.HAWS.CO.COM			
		ECN: 5806	REV. ECN: 5902	BY: FV	MODEL(S) 7660 & 7661
DRAWN: DHP	DATE: 03/25/22	CHKD: JU	EYE/FACE WASH AND HANDWASH STATION		REVISION 3
APPROVED: DHP	DATE: 05/26/23	SCALE: 1:12	DRAWING TYPE: INSTALLATION	SIZE: A	SHEET 3 OF 7

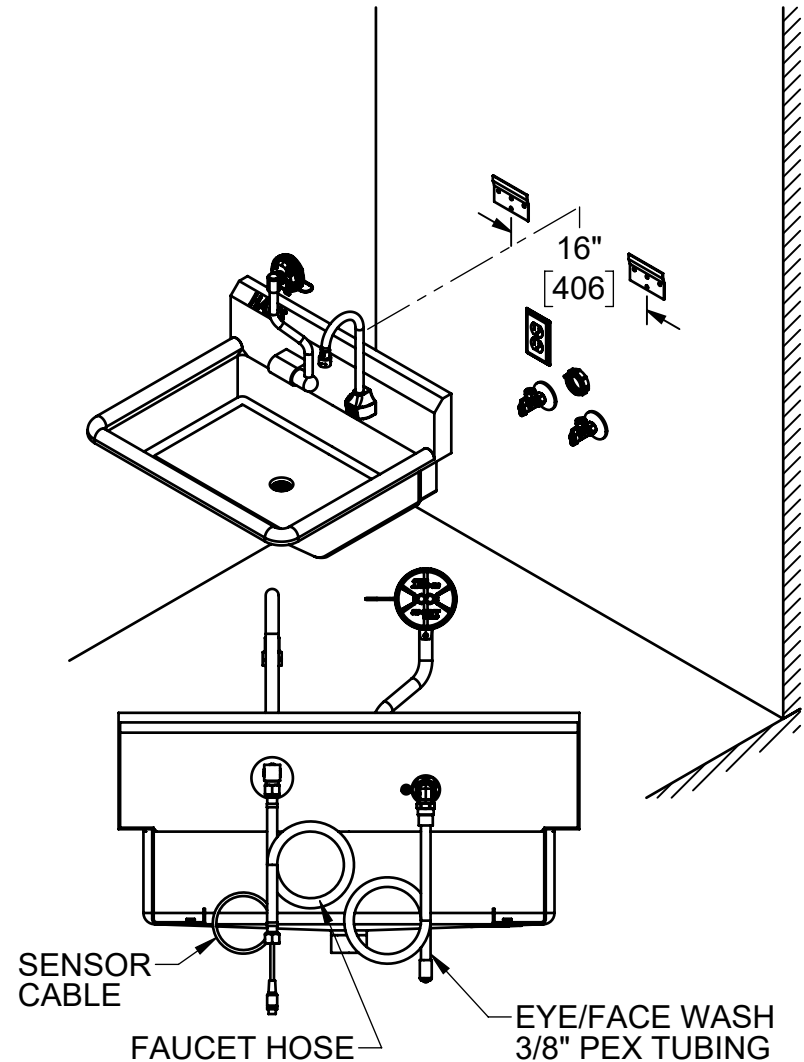
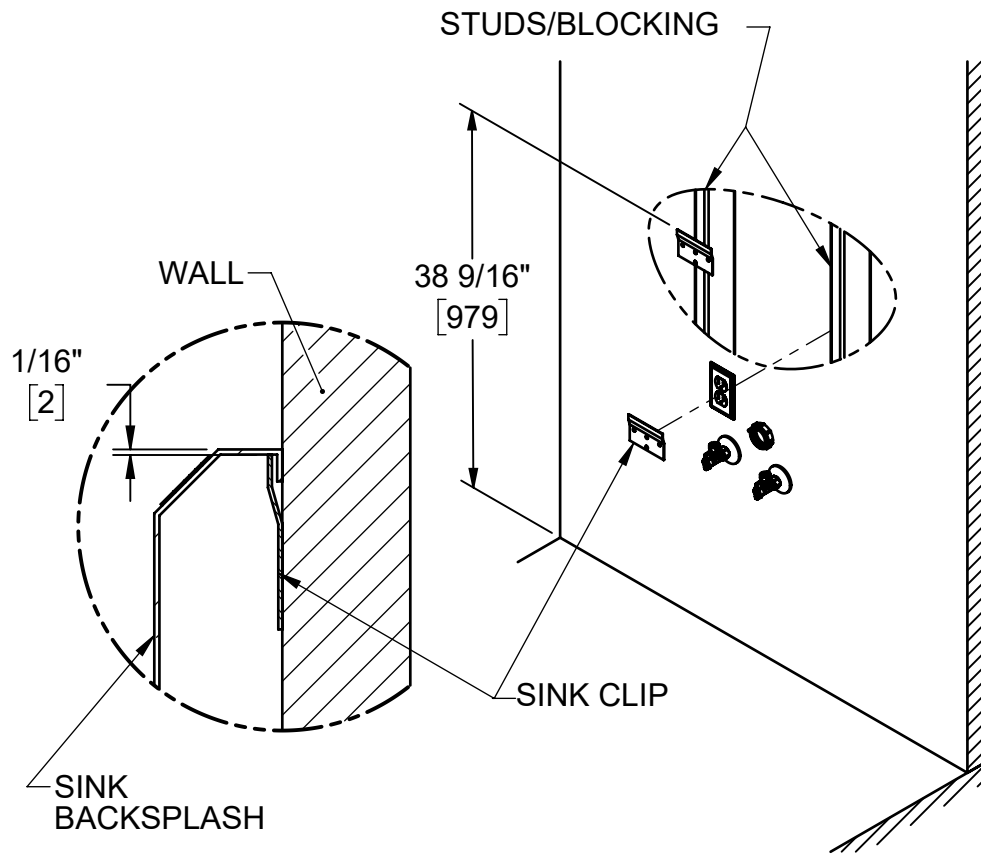

**STEP 1**  
 VERIFY DRAIN AND WATER SUPPLY CONNECTIONS HAVE BEEN INSTALLED/LOCATED CORRECTLY. INSTALL THE SINK CLIPS AT A WALL STUD OR STRUCTURAL BRACING 1/16" LOWER THAN THE TOP OF THE SINK HEIGHT USING STRUCTURAL SCREWS. ENSURE THE SINK CLIPS ARE MOUNTED LEVEL RELATIVE TO EACH OTHER AND ARE 16" APART CENTER TO CENTER.

**NOTE:** IT IS RECOMMENDED THAT THE SINK BE MOUNTED TO A WATERPROOF WALL SURFACE THAT EXTENDS 18" IN ALL DIRECTIONS FROM OUTLINE OF SINK ON WALL.

**STEP 2**  
 MARK A LINE CENTERED BETWEEN THE STUDS/BLOCKING FROM 13" TO 27.5" ABOVE THE FINISH FLOOR LINE. UNCOIL THE SENSOR CABLE AND HOSES AT THE BACK OF THE SINK AND HANG THE SINK FROM THE CLIPS. ALIGN THE CENTER OF THE SINK/DRAIN WITH THIS CENTERLINE.

				1455 KLEPPE LANE SPARKS, NEVADA 89431 (775) 359-4712 FAX (775) 359-7424 E-MAIL: HAWS@HAWS.CO.COM WEBSITE: WWW.HAWS.CO.COM	
				ECN: 5806 DRAWN: DHP APPROVED: DHP	REV. ECN: 5902 DATE: 03/25/22 DATE: 05/26/23
SCALE: 1:16		DRAWING TYPE: INSTALLATION		SIZE: A	

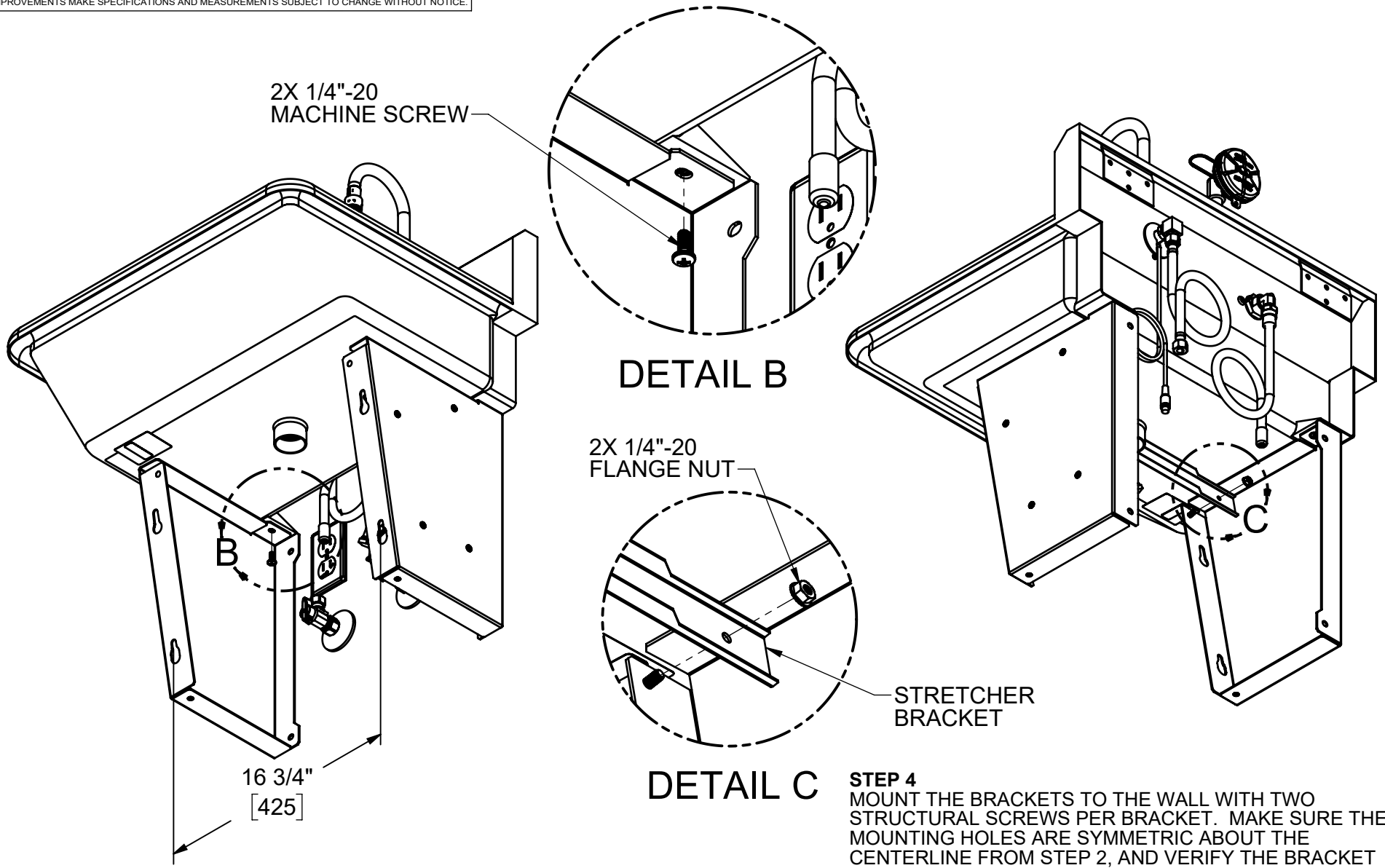

2X 1/4"-20  
MACHINE SCREW

DETAIL B

2X 1/4"-20  
FLANGE NUT

DETAIL C

STRETCHER  
BRACKET

16 3/4"  
[425]

**STEP 4**  
MOUNT THE BRACKETS TO THE WALL WITH TWO STRUCTURAL SCREWS PER BRACKET. MAKE SURE THE MOUNTING HOLES ARE SYMMETRIC ABOUT THE CENTERLINE FROM STEP 2, AND VERIFY THE BRACKET SIDES ARE VERTICAL. BRACKET MOUNTING HOLES ARE SPACED SLIGHTLY LESS THAN 16" TO ALLOW FOR ANGLED SCREW INSTALLATION WITH 16" STUD SPACING.

**STEP 3**  
HANG THE LEFT AND RIGHT BRACKETS FROM THE SINK BY INSTALLING A 1/4"-20 MACHINE SCREW (SUPPLIED) THROUGH EACH BRACKET FROM UNDERNEATH THE SINK. INSTALL THE STRETCHER BRACKET USING TWO 1/4"-20 FLANGE NUTS (SUPPLIED).

		1455 KLEPPE LANE SPARKS, NEVADA 89431 (775) 359-4712 FAX (775) 359-7424 E-MAIL: HAWS@HAWSO.COM WEBSITE: WWW.HAWSO.COM	
		ECN: 5806 DRAWN: DHP APPROVED: DHP	REV. ECN: 5902 DATE: 03/25/23 DATE: 05/26/23
PART NUMBER 0510002058.D			REVISION 3
SCALE: 1:8   DRAWING TYPE: INSTALLATION   SIZE: A		SHEET 5 OF 7	



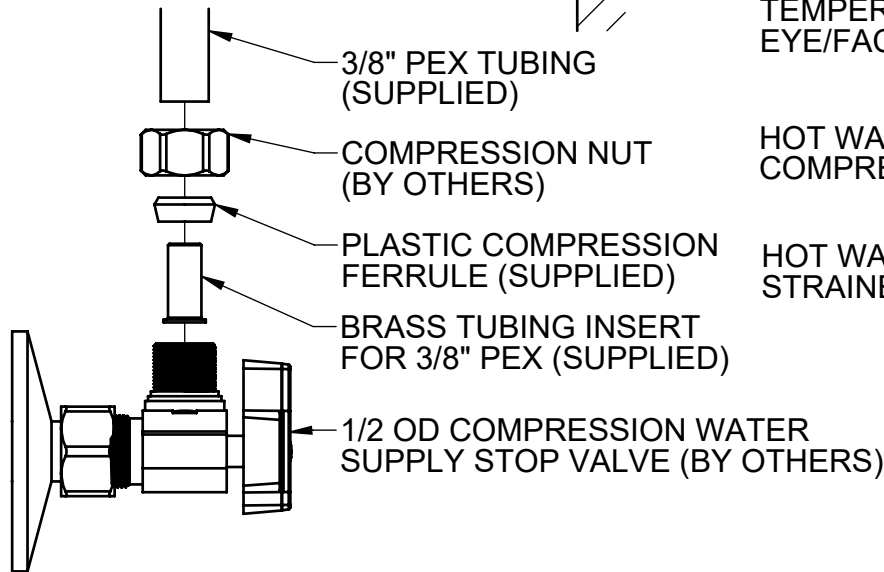
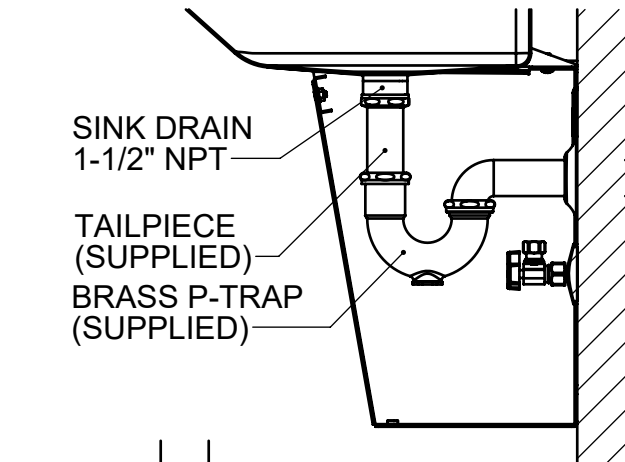

**STEP 5**  
 CUT THE SUPPLIED 3/8" PEX INLET LINES SQUARE AND CLEAN TO THE APPROPRIATE LENGTH, IF NEEDED. INSTALL THE COMPRESSION NUT (INCLUDED WITH THE SUPPLY VALVE BY OTHERS), FOLLOWED BY THE PLASTIC FERRULE (SUPPLIED), AND THE BRASS TUBE INSERT (SUPPLIED) ONTO THE INLET LINE. NOTE THE CORRECT ORIENTATION OF THE PLASTIC FERRULE, AS SHOWN ABOVE. DO NOT USE THE BRASS FERRULE INCLUDED WITH YOUR SUPPLY VALVE. INSERT THE INLET LINE INTO THE SUPPLY VALVE UNTIL IT BOTTOMS OUT. THREAD THE NUT DOWN ONTO THE SUPPLY VALVE UNTIL FINGER TIGHT. DRAW A LINE ON THE NUT USING A MARKER. TIGHTEN EXACTLY ONE ADDITIONAL FULL (360°) TURN WITH A WRENCH, USING THE LINE TO COUNT TURNS. CONNECT THE HOT AND COLD WATER SUPPLY LINES TO THE TMV WITH SIDES MARKED "H" FOR HOT AND "C" FOR COLD USING THE SAME PROCESS.

**NOTE:** DO NOT SUBSTITUTE BRAIDED FLEX HOSES FOR THE PEX TUBING.

TEMPERED WATER TO FAUCET

TEMPERED WATER TO EYE/FACE WASH

HOT WATER SUPPLY COMPRESSION FITTING

HOT WATER STRAINER

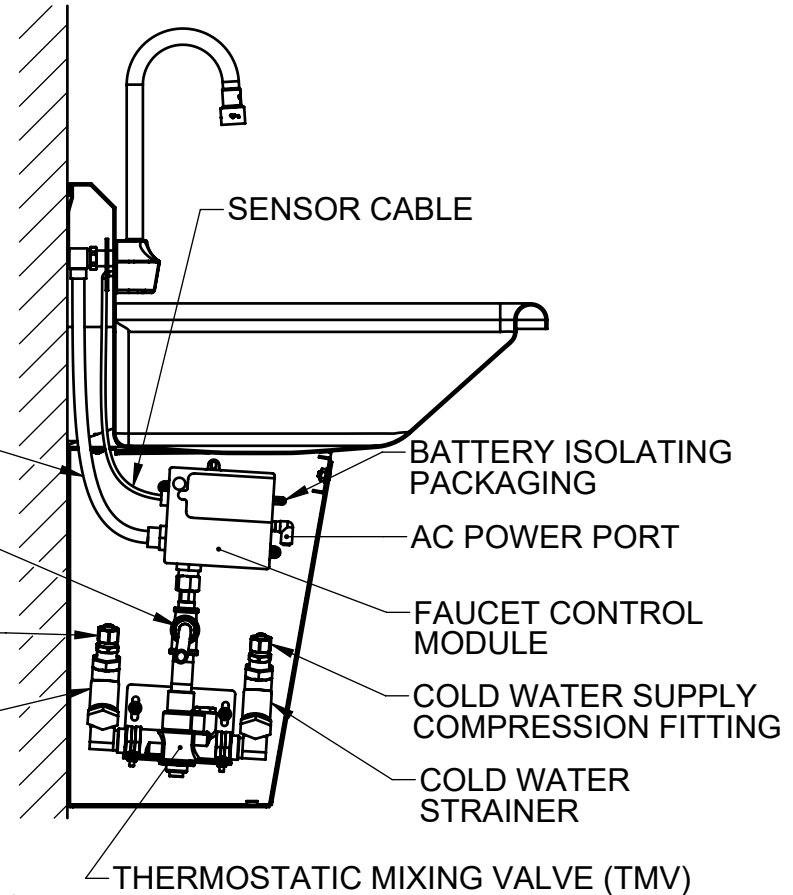

**STEP 6**  
 CONNECT THE 3/8" PEX TUBING FROM THE EYE/FACE WASH TO THE COMPRESSION FITTING LOCATED JUST ABOVE THE TMV, FOLLOW THE SAME PROCESS DESCRIBED IN STEP 5. CONNECT THE FAUCET BRAIDED FLEX HOSE AND SENSOR CABLE TO THE BACK SIDE OF THE FAUCET CONTROL MODULE. REMOVE THE PACKAGING THAT ISOLATES THE FAUCET BATTERIES BY PULLING ON THE PLASTIC TAB NEAR THE BATTERY COMPARTMENT OF THE FAUCET CONTROL MODULE. IF A 120V OUTLET IS INSTALLED UNDER THE SINK, PLUG IN THE FAUCET WALL ADAPTER AND CONNECT IT TO THE FRONT OF THE CONTROL MODULE.

**STEP 7**  
 CONNECT THE DRAIN TAILPIECE AND P-TRAP TO THE SINK AND WALL DRAIN USING THE SUPPLIED SLIP JOINT CONNECTIONS.



1455 KLEPPE LANE  
 SPARKS, NEVADA 89431  
 (775) 359-4712 FAX (775) 359-7424  
 E-MAIL: HAWS@HAWSCO.COM  
 WEBSITE: WWW.HAWSCO.COM

ECN: 5806	REV. ECN: 5902	BY: FV	MODEL(S): 7660 & 7661	PART NUMBER: 0510002058.D
DRAWN: DHP	DATE: 03/25/23	CHKD: JU	EYE/FACE WASH AND HANDWASH STATION	REVISION: 3
APPROVED: DHP	DATE: 05/26/23	SCALE: 1:8	DRAWING TYPE: INSTALLATION	SHEET 6 OF 7

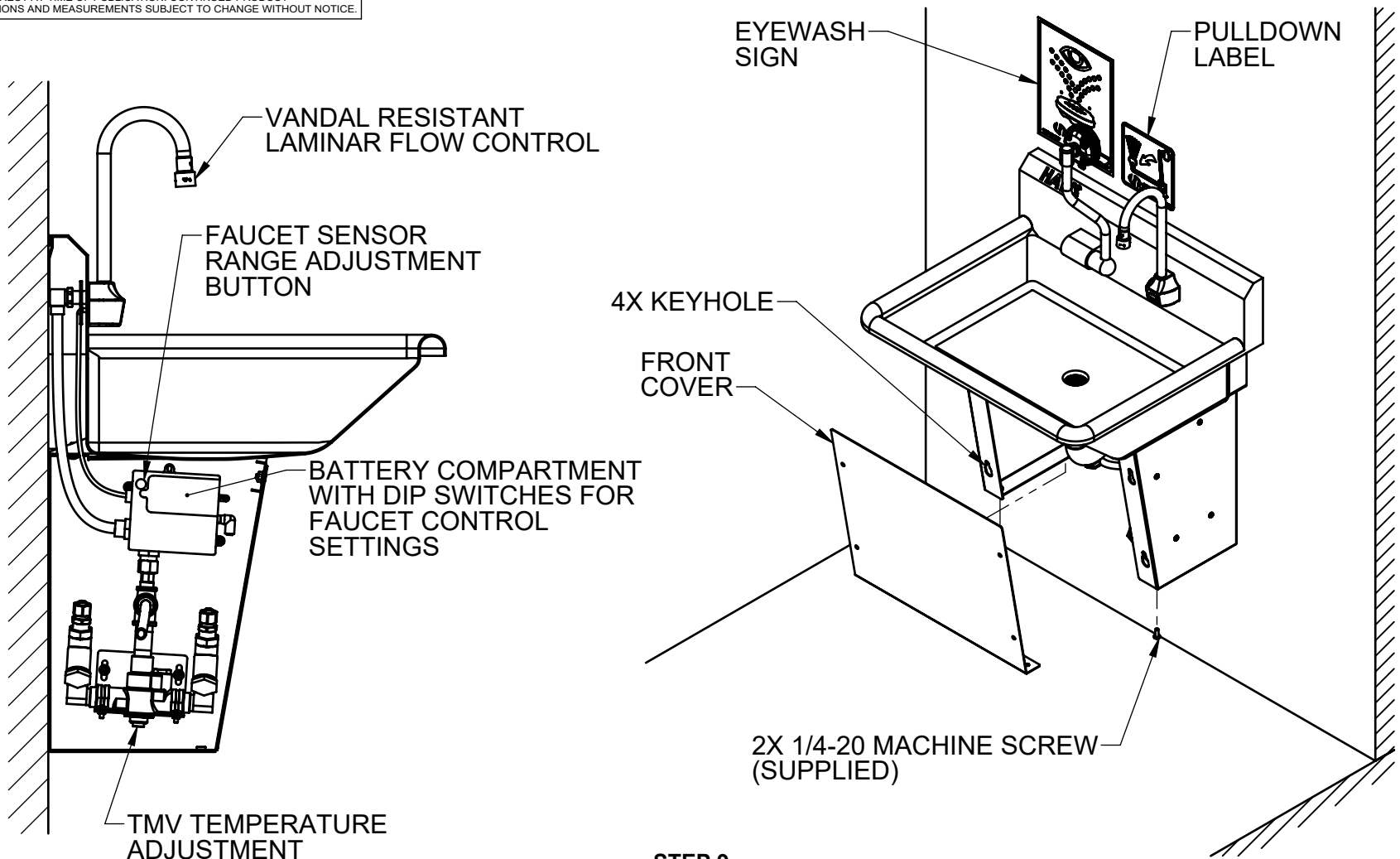

**STEP 8**

OPEN BOTH STOP VALVES, TEST THE EYE/FACE WASH AND FAUCET, AND CHECK FOR LEAKS. ADJUST THE TMV TEMPERATURE SETTING IF REQUIRED (REFER TO HAWS 9201EW OWNERS MANUAL FOR INSTRUCTIONS). REFER TO INCLUDED FAUCET OWNERS MANUAL FOR INSTRUCTIONS ON ADJUSTING FAUCET SENSOR RANGE, SHUT-OFF DELAY, AND TIME-OUT SETTINGS. FAUCET IS SHIPPED WITH A 1.2 GPM LAMINAR FLOW CONTROL (INSTALLED) AND 0.5 GPM LAMINAR FLOW CONTROL; 2.2 GPM LAMINAR FLOW CONTROL MAY BE AVAILABLE UPON REQUEST DEPENDING ON YOUR STATE AND LOCAL CODES.

**STEP 9**

INSTALL THE STAINLESS STEEL FRONT COVER BY PLACING THE 4 SHOULDER RIVETS ATTACHED TO THE FRONT COVER IN THEIR RESPECTIVE KEY HOLES ON THE SUPPORT BRACKETS. LIFT THE FRONT COVER UNTIL THE FRONT COVER IS FLUSH WITH THE SUPPORT BRACKETS, AND INSTALL TWO 1/4-20 MACHINE SCREWS FROM BELOW TO HOLD THE FRONT COVER IN PLACE. DO NOT USE POWERED TOOLS ON THESE SCREWS OR THEY MAY SEIZE. POSITION THE SUPPLIED EYEWASH SIGN AND PULLDOWN LABEL SUCH THAT IT IS VISIBLE WITHIN THE AREA SERVED BY THE EYEWASH.

		1455 KLEPPE LANE SPARKS, NEVADA 89431 (775) 359-4712 FAX (775) 359-7424 E-MAIL: HAWS@HAWS.CO.COM WEBSITE: WWW.HAWS.CO.COM			
		ECN: 5806 DRAWN: DHP APPROVED: DHP	REV. ECN: 5902 DATE: 03/25/22 DATE: 05/26/23	BY: FV CHKD: JU	MODEL(S) 7660 & 7661 EYE/FACE WASH AND HANDWASH STATION
SCALE: 1:8		DRAWING TYPE: INSTALLATION		SIZE: A	SHEET 7 OF 7