



Haws®

model H1011.8HPSHO

Chilled Vandal-Resistant ADA Motion-Activated/Push Button High-Polished Fountain

FEATURES & BENEFITS

CONSTRUCTION

Rugged ADA accessible 18 gauge Type 304 high polished Stainless Steel swirl design bowl, 14 gauge Type 304 high polished Stainless Steel bracket, and a vandal-resistant bottom plate provides a long lasting unit with added peace of mind.

TAMPER RESISTANT

30-second obstruction time-out to reduce tampering of sensor.

MOUNTING

Heavy-duty 16-gauge galvanized steel mounting frame with welded-in heavy-duty 10 gauge mounting plate with pre-punched mounting holes. Further convenience is given to the chiller with the integral fold-out shelf.

BUBBLER HEADS

Polished chrome-plated brass bubbler head with integral laminar flow prevents splashing while providing a superior flow pattern. The integral 1 1/16" dia. basin shank and stainless anti-rotation roll pin for vandal resistance strength. Shielded, angled stream opening provides a steady source of drinking water at .45 gpm.

FOUNTAIN VALVES

Fountain incorporates a touchless sensor operated stainless steel solenoid valve controlled by a transformer on one side and a push-button activated valve which offers the only all stainless steel valve body that is machined out of solid bar stock and is fully serviceable through the front of the push button assembly offering access to the water control cartridge and integral water supply strainer on the other.

VANDAL-RESISTANT

The bubbler heads, push buttons, round bowls, drain strainers and bottom plates are locked in place, discouraging unwanted vandal tampering.



SPECIFICATIONS

Model H1011.8HPSHO electric vandal-resistant ADA wall-mounted combination motion activated/push button drinking fountain shall include dual 18 gauge Type 304 polished stainless steel basins with integral swirl design, 14 gauge Type 304 polished stainless steel wall brackets, 100% lead-free waterways, touchless sensor operated solenoid valve with 30-second obstruction time-out on one side, and vandal-resistant push-button operated stainless steel valve with front-accessible cartridge and flow adjustment on the other, polished chrome-plated brass vandal-resistant bubbler heads with integral laminar anti-squirt flow, chrome-plated brass vandal-resistant waste strainers, vandal-resistant bottom plates, high-polished stainless steel back panel and louvered intrusion-proof grill, high and low fountain mounting levels, and 1-1/4" O.D. (3.2 cm) waste pipes. The R-134a refrigeration system is hermetically sealed and delivers a minimum of 8 gph (30.3 L) of water at 50° F (10° C) cooled from 80° F (26.7° C) inlet water at 90° F (32.2° C) ambient. 115 Volts, 60 Hz, rated watts: 370, full load amps.

REQUIRES MODEL HCR8 AND MTGFR.LG PRICED SEPARATELY.

FOR INDOOR USE ONLY APPLICATIONS

Specifically, this type fountain may be placed in settings such as: schools, office buildings, shopping malls, and other indoor environments where there is a demand for a chilled water source and/or wheelchair access. Electric water coolers are not recommended or designed for outdoor applications or enclosed pool areas (chlorine). These conditions may void warranty. Model meets all current Federal Regulations for the disabled including those in the Americans with Disabilities Act. Haws manufactures drinking fountains, faucets and electric water coolers to be lead-free by all known definitions including NSF/ANSI/CAN 61- Section 9, NSF/ANSI/CAN 372, California Proposition 65, and the Federal Safe Drinking Water Act. Product is compliant to California Health and Safety Code 116875 (AB 1953-2006), and NSF/ANSI/CAN 61: Q ≤ 1. Haws electric water coolers comply with ARI Standard 1010 and ANSI A117.1, and are listed by Underwriter Laboratories to U.S. and Canadian standards.

OPTIONS

- Cane Detection, Floor Mounted: Model SK6, floor mounted cane detection for the Haws Hi-Lo drinking fountains.
- Custom Logo Panel: Model 6475, Hydration By Haws™ logo panel with customization options.
- Bottle Filler: Model 1920HPSHO, bottle filler can be a stand-alone station, or mounted above Haws 1001HPS and 1011HPS series drinking fountain models.
- Back Panel: Model BP32HPS, satin finish stainless steel 32" back panel for model 1920HPS bottle filler.

For more information, visit www.hawsc.com or call (888) 640-4297.



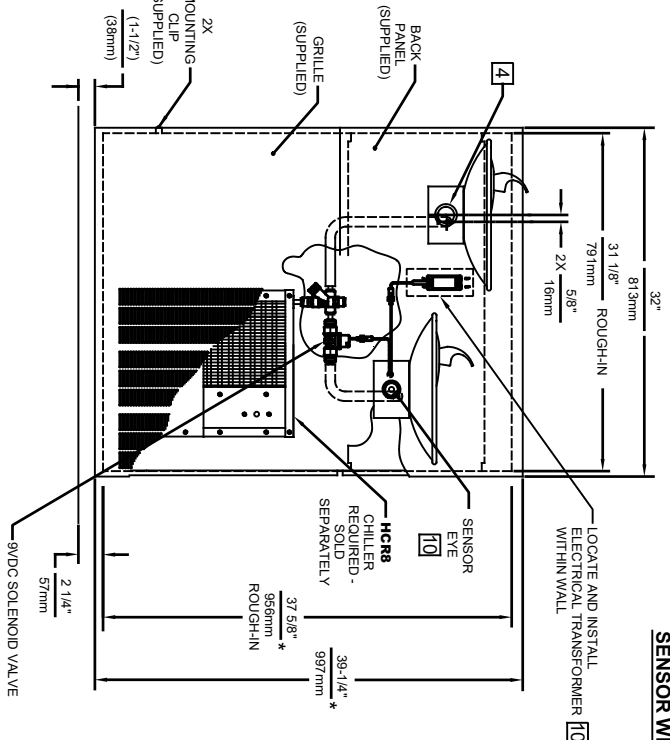
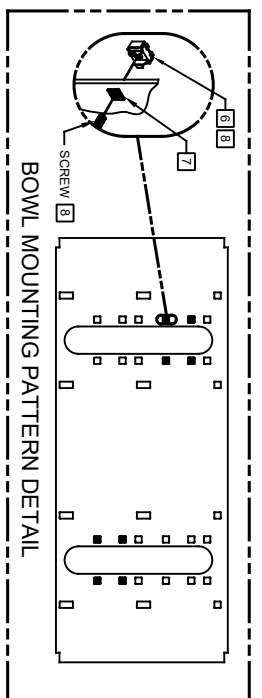
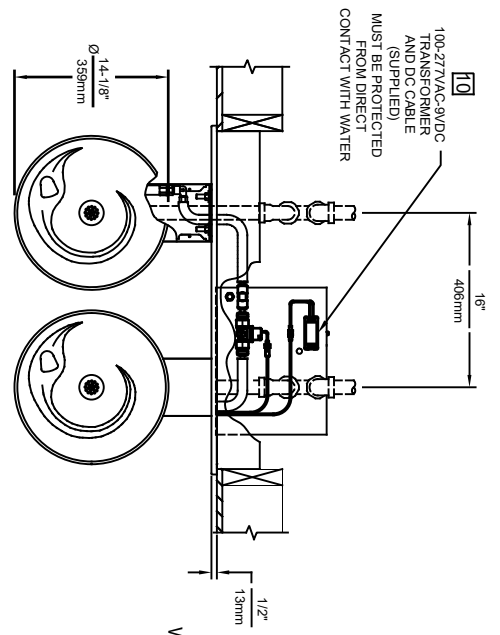

MODEL H1011.8HO SHOWN
 MODEL H1011.8HO2 ON SHEET 2
 (ROUGH-IN DIMENSIONS APPLY TO BOTH MODELS WITH EXCEPTION NOTED ON SHEET 2)

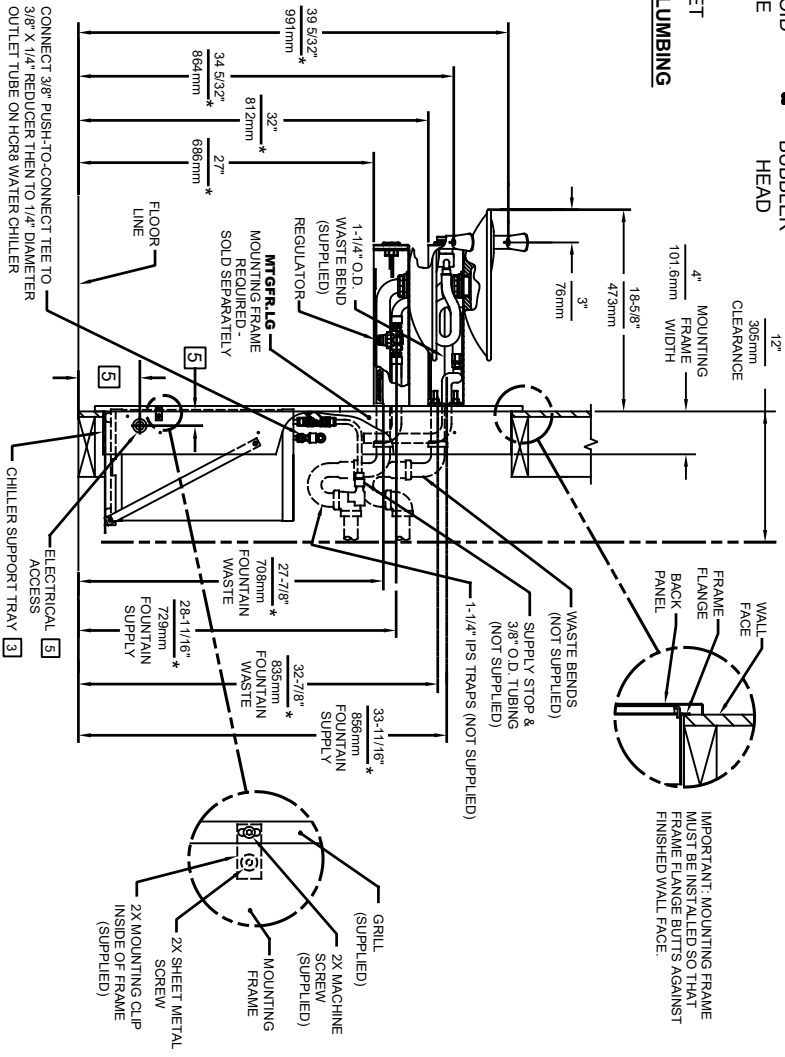

- NOTES:
- HOLD ROUGH-IN DIMENSIONS ±1/8" (3.2mm).
 - WHEN INSTALLING THIS UNIT, LOCAL STATE OR FEDERAL CODES SHOULD BE REFERRED TO FOR INSTALLATION DIMENSIONS (LOCATIONS, WASTE AND MOUNTING DIMENSIONS SHOWN). DIMENSIONS MARKED (*) MUST BE ADJUSTED ACCORDINGLY.
 - ALIGN HOLES IN CHILLER SUPPORT TRAY WITH HOLES IN FRAME AND FASTEN WITH #10 SHEETMETAL SCREWS.
 - REFER TO 5874 SERIES OPERATION AND MAINTENANCE MANUAL FOR PUSH BUTTON AND VALVE INSTALLATION/MAINTENANCE INSTRUCTIONS.
 - REFER TO MTFRGLD INSTALLATION DRAWING FOR ROUGH-IN DIMENSIONS.
 - INSERT 5/16"-18 PANEL INSERTS FROM OPPOSITE SIDE AT LOCATIONS SHOWN BY PARKENED HOLES. HOLE COMBINATIONS SHOWN ARE FOR USE WITH LOW FOUNTAIN ON THE RIGHT AND HI FOUNTAIN ON THE LEFT. USE OPPOSITE HOLES FOR HI ON RIGHT AND LOW ON LEFT.
 - HOLE COMBINATION SHOWN BELOW IS FOR USE WITH LOW FOUNTAIN ON THE RIGHT AND HIGH FOUNTAIN ON THE LEFT. USE OPPOSITE HOLES FOR HIGH ON RIGHT AND LOW ON LEFT.
 - TO CHANGE FOUNTAIN MFG. SCREW LOCATIONS: FIRST REMOVE SCREWS AND THEN SQUEEZE CLIPS ON NUT REMAINDER TO POP OUT. SNAP INTO NEW POSITIONS AND REASSEMBLE SCREWS.
 - IMPORTANT: A L.H. LOW (OPTIONAL) CONFIGURATION WILL REQUIRE A DIFFERENT BACK PANEL AND THE WASTE AND SUPPLY DIMENSIONS SHOWN (*) MUST BE REVERSED.
 - REFER TO 4RKH0.4 & 2RKH0.4 OPERATION AND MAINTENANCE INSTRUCTIONS FOR TRANSFORMER AND SENSOR SETUP.

1456 KLEPPE LANE
 SPARKS, NEVADA 89431
 (775) 359-4712 FAX (775) 359-7424
 E-MAIL: HAWS@HAWS.CO.COM
 WEBSITE: WWW.HAWS.CO.COM

ECN NO. REVISED PER/REV.	MODEL(S)
ECN 5988 DP	H1011.8HO/H1011.8HO2
DRAWN: RTM	DATE: 07/97
APPROVED: BLM	DATE: 09/3/21
SCALE: NA	DRAWING TYPE: INSTALLATION
SHEET 1 OF 2	

PART NUMBER 0002080250.D
 REVISION 28

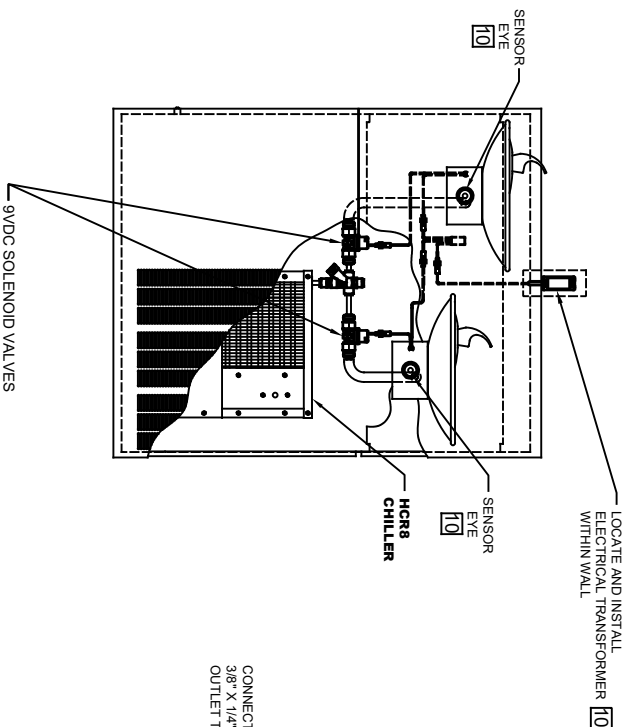
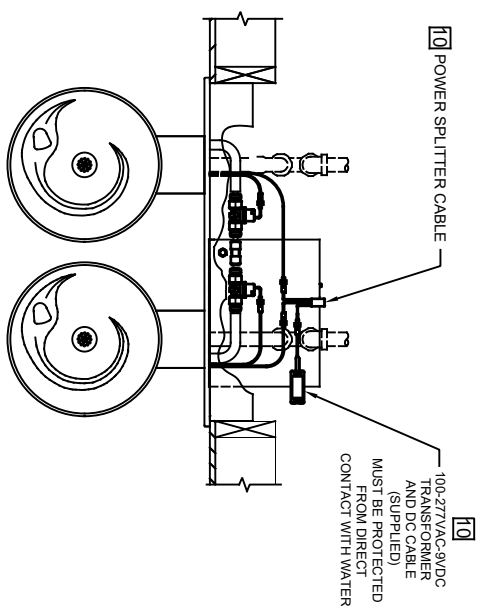

CONNECT 3/8" PUSH-TO-CONNECT TEE TO 3/8" X 1/4" REDUCER THEN TO 1/4" DIAMETER OUTLET TUBE ON HCR8 WATER CHILLER

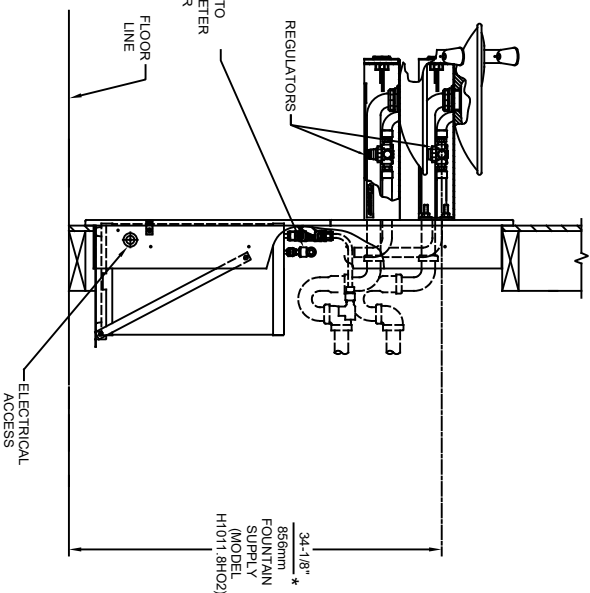
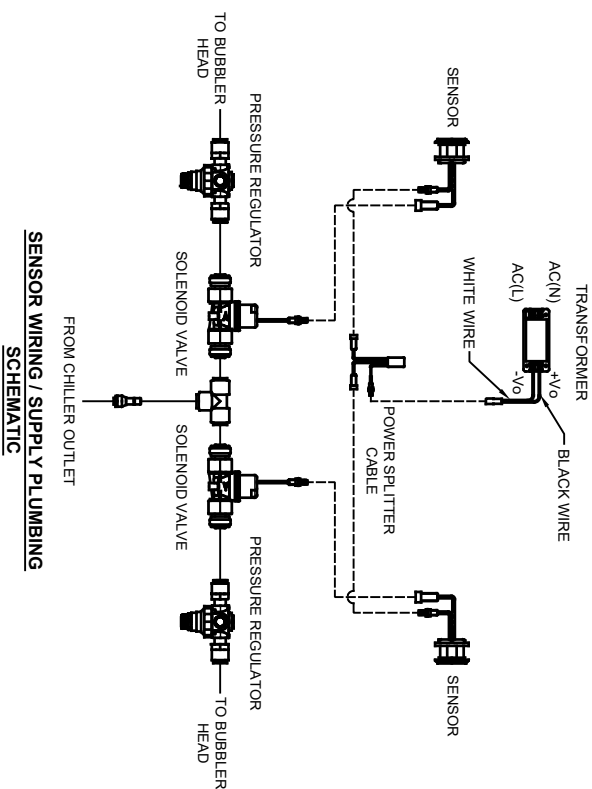

MODEL H1011.8HO2 SHOWN
MODEL H1011.8HO ON SHEET 1
(SEE SHEET 1 FOR APPLICABLE ROUGH-IN DIMENSIONS)

		MODEL(S)	
1458 KLEPPE LANE SPARKS, NEVADA, 89431 (775) 359-4712 FAX (775) 359-7424 E-MAIL: HAWS@HAWS.CO.COM WEBSITE: WWW.HAWS.CO.COM		H1011.8HO/H1011.8HO2	
ECN NO. REVISED PER BY:	DATE:	DP:	CHKD:
ECN: 5688	07/22/20		
APPROVED:	DATE:	SCALE:	DRAWING TYPE:
BJM	09/30/21	NA	INSTALLATION
PART NUMBER		REVISION	
0002080250.D		28	