



# model H1001.8HPS

ADA Vandal-Resistant Chilled Wall-Mount Fountain

## FEATURES & BENEFITS

### CONSTRUCTION

18 gauge Type 304 stainless Steel swirl design bowl, 14 gauge Type 304 Stainless Steel bracket, and a vandal-resistant bottom plate provides a long lasting unit with added peace of mind.

### QUALITY CONTROL

Pre-built fountain is pressure tested to ensure no leaks and proper functionality.

### MOUNTING

Heavy-duty 16-gauge galvanized steel mounting frame with welded-in heavy-duty 10 gauge mounting plate with pre-punched mounting holes. Further convenience is given to the chiller with the integral fold-out shelf.

### BUBBLER HEAD

Polished chrome-plated brass bubbler head with integral laminar flow prevents splashing while providing a superior flow pattern. The integral basin shank and inserted roll pin add vandal resistance strength. Shielded, angled stream opening provides a steady, sanitary source of drinking water at .45 gpm.

### PUSH BUTTON VALVE

The push-button activated valve assembly allows for front access stream adjustment as well as cartridge and strainer access. The valve works at an operating pressure range of 30 to 90 psi (2.1 to 6.2 bar).

### VANDAL-RESISTANT

The bubbler head, push button, round bowl, drain strainer and bottom plate are locked in place, discouraging unwanted vandal tampering.

## OPTIONS

Water Filter: Model 6426, 10" x 2" (25.4 x 5.1 cm), in-line lead removal element that reduces lead from incoming water supply.

Bottle Filling Station: Model 1900, bottle filler can be a stand-alone station, or mounted above most Haws drinking fountains along with most competitors' fountains and water coolers.

High Polished Bottle Filler: Model 1920HPS, polished stainless steel bottle filler can be a stand-alone station, or mounted above Haws 1001HPS and 1011HPS series drinking fountain models.

Back Panel: Model BP15HPS, polished stainless steel 15" back panel for Model 1920HPS.

For more information, visit [www.hawsc.com](http://www.hawsc.com) or call (888) 640-4297.



## SPECIFICATIONS

Model H1001.8HPS electric vandal-resistant wall-mounted barrier-free water cooler shall include an 18 gauge Type 304 polished stainless steel finish basin with integral swirl design, 14 gauge Type 304 high-polished stainless steel wall bracket, 100% lead-free waterways, vandal-resistant push-button operated stainless steel valve with front-accessible cartridge and flow adjustment, polished chrome-plated brass vandal-resistant bubbler head with integral laminar anti-squirt flow, chrome-plated brass vandal-resistant waste strainer, vandal-resistant bottom plate, polished stainless steel finish back panel and louvered intrusion-proof grill, and 1-1/4" (3.2 cm) O.D. waste pipe. The R-134a refrigeration system is hermetically sealed and delivers a minimum of 8 gph (30.3 L) of water at 50° F (10° C) cooled from 80° F (26.7° C) inlet water at 90° F (32.2° C) ambient. 115 Volts, 60Hz, rated watts: 370, full load amps: 5.

**REQUIRES MODEL HCR8 AND MTGFR.SM PRICED SEPARATELY.**

## APPLICATIONS

This series is precisely mounted, making it a nice addition to any surrounding. Specifically, this type fountain may be placed in settings such as: schools, office buildings, shopping malls, and other indoor environments. Electric water coolers are not recommended or designed for outdoor applications or enclosed pool areas (chlorine). These conditions may void warranty. Model meets all current Federal Regulations for the disabled including those in the Americans with Disabilities Act. Haws manufactures drinking fountains, faucets and electric water coolers to be lead-free by all known definitions including NSF/ANSI/CAN 61-Section 9, NSF/ANSI/CAN 372, California Proposition 65, and the Federal Safe Drinking Water Act. Product is compliant to California Health and Safety Code 116875 (AB 1953-2006), and NSF/ANSI/CAN 61: Q ≤ 1. Haws electric water coolers comply with ARI Standard 1010 and ANSI A117.1, and are listed by Underwriter Laboratories to U.S. and Canadian standards.



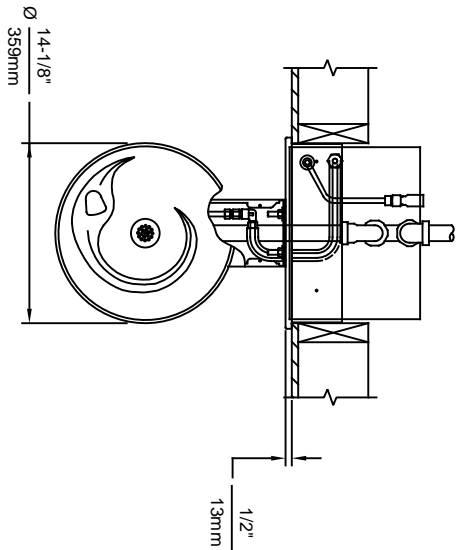

REMOVE VALVE FROM PUSH BUTTON TO INSTALL WASTE ELBOW ONTO BOWL. AFTER WASTE ELBOW IS INSTALLED, REINSTALL VALVE & ADJUST FLOW.

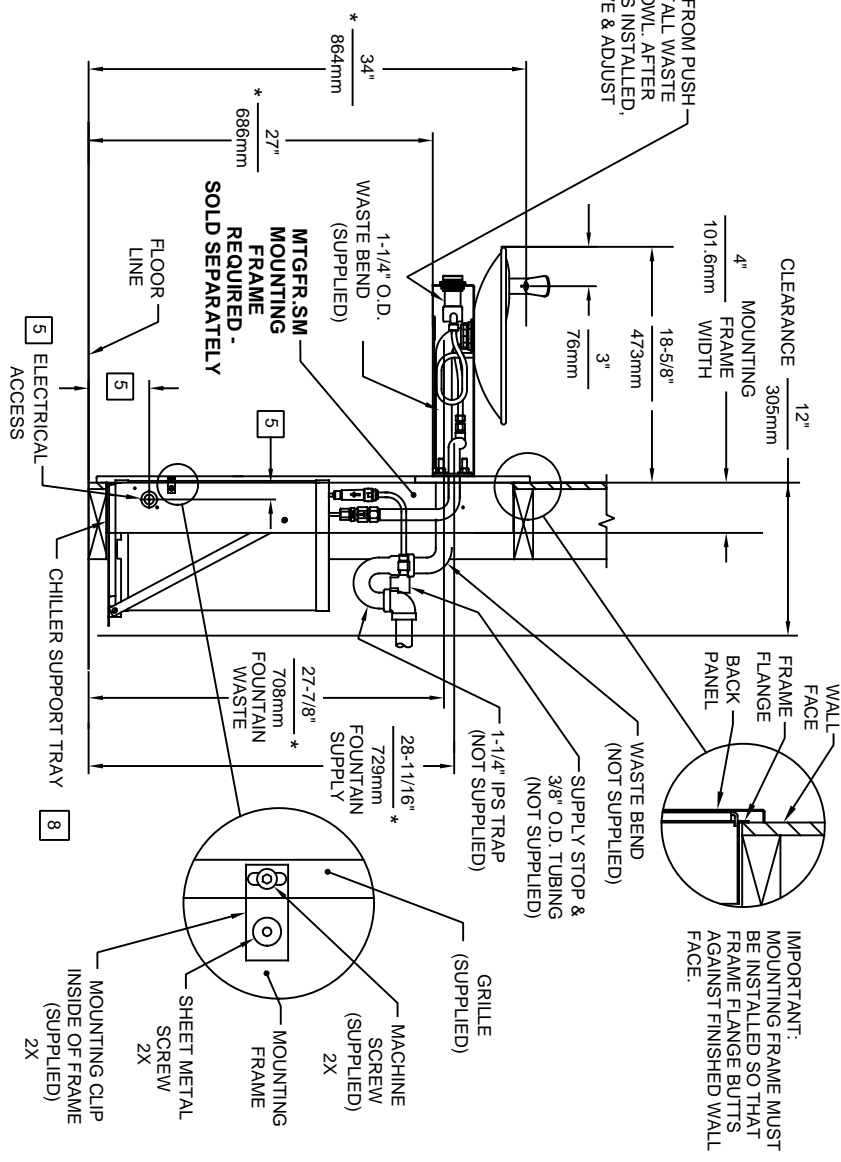
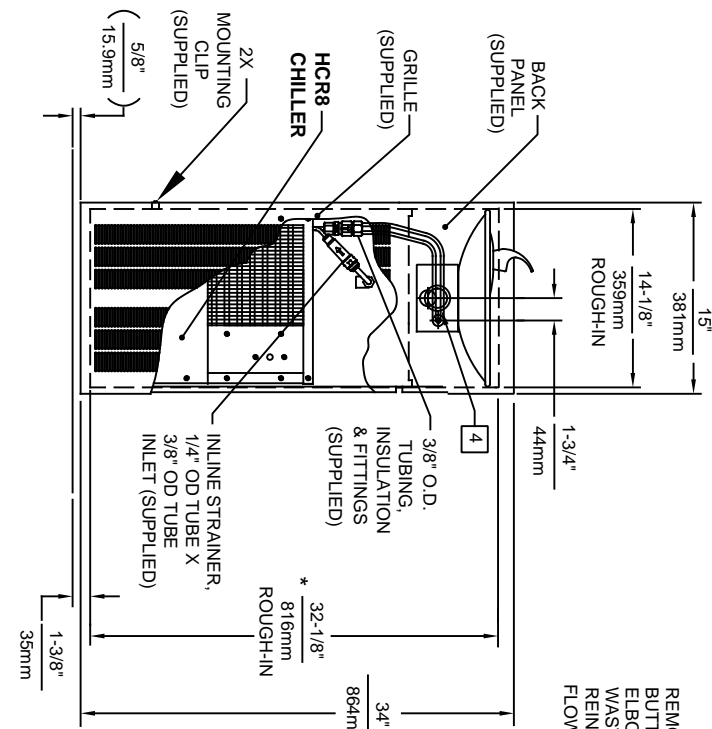

- NOTES:**
- HOLD ROUGH-IN DIMENSIONS  $\pm 1/8"$  (3.2mm).
  - WHEN INSTALLING THIS UNIT, LOCAL, STATE, OR FEDERAL CODES SHOULD BE ADHERED TO. FOR DIMENSIONS (LOCATIONS), WASTE AND SUPPLY REQUIREMENTS, OTHER THAN SHOWN, DIMENSIONS MARKED (\*) MUST BE ADJUSTED ACCORDINGLY.
  - INSTALLER MUST PROVIDE TRAP FOR PROPER INSTALLATION.
  - REFER TO 587ASS OPERATION AND MAINTENANCE MANUAL FOR PUSH BUTTON AND VALVE INSTALLATION/MAINTENANCE INSTRUCTIONS.
  - REFER TO MTGFR-SM INSTALLATION DRAWING FOR ROUGH-IN DIMENSIONS.
  - INSERT 5/16"-18 PANEL INSERTS FROM OPPOSITE SIDE AT LOCATIONS SHOWN BY DARKENED HOLES.
  - FOUNTAIN REMOVAL: FIRST REMOVE SCREWS AND THEN SQUEEZE CLIPS ON NUT RETAINER TO POP OUT. INSTALL IS REVERSE OF REMOVAL.
  - ALIGN HOLES IN CHILLER SUPPORT TRAY WITH HOLES IN FRAME AND FASTEN WITH #10 SHEET METAL SCREWS.

IMPORTANT: MOUNTING FRAME MUST BE INSTALLED SO THAT BACK FLANGE BUTTS AGAINST FINISHED WALL FACE.

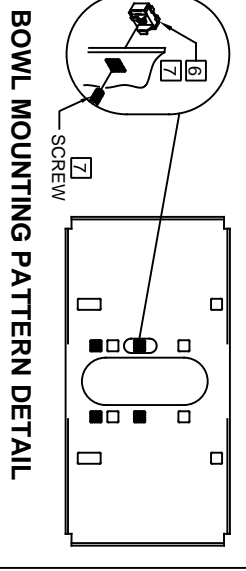

**BOWL MOUNTING PATTERN DETAIL**

1456 KLEPPPE LANE  
SPARKS, NEVADA 89431  
(775) 359-4712 FAX (775) 359-7424  
E-MAIL: HAWKS@HAWSCO.COM  
WEBSITE: WWW.HAWSCO.COM

ECN NO. REVISED PER BY: MODEL(S)  
ECN: 5527 EV: H1001.8/H1001.8HPS

DRAWN: DATE: CHK'D: DATE: RTM: DP: APPROVED: EV: DATE: SCALE: 1:15 DRAWING TYPE: INSTALLATION SIZE: A SHEET 1 OF 1

PART NUMBER: 0002080246.D  
REVISION: 20