

FEATURES & BENEFITS

CONSTRUCTION

Barrier-free designed fountain for child or adult ADA access. Made of air-entrained concrete with exposed aggregate finish and galvanized wire. Air entrainment ensures strength and freeze-thaw durability. Unit has a stainless steel basin, and hood extension to protect the bubbler head with a partial enclosure. Vandal-resistant bottom plate, and chrome-plated 1-1/2" (3.81 cm) IPS trap.

DRAIN CLEAN-OUT

Top-down access to the drain allows the fountain portion to be cleaned without taking the unit apart, good for outdoor settings with drain-clogging sediment such as leaves, garbage, and other debris.

BARRIER FREE

Designed for Adult or Child ADA access, the spacious fountain design allows for the trap to be internally mounted which allows for easy access.

MOUNTING

3/16" (.47 cm) steel mounting plate (sold separately) with supplied mounting hardware for a solid unit base allows for easy installation to a framed wall.

BUBBLER HEAD

Polished chrome-plated brass bubbler head with integral basin shank for added strength. Shielded, angled stream opening provides a steady, sanitary source of drinking water at .45 gpm.

DRINKING FOUNTAIN VALVE

The push-button activated valve offers the only all stainless steel valve body that is machined out of solid bar stock, is fully serviceable through the front of the push button assembly offering access to the water control cartridge and integral water supply strainer, and with front access to the water stream height adjustment for easy maintenance without having to remove the valve. Operating pressure range of 30 to 90 psi (2.1 to 6.2 bar).

VANDAL RESISTANT

The bubbler head, push button, drain strainer and bottom plate are locked in place, discouraging unwanted vandal tampering.



SPECIFICATIONS

Model 1047 vandal-resistant wall mount adult or child ADA drinking fountain shall include a stainless steel basin contained in an air-entrained concrete wall bracket with exposed aggregate finish, 100% lead-free waterways, vandal-resistant push-button operated valve with front-accessible cartridge and flow adjustment, polished chrome-plated brass vandal-resistant bubbler head, polished chrome-plated brass vandal-resistant waste strainer with top-down access, vandal-resistant bottom plate, and chrome-plated 1-1/2" NPT trap.

REQUIRES MODEL 6700 PRICED SEPARATELY

APPLICATIONS

Perfect for either public or private settings, our concrete series is a great fit in "open-air" environments. Suitable in areas where weather conditions may be cause for concern, this series stands strong from the forest to the beach. Reinforced concrete design not only protects from corrosion, its Portland gray color makes it recognizable enough to locate without compromising the outdoor atmosphere. Specifically, this type of wall mounted drinking fountain may be placed in settings such as: parks, schools, and other recreational outdoor environments where the temperature remains above freezing. Model meets all current Federal Regulations for the disabled including those in the Americans with Disabilities Act. Haws manufactures drinking fountains, faucets and electric water coolers to be lead-free by all known definitions including NSF/ANSI/CAN 61-Section 9, NSF/ANSI/CAN 372, California Proposition 65, and the Federal Safe Drinking Water Act. Product is compliant to California Health and Safety Code 116875 (AB 1953-2006), and NSF/ANSI/CAN 61: Q ≤ 1.

OPTIONS

- Support Frame: Model 6800 universal in-wall mounting support for use with most fountains.
- Remote Drinking Fountain Water chiller: Model HCR8, 8 gph (30.3 L) remote water chiller provides instantaneous cooling to meet a continuous demand for chilled water.

For more information, visit www.hawsco.com or call (888) 640-4297.



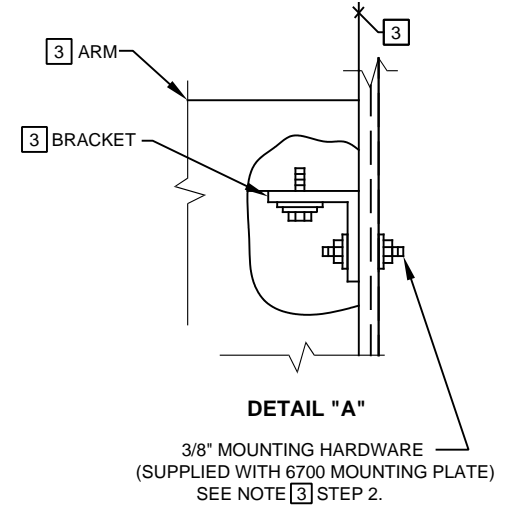
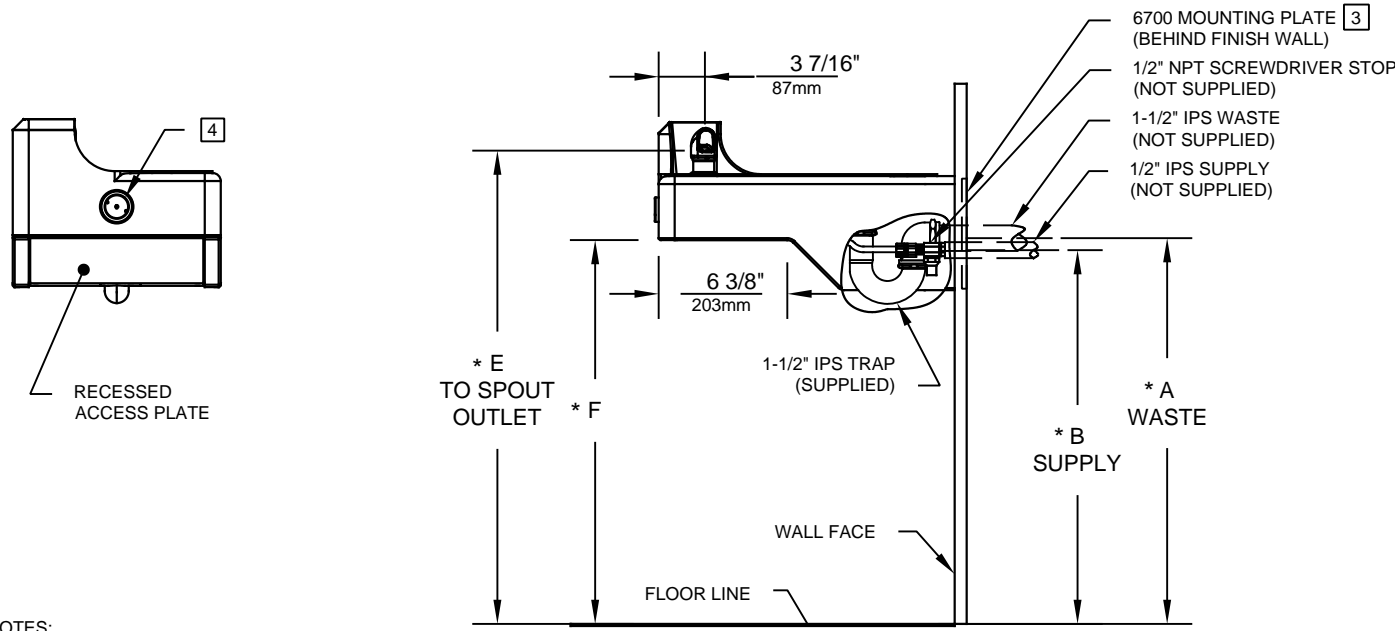
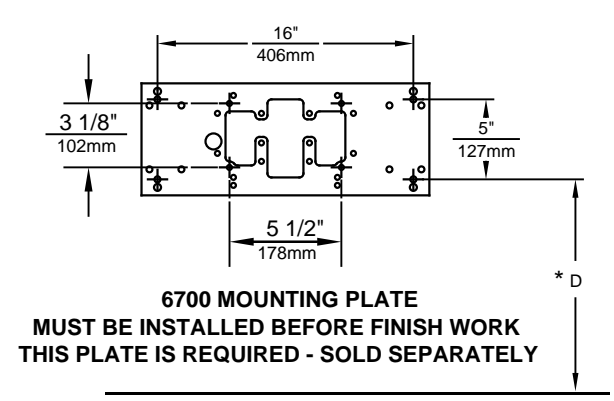
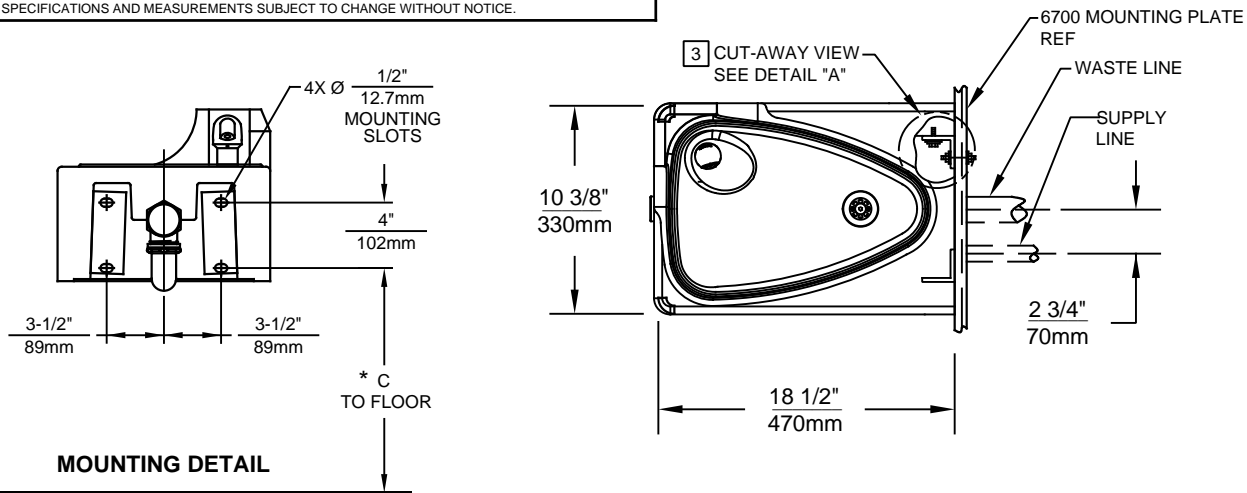

NOTES:

1. HOLD ROUGH-IN DIMENSIONS $\pm 1/4"$ (6.4mm).
2. WHEN INSTALLING THIS UNIT, LOCAL, STATE OR FEDERAL CODES SHOULD BE ADHERED TO. FOR INSTALLATION HEIGHTS OTHER THAN SHOWN, DIMENSIONS MARKED (*) MUST BE ADJUSTED ACCORDINGLY.
3. **PROCEDURE FOR ASSEMBLING ARM TO WALL:**
IMPORTANT: L-BRACKETS ARE PRE-ASSEMBLED AND **MUST NOT** BE LOOSENER FOR ANY REASON.
STEP 1: ATTACH ENTIRE ARM ASSEMBLY TO WALL USING 6700 MOUNTING PLATE (SUPPLIED) USING THE 3/8"-16 X 4" THREADED RODS, WASHERS AND NUTS (SUPPLIED WITH 6700 MTG PLT) AND TIGHTEN SECURELY IN PLACE.
STEP 2: (OPTIONAL) APPLY CAULKING AS NEEDED TO FILL ANY GAP PRESENT BETWEEN ARM AND PEDESTAL.
4. REFER TO 5874 SERIES OPERATION AND MAINTENANCE MANUAL FOR PUSH BUTTON AND VALVE INSTALLATION/MAINTENANCE INSTRUCTIONS.

DIM	ADULT ADA	CHILD ADA
A	27-1/2" / 699mm	24-1/2" / 622mm
B	26-3/8" / 670mm	23-3/8" / 594mm
C	25-1/8" / 638mm	22-1/8" / 562mm
D	24-3/8" / 619mm	21-3/8" / 543mm
E	32-3/4" / 832mm	29-3/4" / 756mm
F	27" / 686mm	24" / 610mm

1455 KLEPPE LANE
 SPARKS, NEVADA 89431
 (775) 359-4712 FAX (775) 359-7424
 E-MAIL: HAWS@HAWSCO.COM
 WEBSITE: WWW.HAWSCO.COM

ECN NO. 4144	REVISED PER ECN: 5527	BY: FV	MODEL(S)	PART NUMBER
DRAWN: SLS	DATE: 07/22/08	CHKD: DP	1047	0002076418.D
APPROVED: FV	DATE: 04/02/20	SCALE: N/A	DRAWING TYPE: INSTALLATION	REVISION 21
			SIZE: A	SHEET 1 OF 1