



model 1119FR

ADA Outdoor Freeze-Resistant Vandal-Resistant Drinking Fountain

FEATURES & BENEFITS

CONSTRUCTION

Unit is made of 18 gauge Type 304 stainless steel with a satin finish that resists stains and corrosion, and has soft, rounded corners. Unit features stainless steel satin finish back panel, vandal-resistant bottom plate, and 1-1/4" integral trap.

FREEZE-RESISTANT VALVE

Fully engineered system with the pneumatic-operated, freeze-resistant valve mounted in a cabinet that is installed on the inside wall where room temperature does not drop below 50° F (10° C). When valve goes to off position, water left in supply line between valve and bubbler drains back into waste inside cabinet, protecting the unit from freezing, and allowing fountain to function year-round.

BACK PANEL

Stainless steel back panel helps to protect the wall from inadvertent splashing, and its decorative satin finish increases location visibility.

BARRIER-FREE

Barrier-free capabilities combined with its ease of use allows for a number of installation location possibilities.

BUBBLER HEAD

Polished chrome-plated brass bubbler head with integral basin shank for added strength. Shielded, angled stream opening provides a steady, sanitary source of drinking water at .45 gpm.

VANDAL-RESISTANT

The bubbler heads, push buttons, drain strainers and bottom plates are locked in place, discouraging unwanted vandal tampering.



SPECIFICATIONS

Model 1119FR vandal-resistant wall mounted barrier-free freeze-resistant drinking fountain shall include dual 18 gauge Type 304 Stainless Steel satin finish basins, polished chrome-plated brass vandal-resistant bubbler heads, polished chrome-plated brass push-buttons which operate pneumatic valves, housed in insulated cabinets, installed on the inside wall where room temperatures do not drop below 50° F (10° C), self-draining water lines protect the unit from freezing, polished chrome-plated brass vandal-resistant waste strainers, stainless steel satin finish back panel, high and low fountain mounting levels, and 1-1/4" O.D. waste pipes.

REQUIRES MODEL 6521FR (QTY2) PRICED SEPARATELY.

OPTIONS

- Cane Detection, Floor Mounted: Model SK6, floor mounted cane detection for the Haws Hi-Lo drinking fountains.
- Freeze-Resistant Bottle Filler: Model 1920FR, freeze-resistant bottle filler can be a stand-alone wall mounted station, or mounted over the 1109FR & 1119FR series fountains.
- Mounting Plate: Model 6700.4 "Hi-Lo" universal mounting plate for most dual bubbler fountains. Priced Separately
- Support Frame: Model 6800 universal in-wall mounting support for use with most fountains.

For more information, visit www.hawsc.com or call (888) 640-4297.

APPLICATIONS

Perfect for either public or private outdoor settings, Model 1119FR is a great fit in areas where aesthetics are important to the overall appeal of the architecture. This series is precisely mounted, making it a nice addition to any surrounding. Beautiful satin finish helps to maintain the fountains overall appeal so it always remains looking as new as it did when it was installed. Specifically, this type of wall mounted drinking fountain may be placed in settings such as: parks, schools, and other facilities where the temperature may drop into freezing conditions. Model meets all current Federal Regulations for the disabled including those in the Americans with Disabilities Act. Haws manufactures drinking fountains, faucets and electric water coolers to be lead-free by all known definitions including NSF/ANSI/CAN 61- Section 9, NSF/ANSI/CAN 372, California Proposition 65, and the Federal Safe Drinking Water Act. Product is compliant to California Health and Safety Code 116875 (AB 1953-2006), and NSF/ANSI/CAN 61: Q ≤ 1.



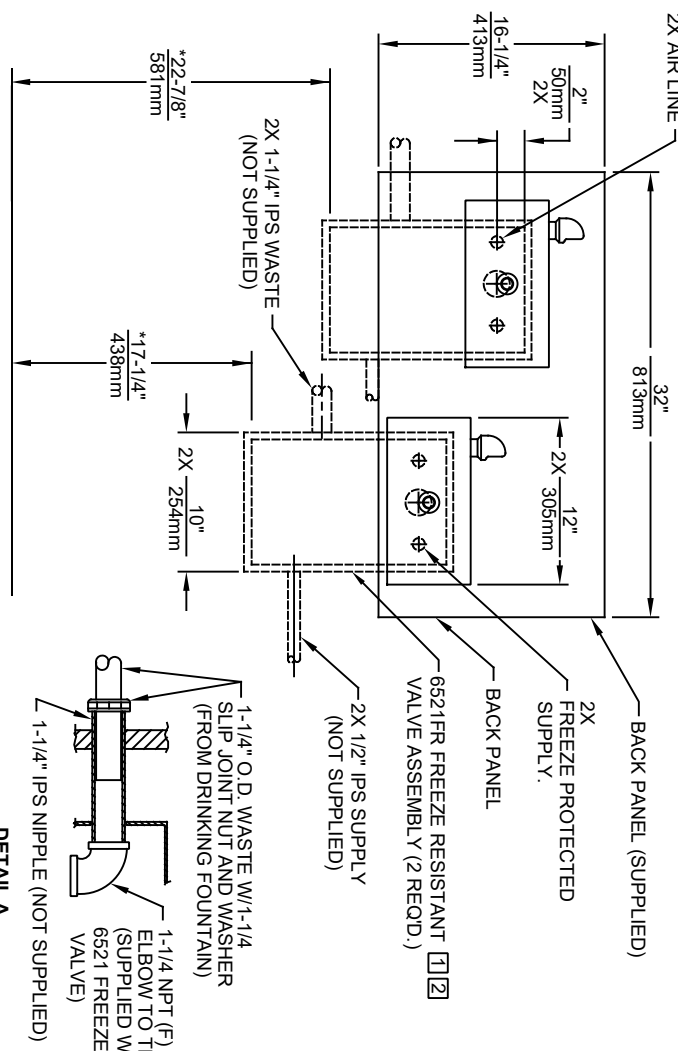
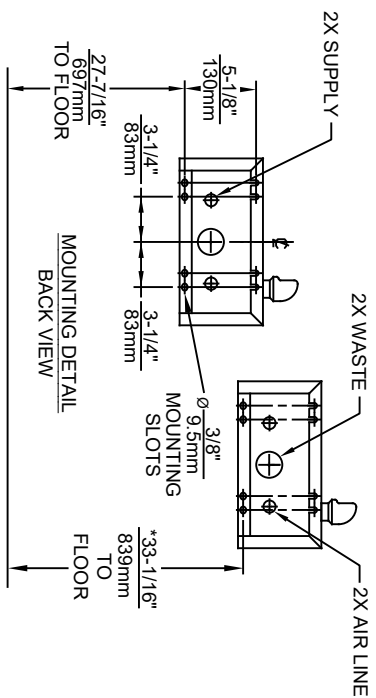
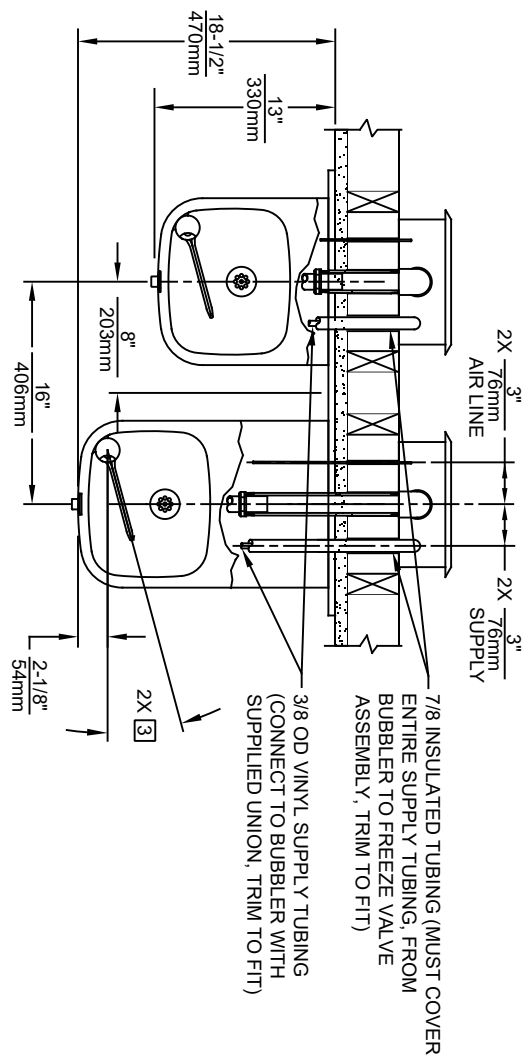

DETAIL A

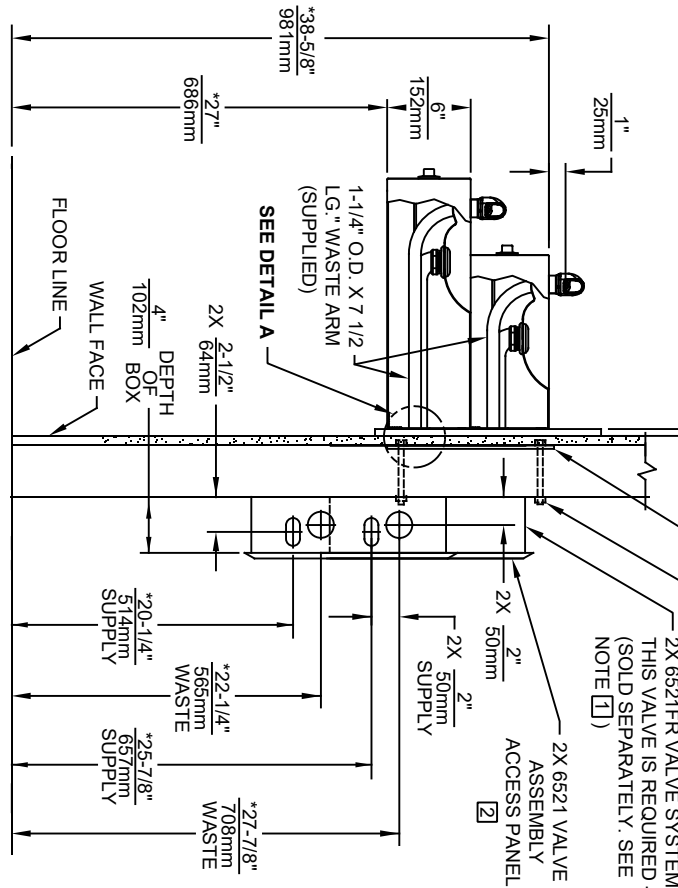

NOTES:

- THIS FOUNTAIN REQUIRES THE USE OF MODEL 6521FR FREEZE RESISTANT VALVE ASSEMBLY (SOLD SEPARATELY OR AS PART OF PRODUCT BUNDLES (E.G., 1199FR WITH TWO 6521FRS OR 1119FR WITH 1920FR (NOT SHOWN) AND THREE 6521FRS). SEE 6521FR INSTALLATION INSTRUCTIONS FOR CONNECTION DETAILS.
- VALVE ASSEMBLY MUST BE INSTALLED IN A WARM AREA. PROVISIONS SHOULD BE MADE TO ALLOW ACCESS TO ACCESS PANEL
- MAXIMUM ADJUSTABLE RANGE IS 15" FROM PARALLEL TO BACK OF WALL.
- HOLD ROUGH-IN DIMENSIONS ± 1/4" (6.4mm).
- WHEN INSTALLING THIS UNIT LOCAL, STATE OR FEDERAL CODES SHOULD BE ADHERED TO. FOR INSTALLATION HEIGHTS OTHER THAN SHOWN, DIMENSIONS MARKED (*) MUST BE ADJUSTED ACCORDINGLY.

Haws

1456 KLEPPE LANE
SPARKS, NEVADA, 89431
(775) 359-4712 FAX (775) 359-7424
E-MAIL: HAWS@HAWSCO.COM
WEBSITE: WWW.HAWSCO.COM

ECN NO. REVISED PER BY:	MODEL(S)
ECN: 5900	1119FR
DATE: 6/10/98	
CHKD: JS	
FELIX V.	
APPROVED: EV	
DATE: 07/08/22	
SCALE: 1:14.5	DRAWING TYPE: INSTALLATION
SHEET: 1 OF 1	

PART NUMBER: 0002076627.D
REVISION: 15