



# Haws®

# model 3202

ADA Outdoor Steel Pedestal Fountain

## FEATURES & BENEFITS

### CONSTRUCTION

Heavy-duty 12 gauge galvanized steel with a green powder-coat finish incorporates a recessed push button and welded bubbler guard to provide extra durability, a large access panel for ease of service, and a vandal-resistant bottom plate for added peace of mind.

### DRAIN FREE

Unique design allows this pedestal fountain to be placed in the harshest of outdoor environments without the worry of a clogged drain. When water is activated, the excess flow runs from its trough basin off the back and onto the ground - perfect for beaches, play grounds, and other areas high in debris.

### BUBBLER HEAD

Polished chrome-plated brass bubbler head with integral basin shank for added strength. Shielded, angled stream opening provides a steady, sanitary source of drinking water at .45 gpm.

### DRINKING FOUNTAIN VALVE

The push-button activated valve offers the only all stainless steel valve body that is machined out of solid bar stock, is fully serviceable through the front of the push button assembly offering access to the water control cartridge and integral water supply strainer, and with front access to the water stream height adjustment for easy maintenance without having to remove the valve. Operating pressure range of 30 to 90 psi (2.1 to 6.2 bar).

### VANDAL-RESISTANT

The bubbler head, push button, and bottom plate are locked in place, discouraging unwanted vandal tampering.

## OPTIONS

- Faucet Valve: Model 6250LF, self-closing, plain end, lead-free, brass bib faucet with polished chrome-plated finish.

For more information, visit [www.hawsc.com](http://www.hawsc.com) or call (888) 640-4297.



## SPECIFICATIONS

Model 3202 barrier-free pedestal drinking fountain shall include a 12 gauge galvanized substrate steel pedestal with green powder coating, push-button operated stainless steel valve with front-accessible cartridge and flow adjustment, 100% lead-free waterways, polished chrome-plated brass vandal-resistant bubbler head backed against a pedestal guard, trough design in the pedestal instead of a waste to eliminate clogging, a 1/4" (.6 cm) spacer to raise the pedestal off the ground which reduces the potential for corrosion, integral mounting feet, and an over-size vandal-resistant access plate.

## APPLICATIONS

Perfect for either public or private settings, the trough style fountain is a great fit in areas more prone to drain clogging. Completely eliminating the need for a traditional fountain drain, trough fountains are a nice complement to outdoor environments where a gravel fill can be implemented. Heavy-duty steel and green powder-coated finish make for a solid freestanding design that will hold up and blend in with the environment. More specifically, this fountain is applicable in forest/campground environments as well as parks, schools, and other outdoor areas where drinking facilities are needed. Model meets all current Federal Regulations for the disabled including those in the Americans with Disabilities Act. Haws manufactures drinking fountains, faucets and electric water coolers to be lead-free by all known definitions including NSF/ANSI/CAN 61-Section 9, NSF/ANSI/CAN 372, California Proposition 65, and the Federal Safe Drinking Water Act. Product is compliant to California Health and Safety Code 116875 (AB 1953-2006), and NSF/ANSI/CAN 61: Q ≤ 1.



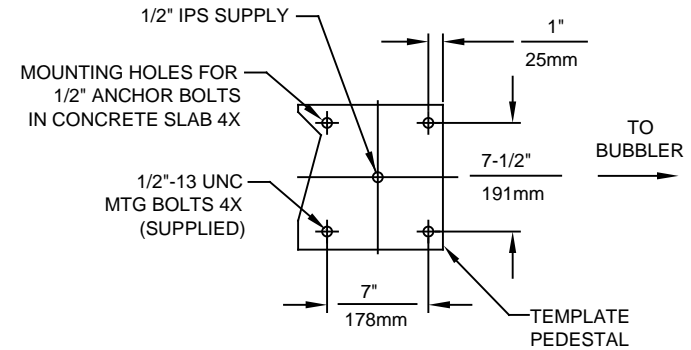
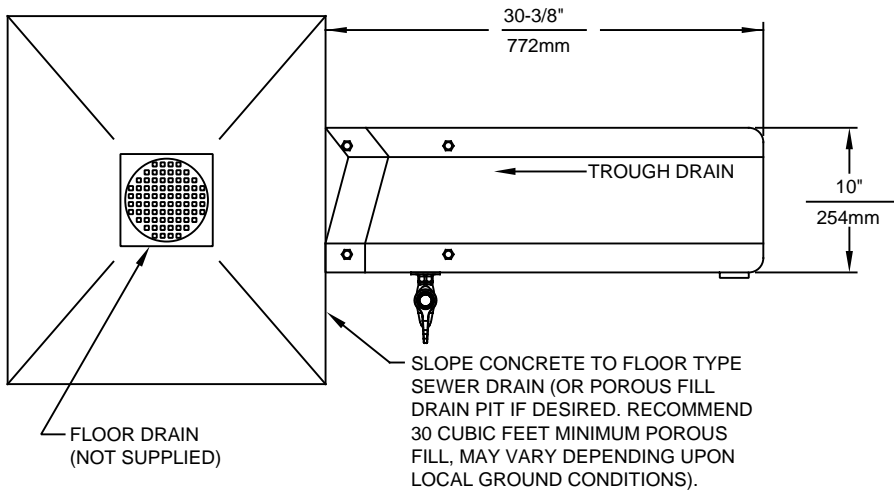

**MOUNTING DETAIL**

**IMPORTANT: ATTENTION INSTALLER**

USE CARE TO AVOID KINKS WHEN ROUTING SUPPLY LINE TO VALVE AND FROM VALVE TO BUBBLER

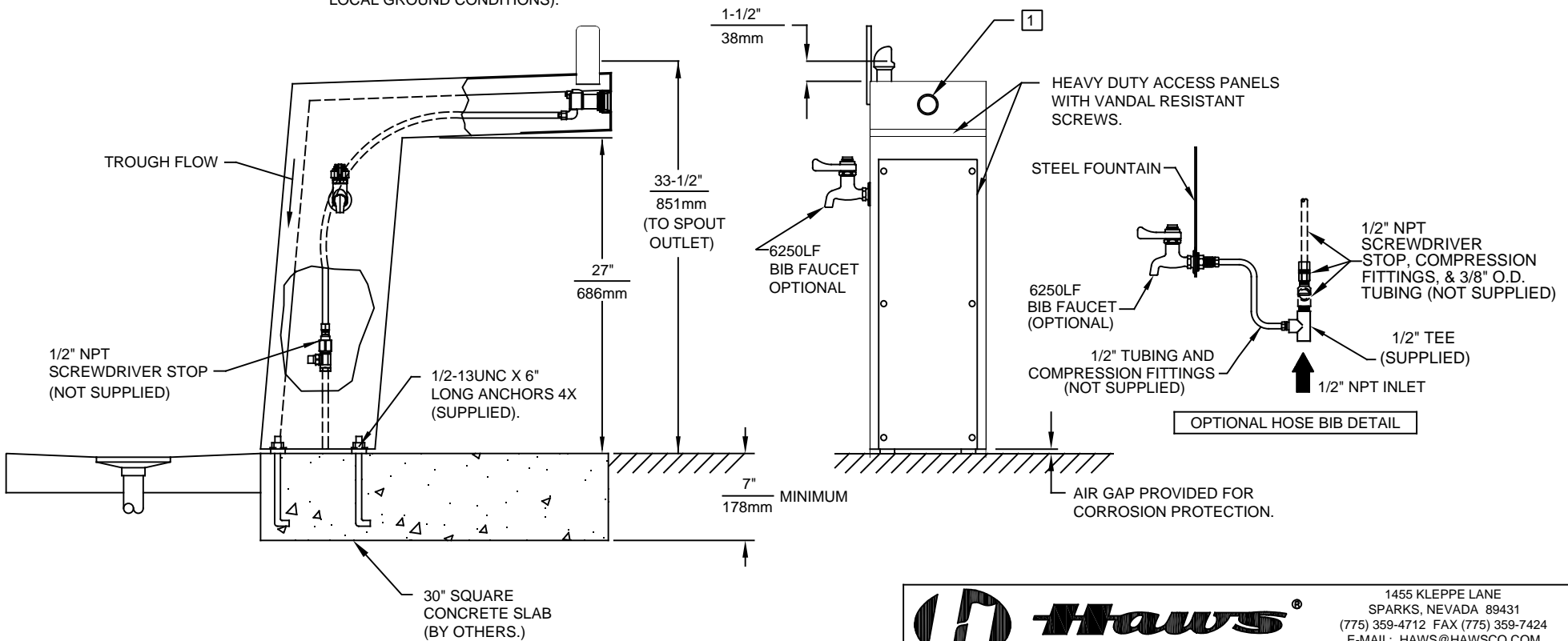

**NOTES:**

1 REFER TO 5874 SERIES OPERATION AND MAINTENANCE MANUAL FOR PUSH BUTTON AND VALVE INSTALLATION/MAINTENANCE INSTRUCTIONS.

1455 KLEPPE LANE  
SPARKS, NEVADA 89431  
(775) 359-4712 FAX (775) 359-7424  
E-MAIL: HAWS@HAWSCO.COM  
WEBSITE: WWW.HAWSCO.COM

ECN NO.	REVISED PER	BY:	MODEL(S)	PART NUMBER
	ECN: 5265	JP		0002077328.D
DRAWN:	DATE:	CHKD.:		REVISION
C. HAYES	11/91	GC	3202/3202G	25
APPROVED:	DATE:	SCALE:	DRAWING TYPE:	SIZE:
FV	02/23/18	1:14	INSTALLATION	A
			SHEET	1 OF 1