

NNEBFEZ

Cooler to Bottle Filler Conversion Kit for Single and Split Level
ELKAY EZ8 and LZ8 Water Coolers

INSTALLATION INSTRUCTIONS

Section 1: Getting Started

What's Included:

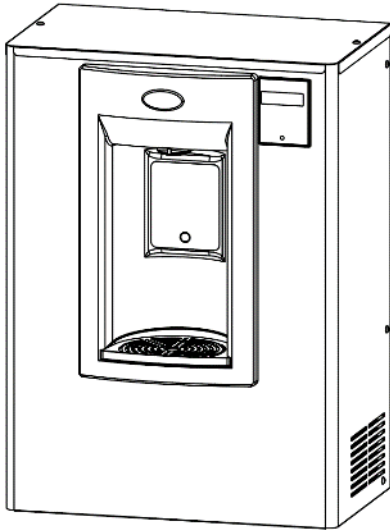

Assembled NNEBFEZ
Cabinet



1/4" Elbow



1/4" Union



0.25" Terminals
x2



10" of 1/4" OD plastic
tubing with 9" of tubing
insulation

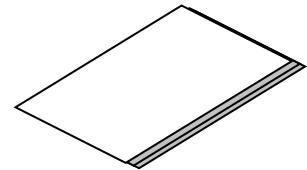

Installation
instructions

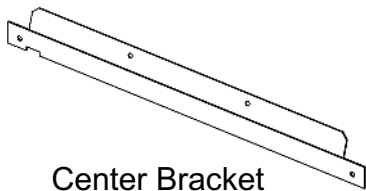

Center Bracket



Drain Elbow
x2

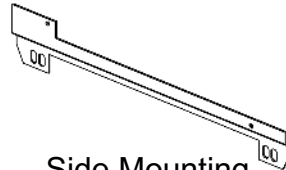

Side Mounting
Bracket
x2

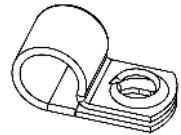

Strain Relief
P-Clip



Drainpipe
x2

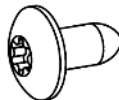

#8 Torx Screws
x3



#10 Hex Screws
x6

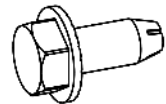

#8 Thread Cutting
Hex Screw

Tools & Hardware Required:

- Electric drill/driver
- Small tubing cutter for plastic line
- 5/16" nut driver
- 1/4" nut driver
- Means to cut 1 1/4" drain pipe
- T15 Torx screwdriver or bit
- T20 Torx screwdriver or bit
- 4 appropriate wall anchors (not supplied)

Section 2: Rough In Drawing

NNEBFEZ:

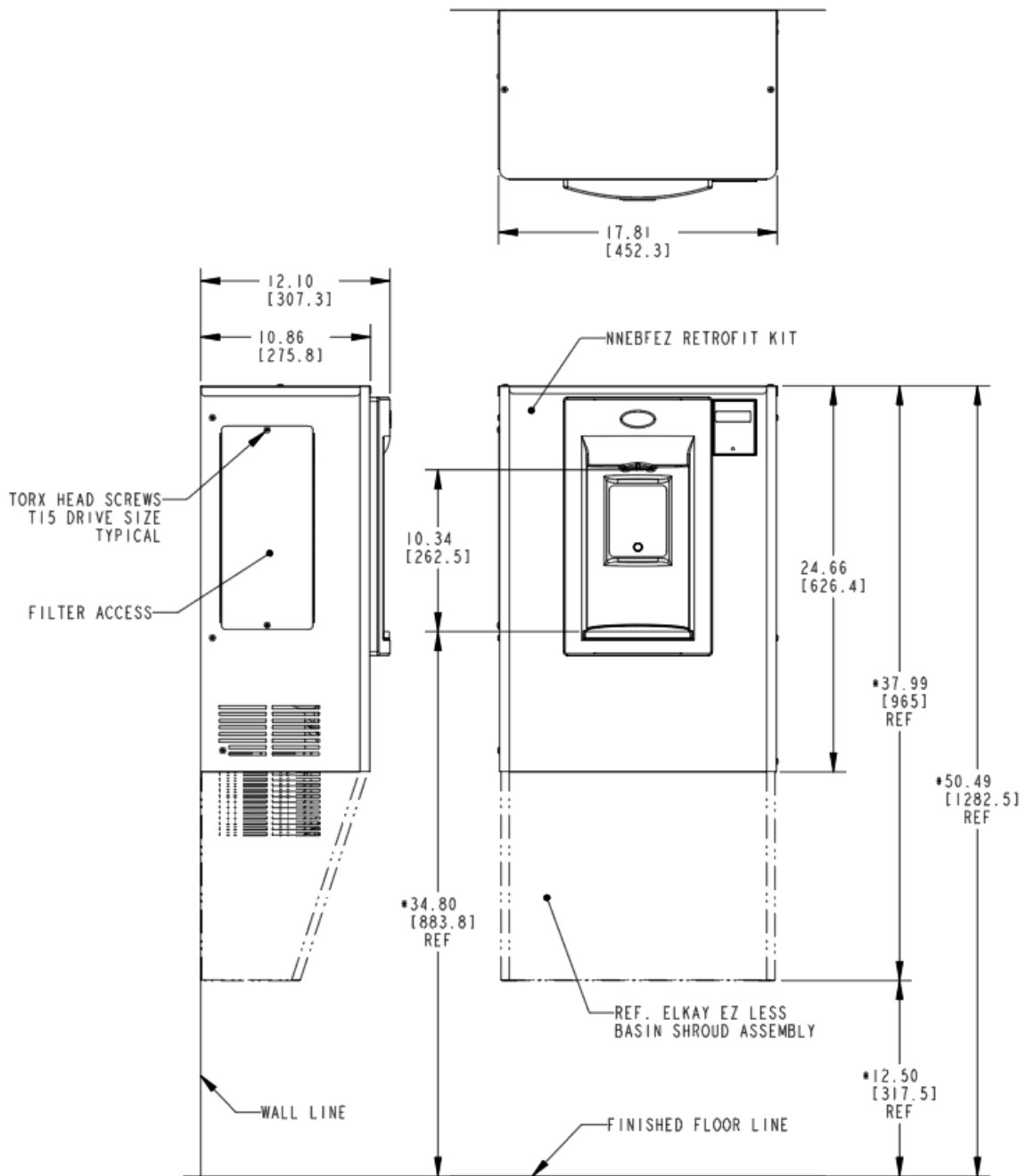

NOTES:

1. * DIMENSIONS ARE REFERENCE ONLY.

2. ALL DIMENSIONS ARE IN INCHES.
DIMENSIONS IN BRACKETS [] ARE MILLIMETERS.

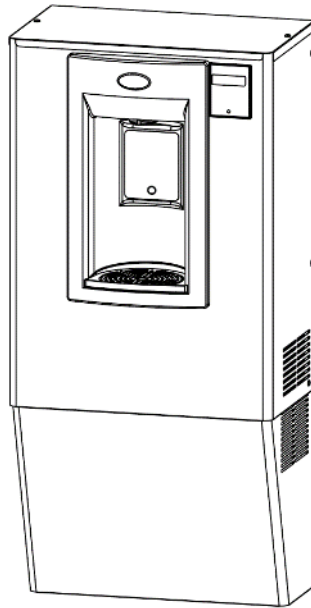

SINGLE LEVEL PREPARATION

- **Disassembly of ELKAY Cooler**
- **Wiring**
- **Water Lines**

Section 3: Preparation

1. Remove fountain wrapper.

2. Turn OFF water supply to the unit.
Bleed any remaining pressure from the lines by activating the bubbler valve.

3. Disconnect power by UNPLUGGING the unit from the wall socket.

Remove 4x
#10 Hex
Screws

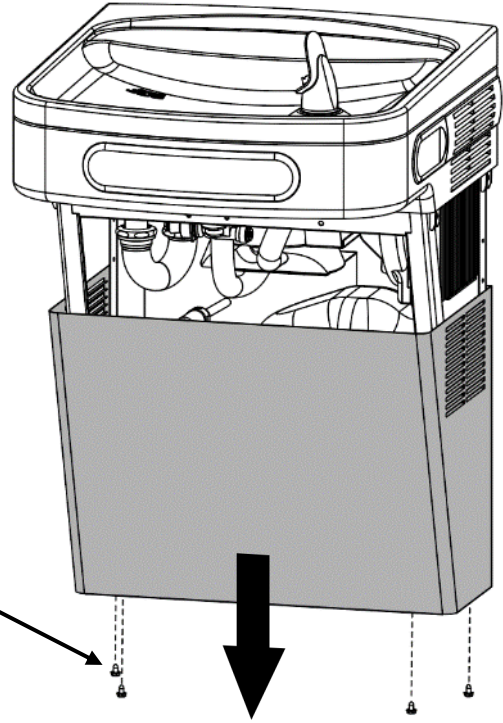

4. Loosen or remove the P-trap so that the fountain nose assembly may be freely removed in the next step.

Loosen or
Remove

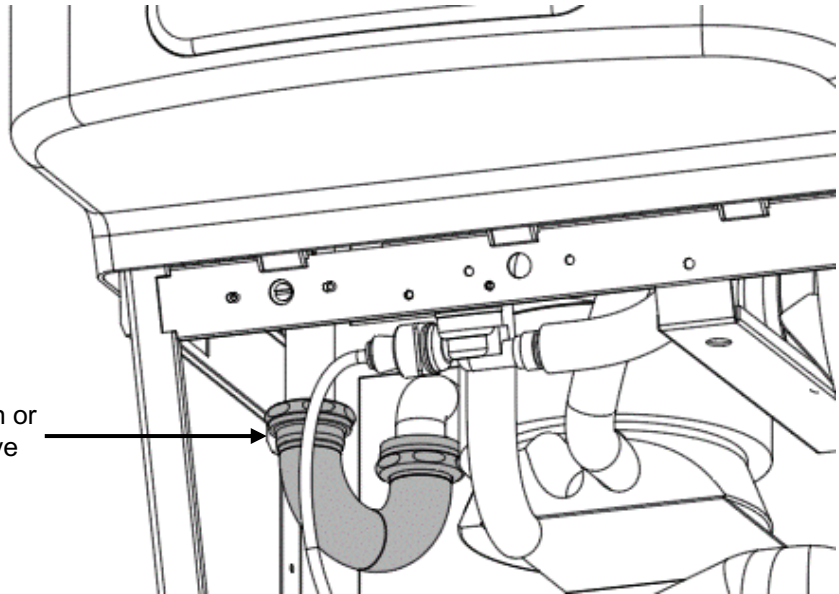

Section 3A: Preparation

5. Remove fountain nose assembly. **Tool Needed: T20 Torx bit**

- A. Remove 4x #10 Torx screws from the fountain.
- B. Disconnect **ONLY** the nose assembly wires from the cold control and solenoid valve. Leave all other wires connected to the cold control and solenoid valve. For non-refrigerated models, unplug the unit.
- C. Disconnect the water line from the bubbler inside the nose. **DO NOT** disconnect from the fountain.

DO NOT REMOVE COLD CONTROL OR SOLENOID VALVE ASSEMBLIES FROM THE FOUNTAIN.

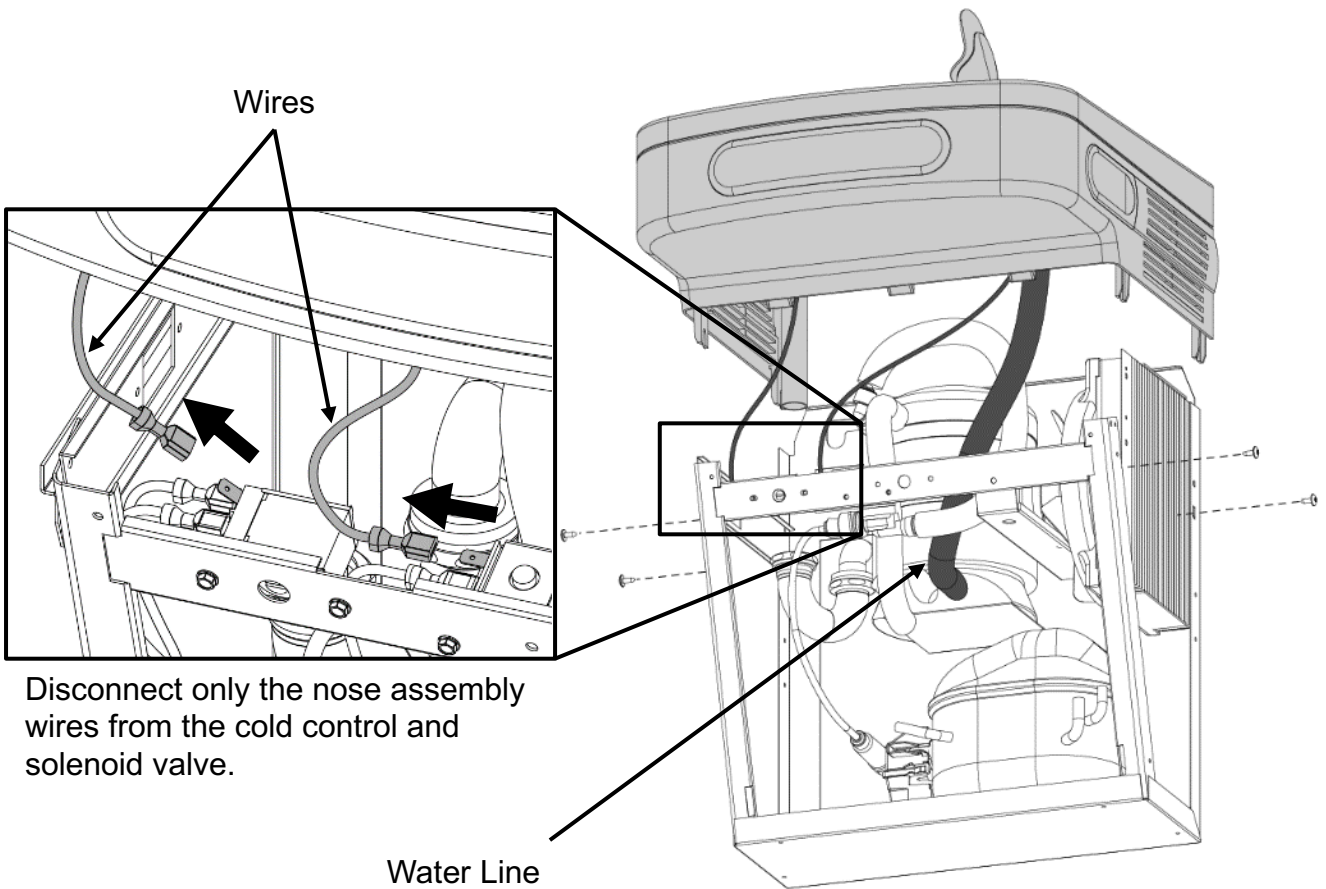

Section 3A: Preparation

6. After the nose assembly has been removed, cover the two bare terminals with the insulated female spade terminals (provided) for safety.

NOTE: The image shown may differ from some models but the instructions will still apply.

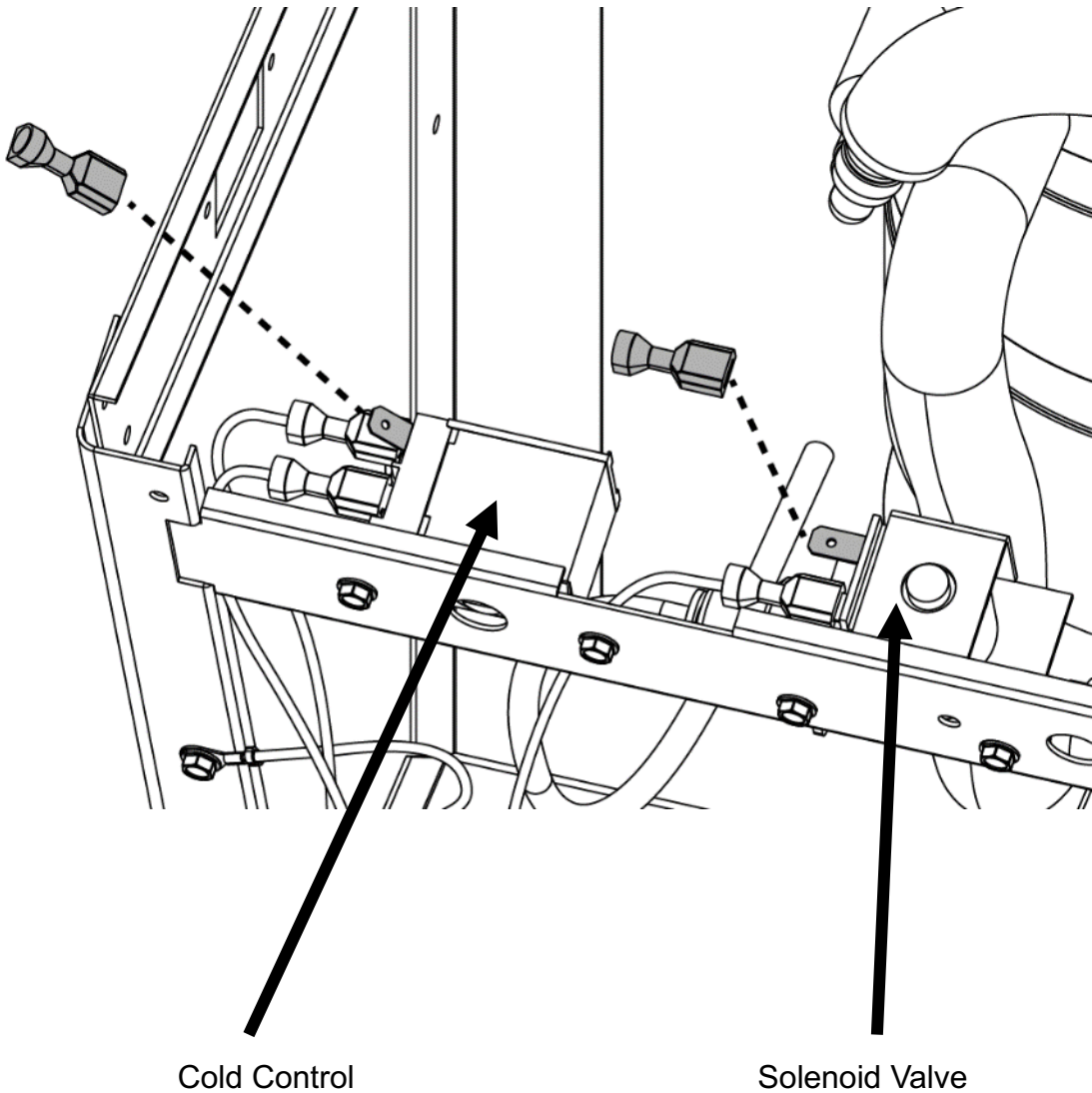

Section 3A: Preparation

7. Locate the solenoid valve on the Elkay unit. Disconnect both water lines from the solenoid valve. Join the two water lines together using a $\frac{1}{4}$ " elbow fitting (provided) (Fig. 7A).

Allow the cooling tank water outlet line to extend freely upward (Fig. 7B).

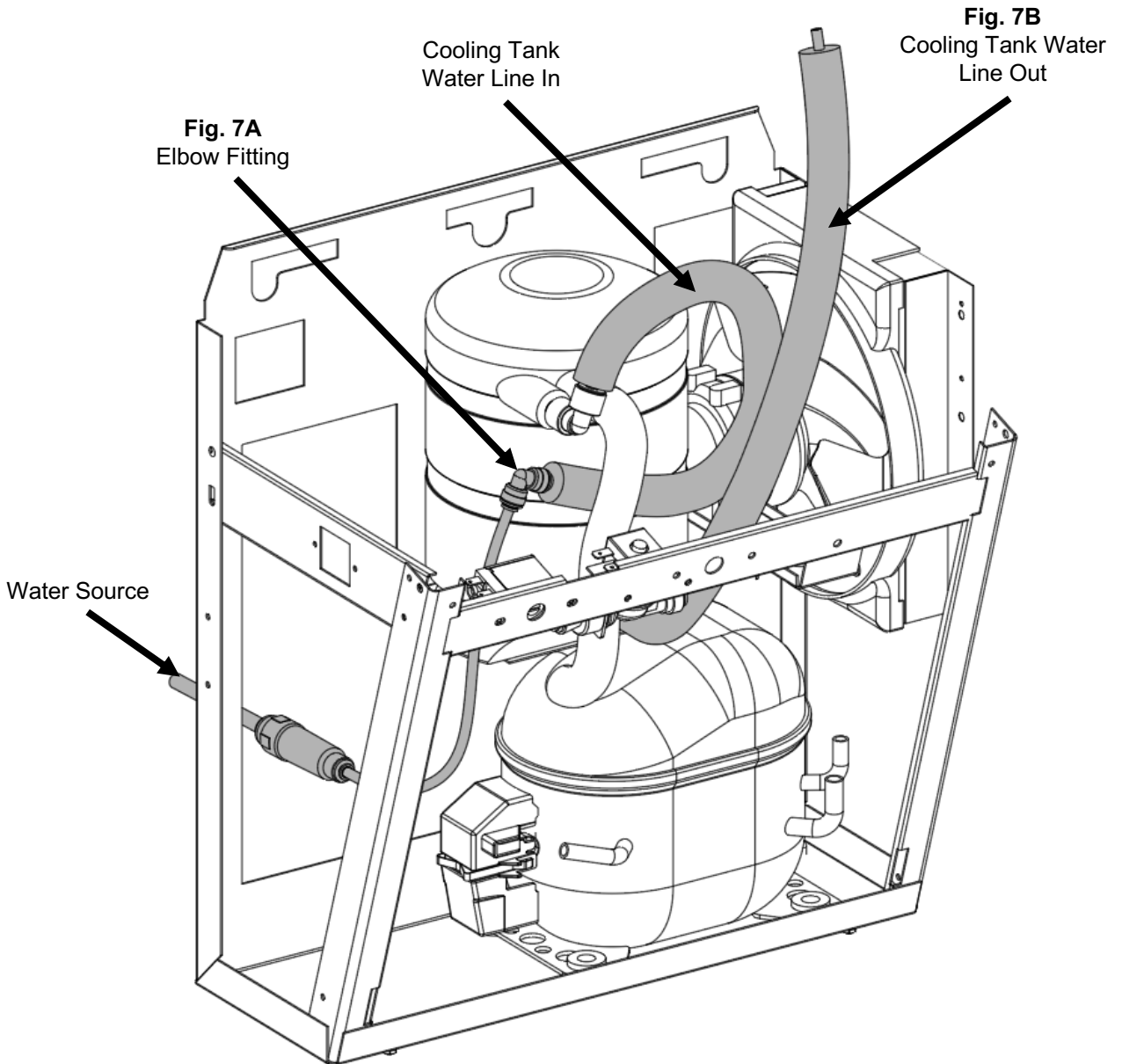

Shown above is the correct final orientation

SINGLE LEVEL INSTALLATION

- **Assembly of NNEBFEZ Cabinet**
- **Wiring**
- **Plumbing**

Section 4: Installation

1. The NNEBFEZ comes partially assembled for shipping. Remove the kit from the packaging and separate it into the assemblies and components shown below. **Be sure not to misplace the provided mounting screws and insulated terminals.**

Tool Needed: T15 Torx bit

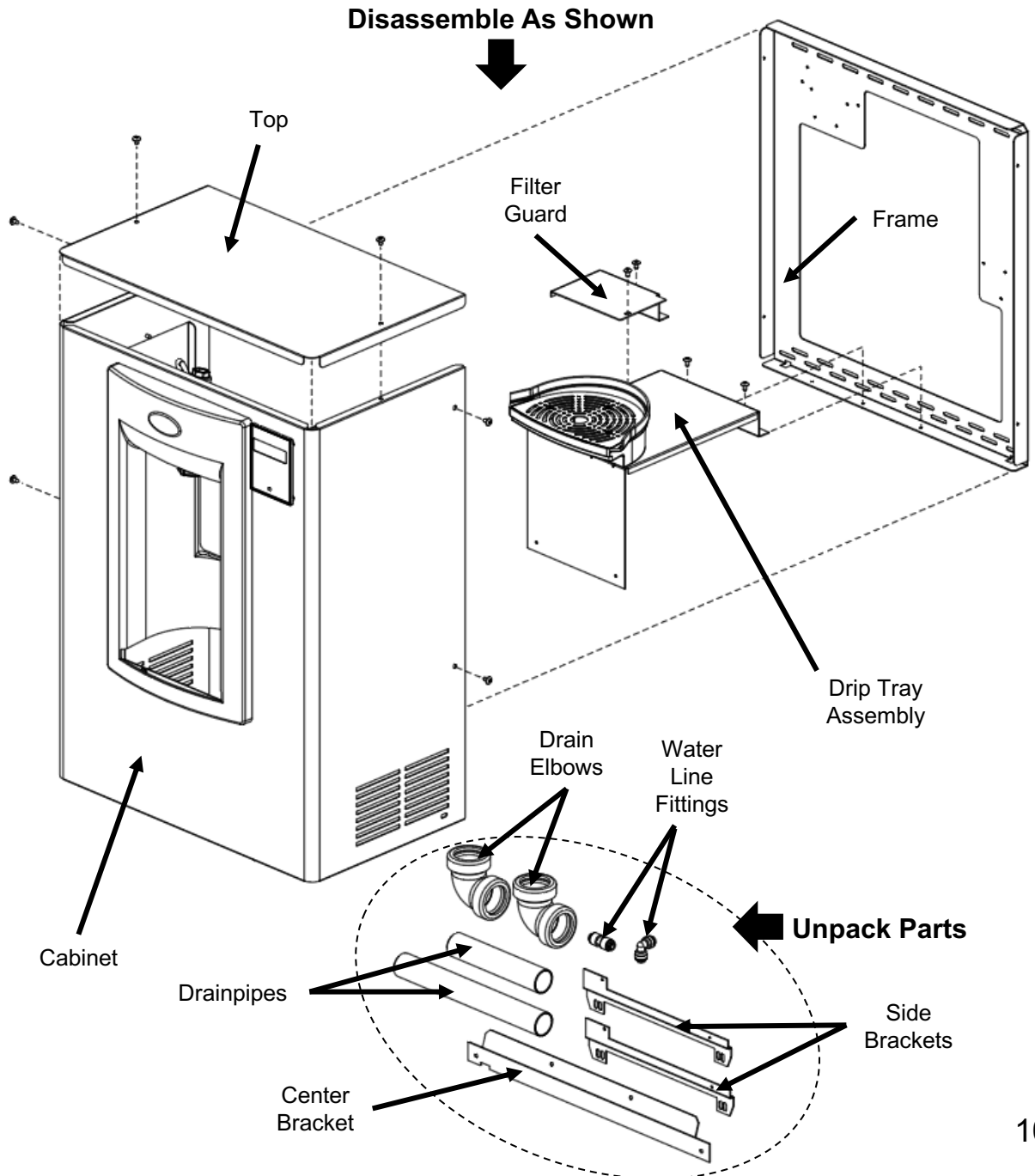

Section 4: Installation

- Without taking the cooler off the wall, place the retrofit frame against the wall and set it onto the top flange of the cooler frame.

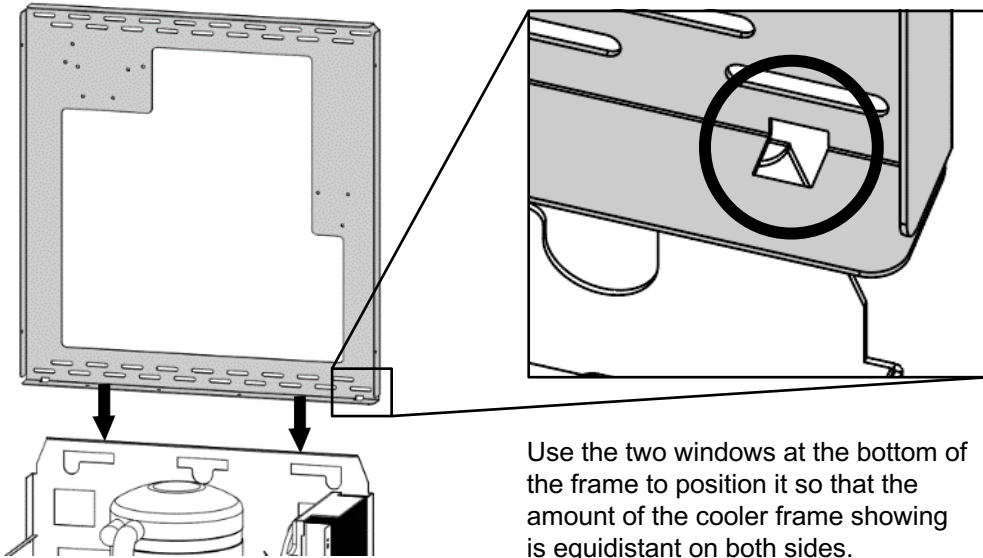

- Affix the frame to the wall with at least 4 anchors into any appropriate anchor points through the staggered slotted holes. **Be careful to ensure the frame stays centered on the cooler frame.**

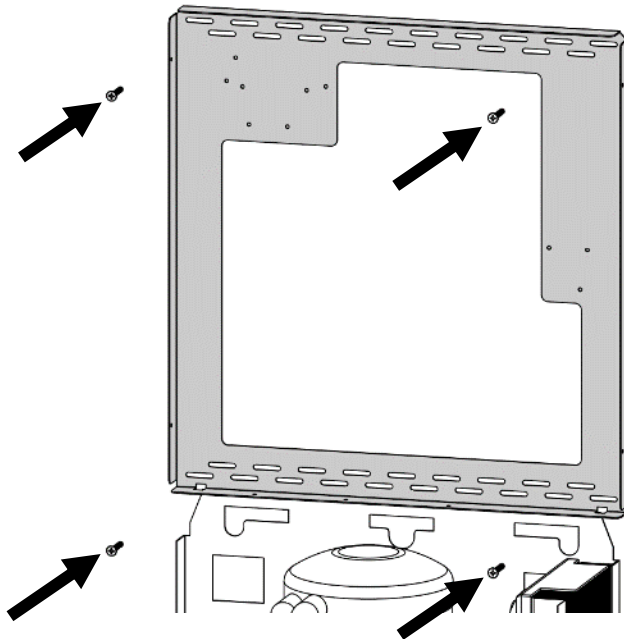

Not Provided. Use appropriate screws/ Anchors for mounting surface.

Section 4: Installation

4. Assemble the center bracket to the holes in each of the cooler struts.

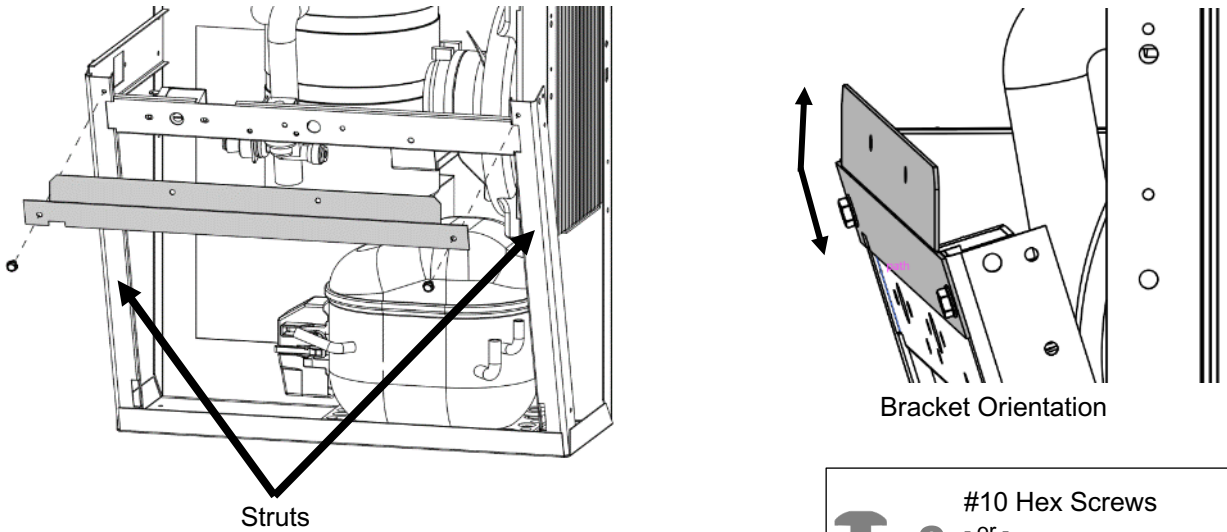

Tx2 #10 Hex Screws
- or -
#10, T20 Torx Screws
(original to fountain unit)

5. Assemble the two side brackets to the cooler frame using the slotted holes on the bottom with two #10 screws for each bracket. Ensure that the brackets are oriented as shown below.

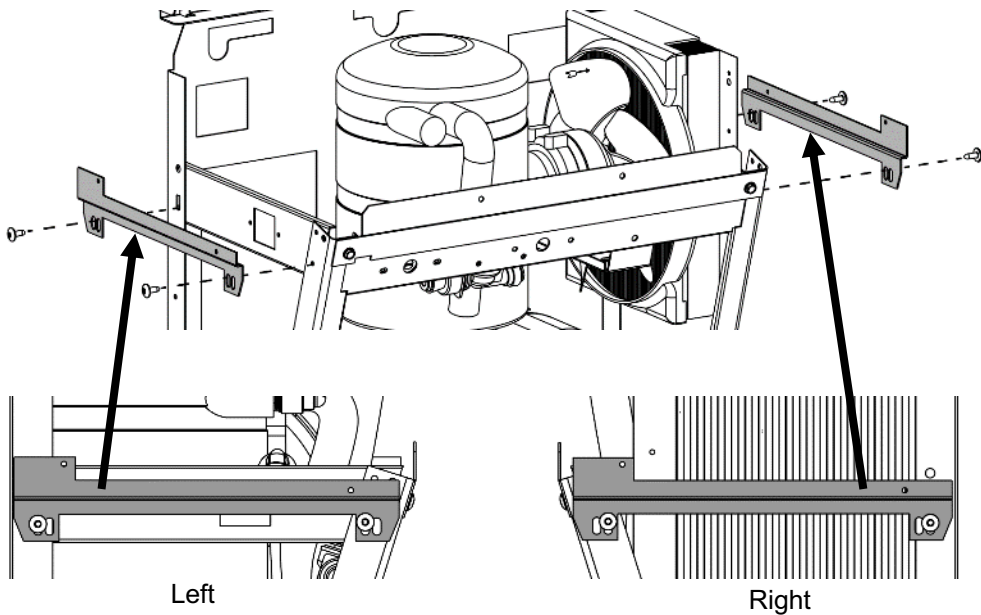

Tx2 #10 Hex Screws (each bracket)
- or -
#10, T20 Torx Screws (each bracket)
(original to fountain unit)

Section 4: Installation

6. Install the drip tray support bracket (keep drip tray pre-assembled) to the center bracket and frame using 4x, #8 Torx screws which are provided in the kit.

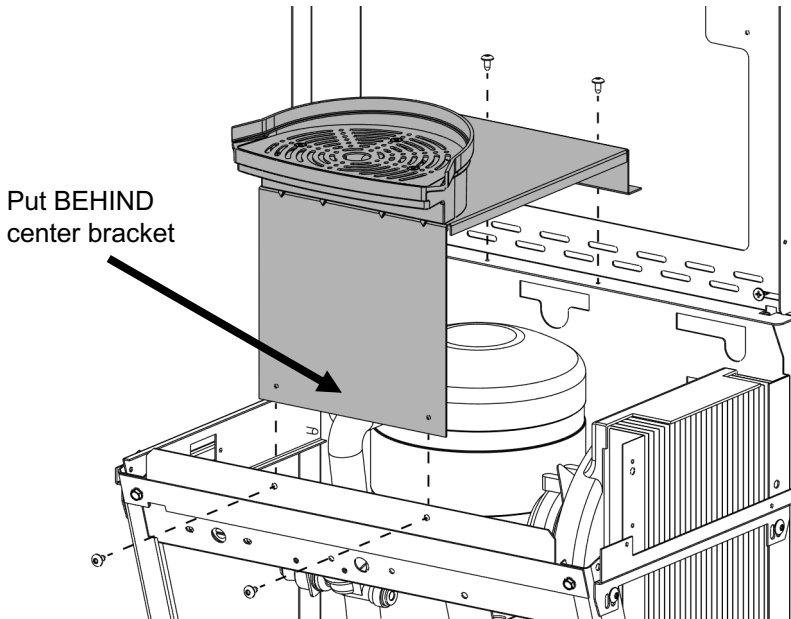

Tx4 #8, T15 Torx Screws

7. Attach the filter guard bracket with 2x, #8 Torx screws to the frame and drip tray support bracket. This bracket helps to prevent the filter cartridge from falling into the cooler unit below during installation or replacement.

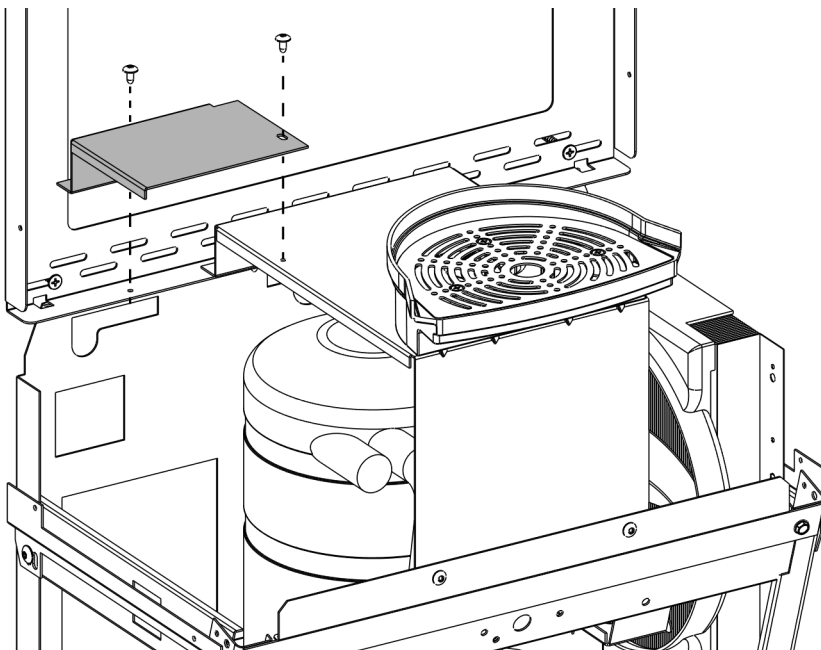

Tx2 #8, T15 Torx Screws

Section 4: Installation

8. Attach one of the drain elbows to the drip tray stem. Insert the drainpipe provided into the elbow and then attach another elbow onto the pipe. Use the remaining drainpipe and connect the drip tray drainage system to the installed P-trap.

NOTE: Drainpipes will need to be positioned and cut to length as needed.

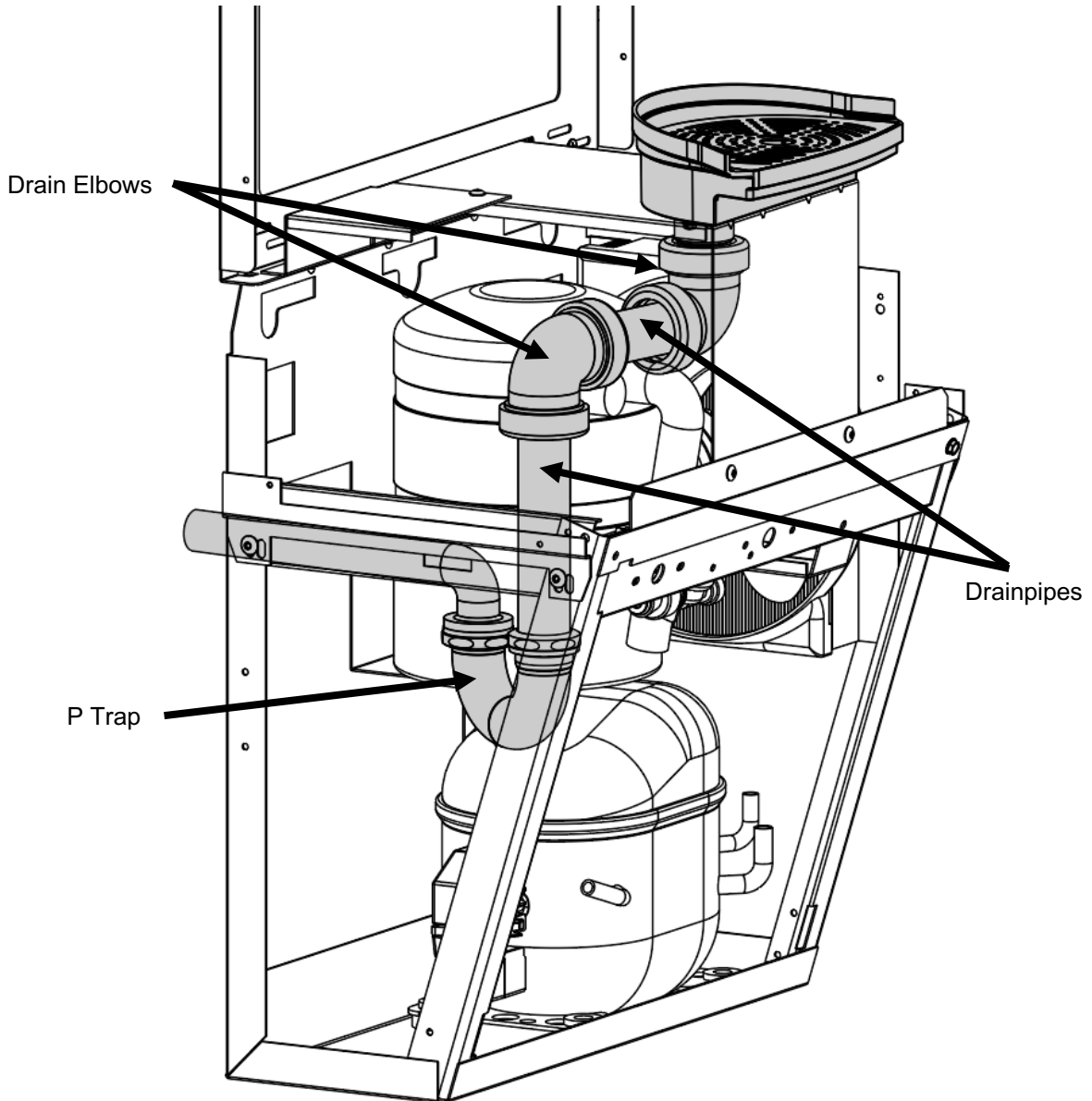

Section 4: Installation

9. Assemble NNEBFEZ wrapper to the installed frame. Rest the alcove on the drip tray and ensure the wrapper walls rest OUTSIDE of the frame and side brackets.

NOTE: The drip tray will hold the weight of the wrapper but it is recommended to keep a hold on the unit during installation for safety.

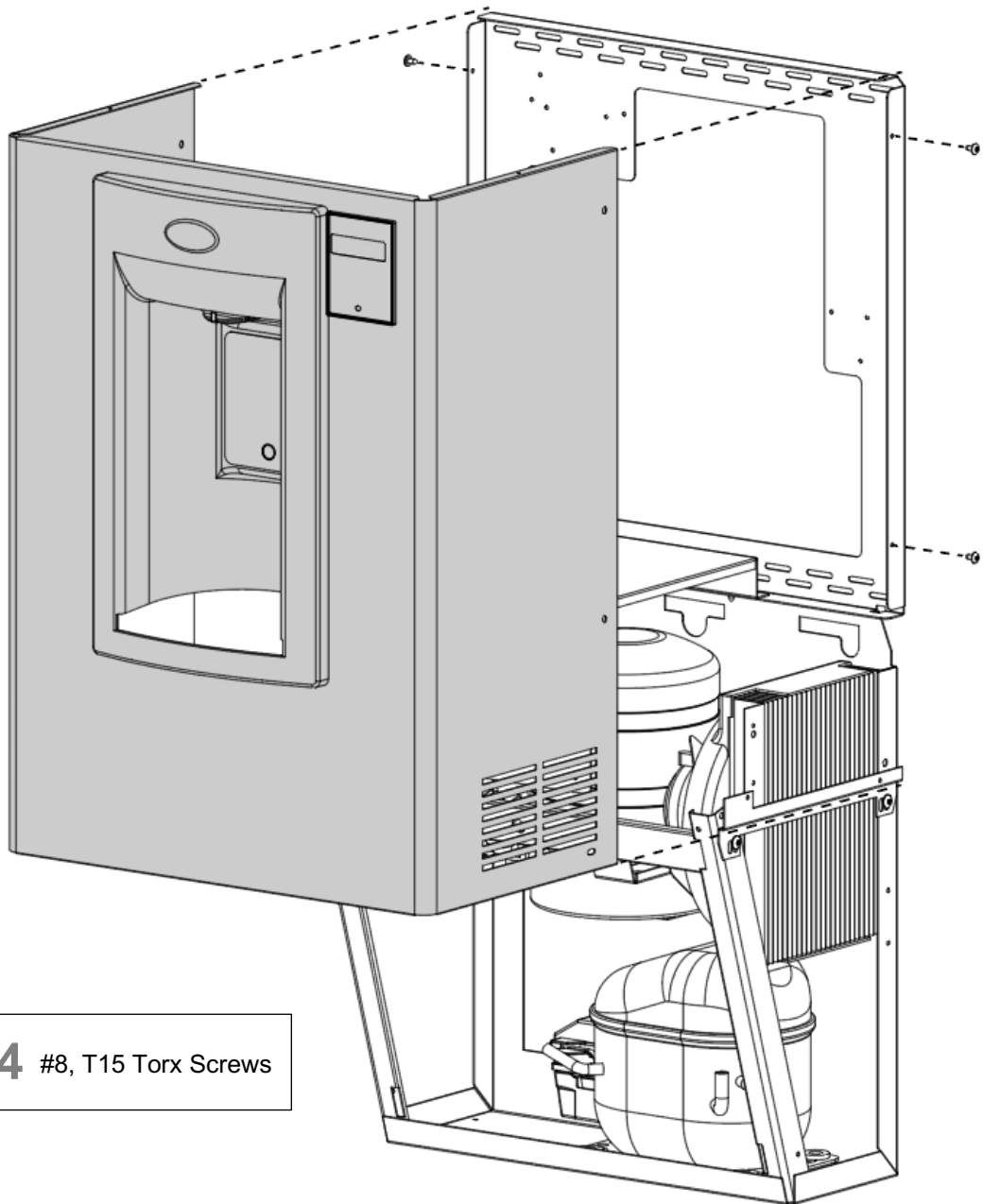

Tx4 #8, T15 Torx Screws

Section 4: Installation

10. If the outer edge of the drip tray is not properly aligned, loosen the screws on the back of the drip tray support bracket and slide the bracket forward or backward as needed. Then retighten the screws.

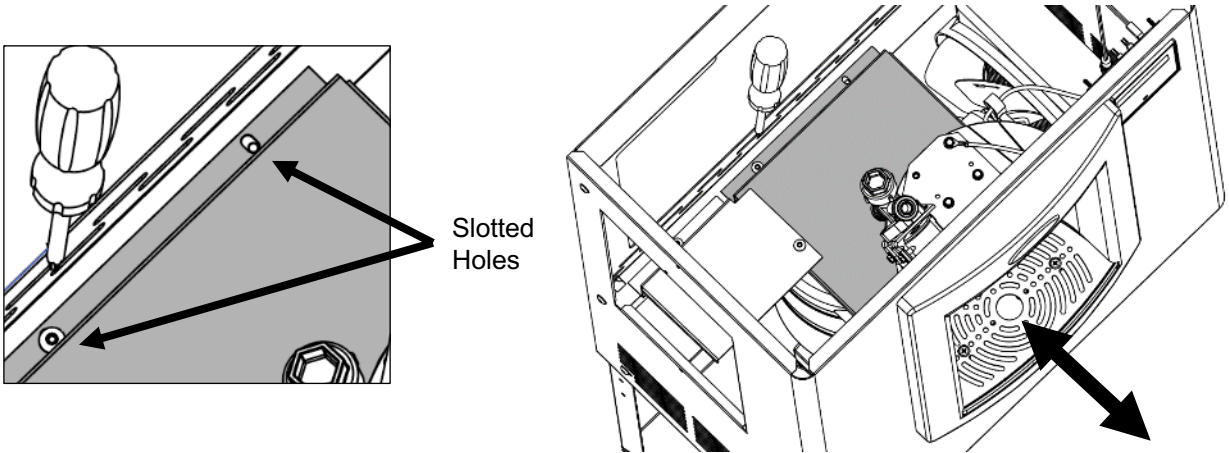

11. Once the wrapper has been installed, loosen the side bracket mounting screws until the bracket can be slid up and down. Adjust the bracket until the mounting hole screws through the slot and then drive in one of the #8 Torx screws and then tighten the two #10 mounting screws.

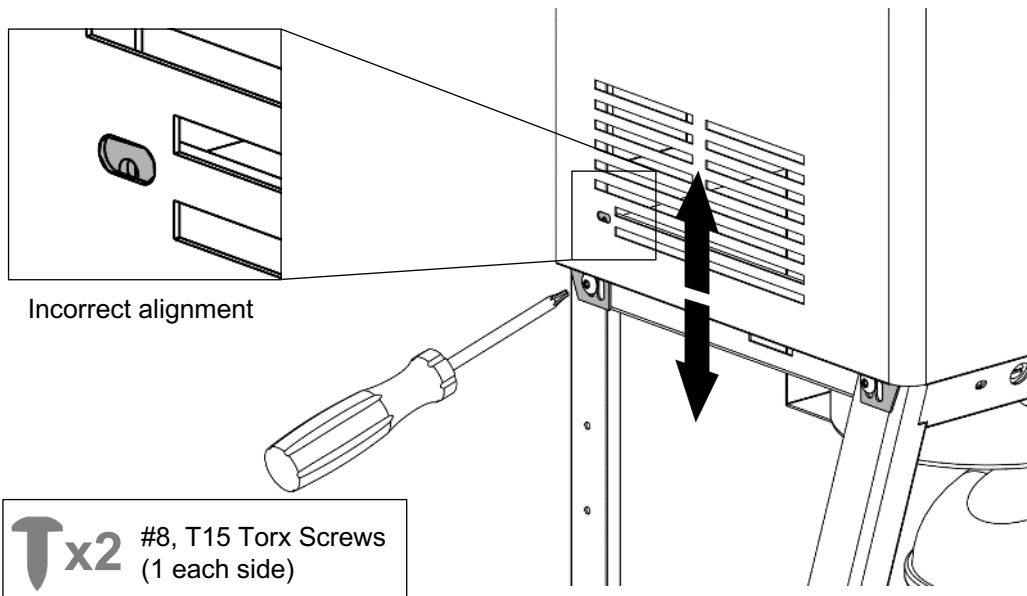

Section 4: Installation

12. Attach the $\frac{1}{4}$ " union fitting to the Cooling Tank water line out (Fig 12A).
13. Attach one end of the provided $\frac{1}{4}$ " water line with insulation tubing to the solenoid valve located on the alcove, and the other end to the $\frac{1}{4}$ " union fitting. Cut provided water line and insulation tubing as needed.

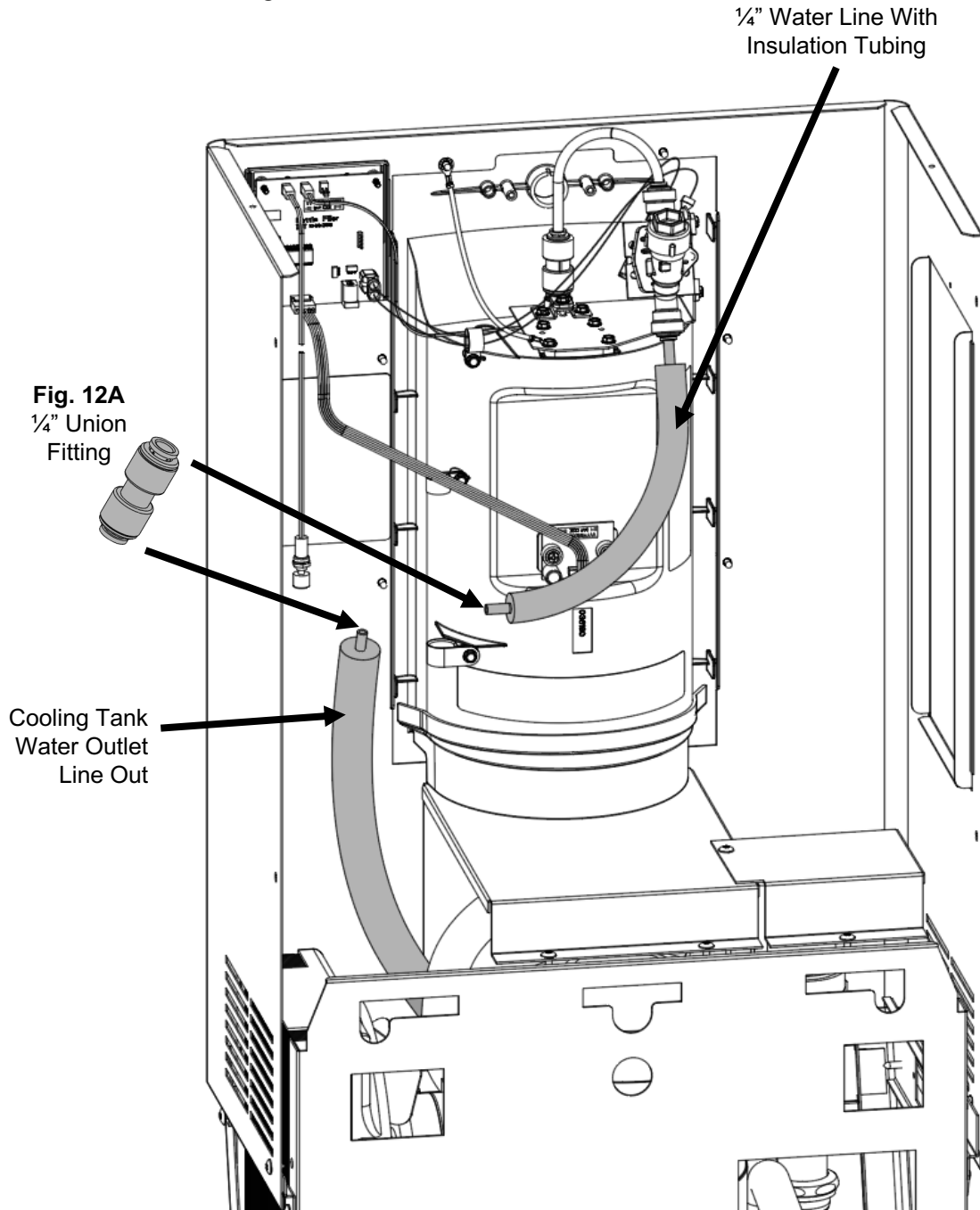

Section 4: Installation

14. Guide the power cord down to the lower portion of the cooler. Ensure that the power cord does not become entangled with other components and ensure that the IEC connector is firmly installed into the power brick.

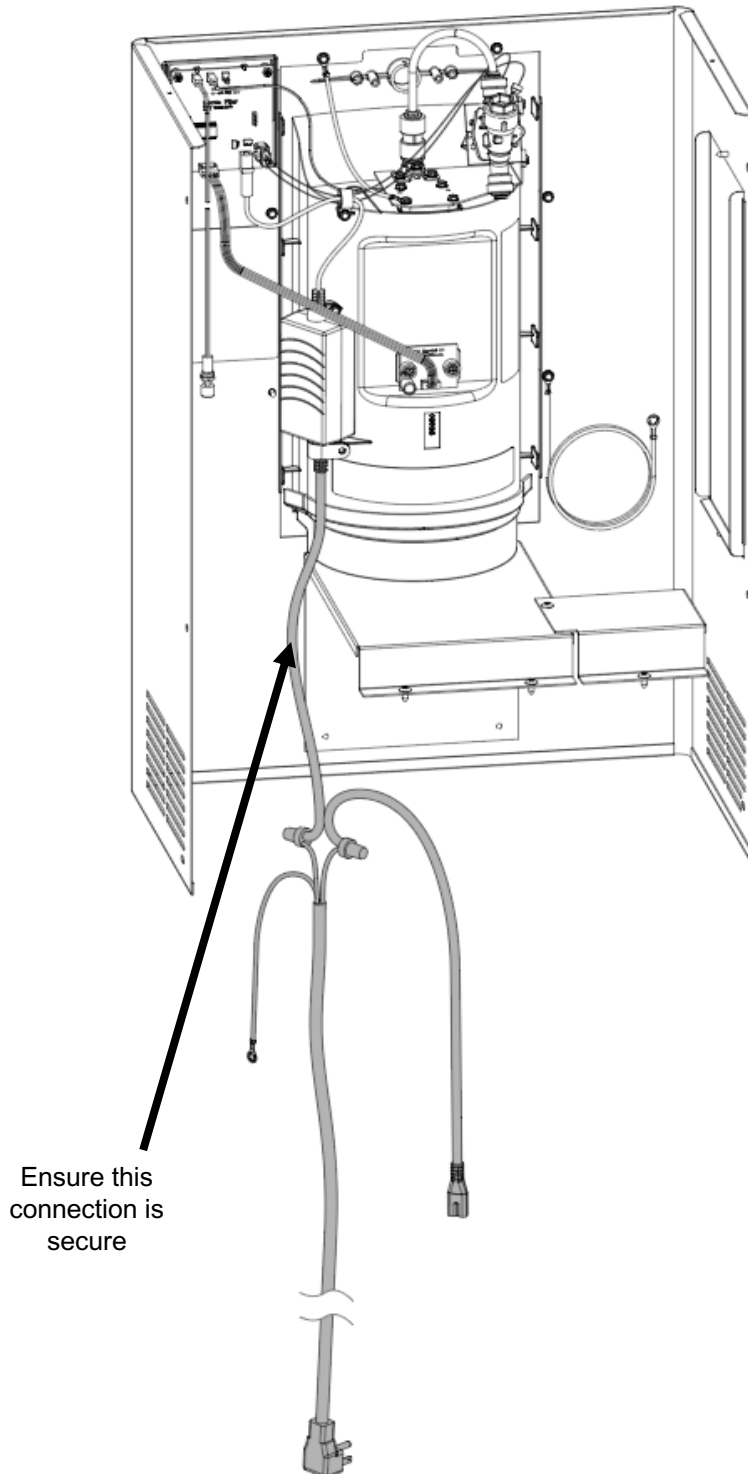

Section 4: Installation

15. Install the provided strain relief P-Clip to the power cord roughly 36" from the grounded plug. Attach it to the back side flange of the fountain frame with a #8 Torx screw. **(Figure 14a)**
16. Attach the ring terminal to the ground screw on the left side of the fountain strut through the lower flared hole using the provided #8 thread cutting hex Screw. **(Fig 15a). Do not remove/alter the original ground.**
17. Finish by plugging in the grounded plug into the duplex socket.

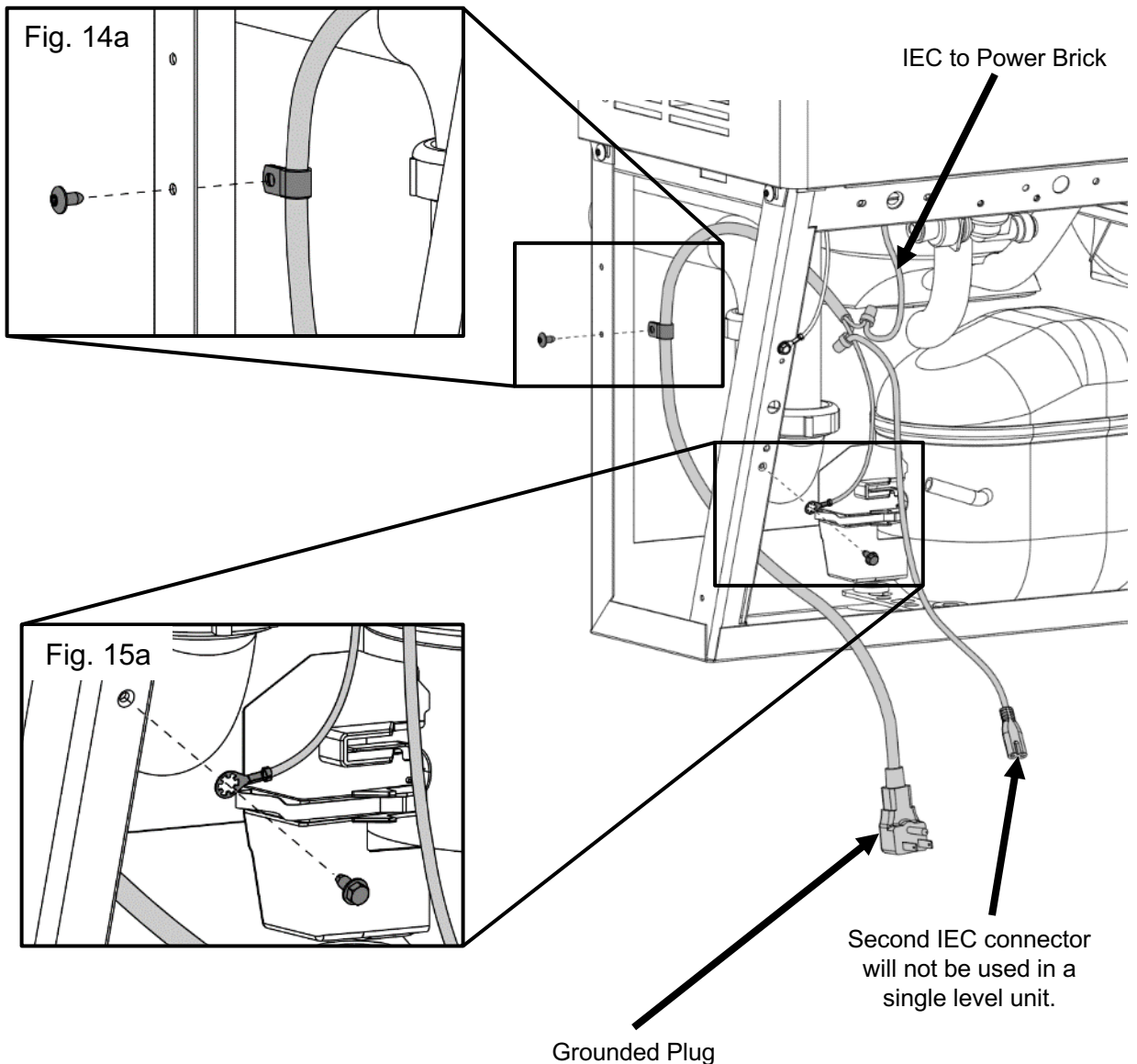

Section 4: Installation

17. Turn on water supply and check for any leaks.
18. Ensure that nothing is obstructing the fan blade.
19. Plug the Elkay power cord into the wall outlet.
20. Test the contactless bottle filler by placing a water bottle into the alcove of the bottle filler. Check for leaks.
21. Install the cabinet top panel, filter access panel and Elkay cooler wrapper.
22. The NNEBEFEZ comes pre-programmed from the factory. For programming options, please refer to **page 34**.

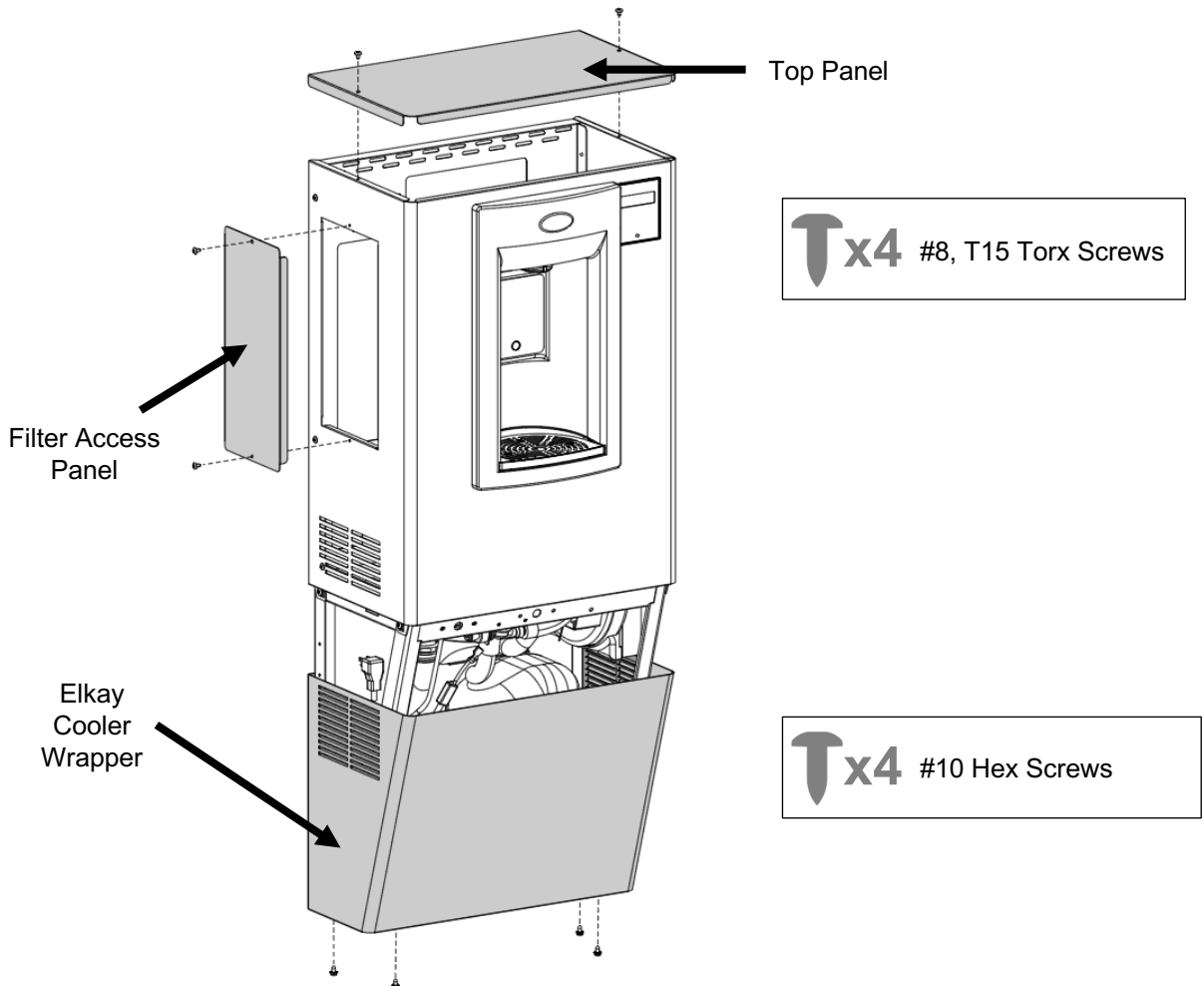

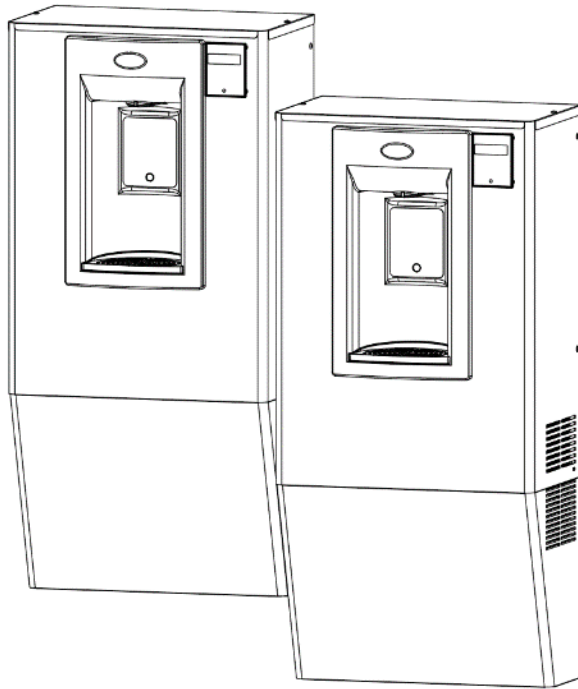

SPLIT LEVEL INSTALLATION

- **Assembly of Split Level NNEBFEZ Cabinet**
- **Wiring**
- **Plumbing**

Section 5: Rough In Drawing

NNEBFEZ Split Level: Left Side or Right Side High

REQUIRES 2X NNEBFEZ UNITS

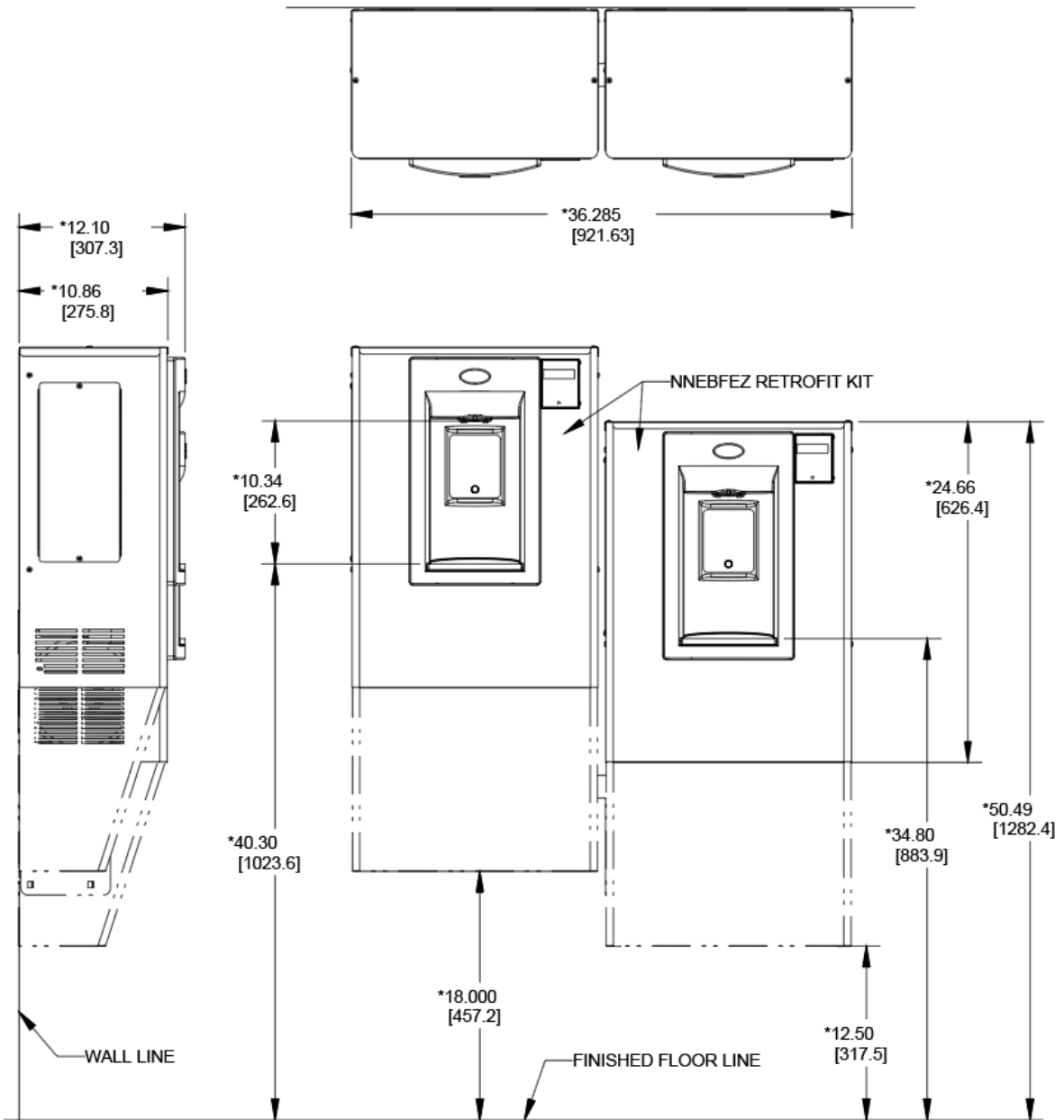

NOTES:

1. * DIMENSIONS ARE REFERENCE ONLY.
2. ALL DIMENSIONS ARE IN INCHES.
DIMENSIONS IN BRACKETS [] ARE IN MILLIMETERS.

Section 6: Split Level Preparation

1. Remove the fountain wrappers and noses from each unit as shown on **pages 5-6** to prepare the units for the NNEBFEZ installation. Unplug **BOTH** units and shut off their water source.

Cover any bare terminals. Refer to **page 7**.

2. Begin split level assembly by disconnecting and removing any drainpipes except for the p-trap and disconnecting the water lines between the fountain units. **Ensure water to the units has been turned off.**
3. Since the split level fountain cold tank is already pressurized, disconnect all water lines from the solenoid valves in both the refrigerated and dummy unit. Do not discard any water tubing.

ORIGINAL CONFIGURATION

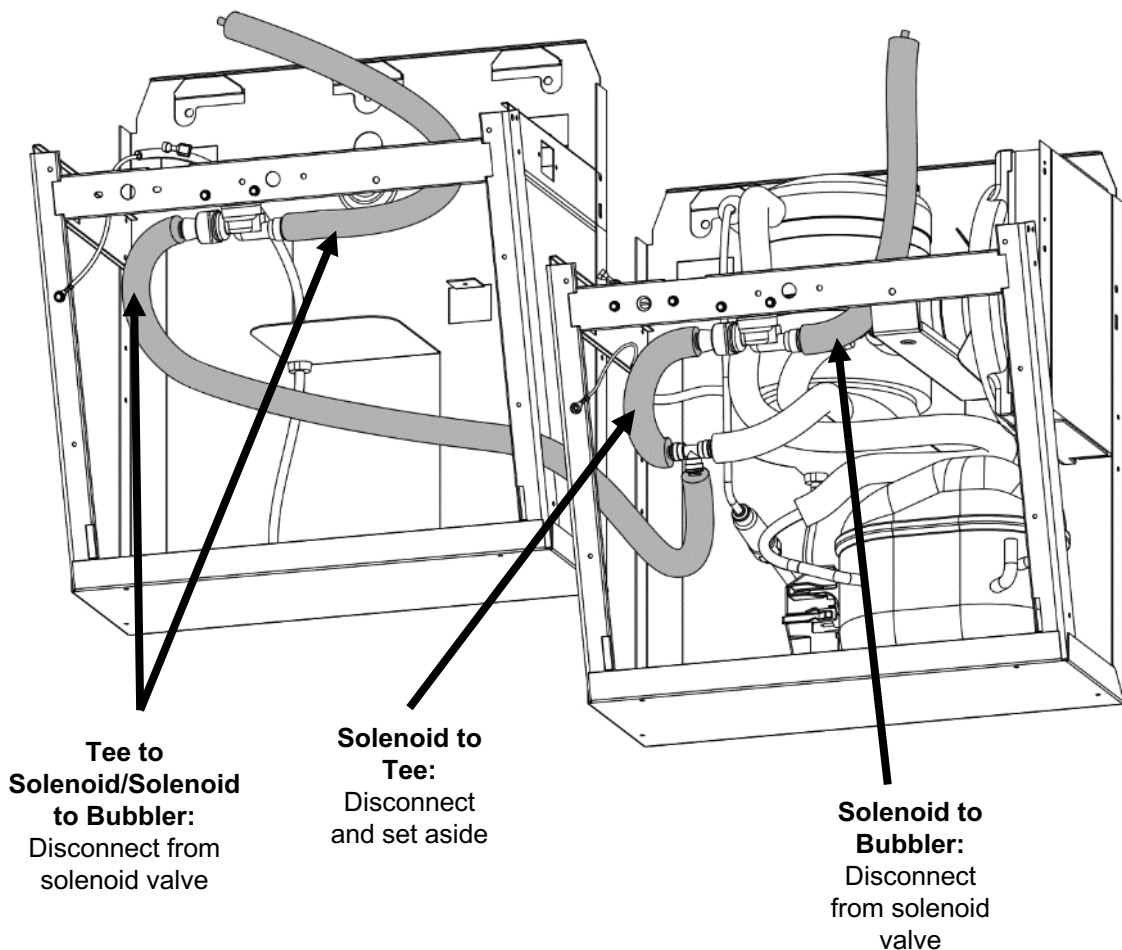

Section 6: Split Level Preparation

4. The final result should have the water line from the cold tank water outlet connect to the tee and split off to the dummy unit and up to the top of the refrigerated unit.

NNEBFEZ CONFIGURATION

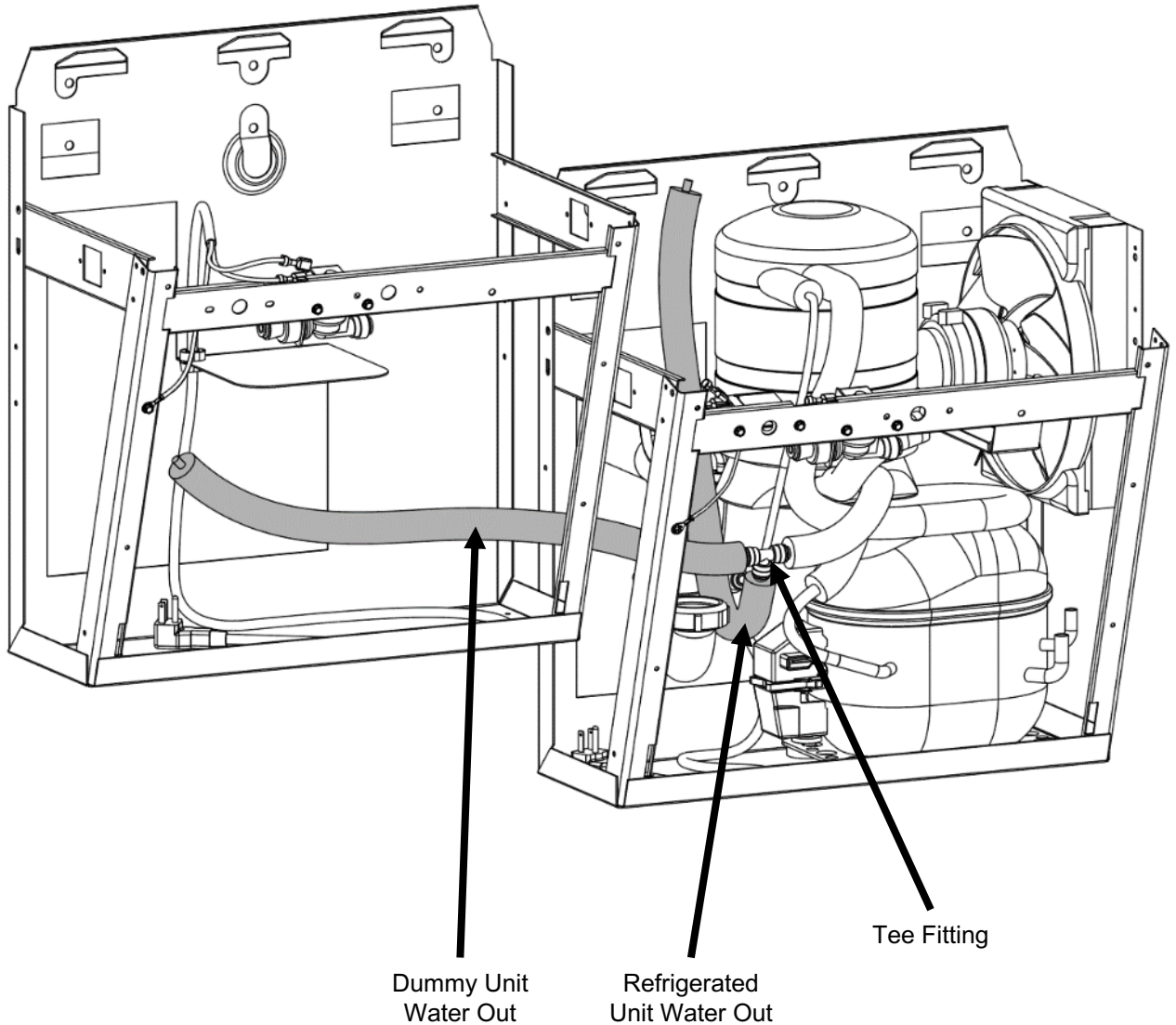

Section 6: Split Level Preparation

5. Set the frame from the second NNEBFEZ kit onto the top of the dummy unit frame and mark the location for each all anchor. **PRE-DRILL** the holes for your chosen anchors (not included).

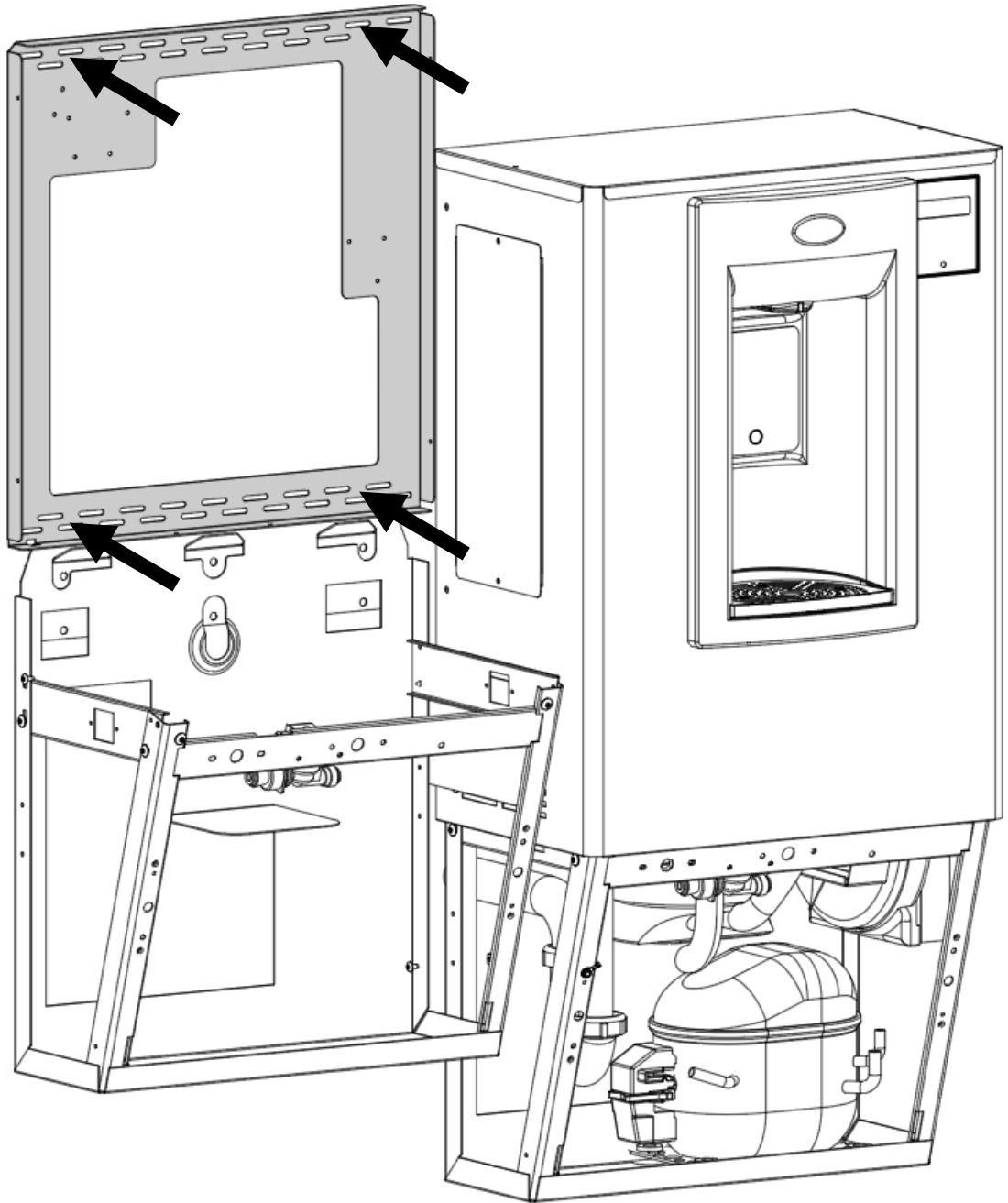

Section 7: Installation

6. Remove the dummy unit from the wall hanger and place it out of the way. Completely assemble a NNEBFEZ to the **refrigerated side first (Refer to pages 10-17)**.

Follow all steps on page 14 with the provided drain supplies, but do not connect to the P-trap or other existing pipes.

Note: The fountain frame may be secured by two anchors at the lower corners. Remove the anchors and set aside until the unit is ready to be reinstalled to the wall.

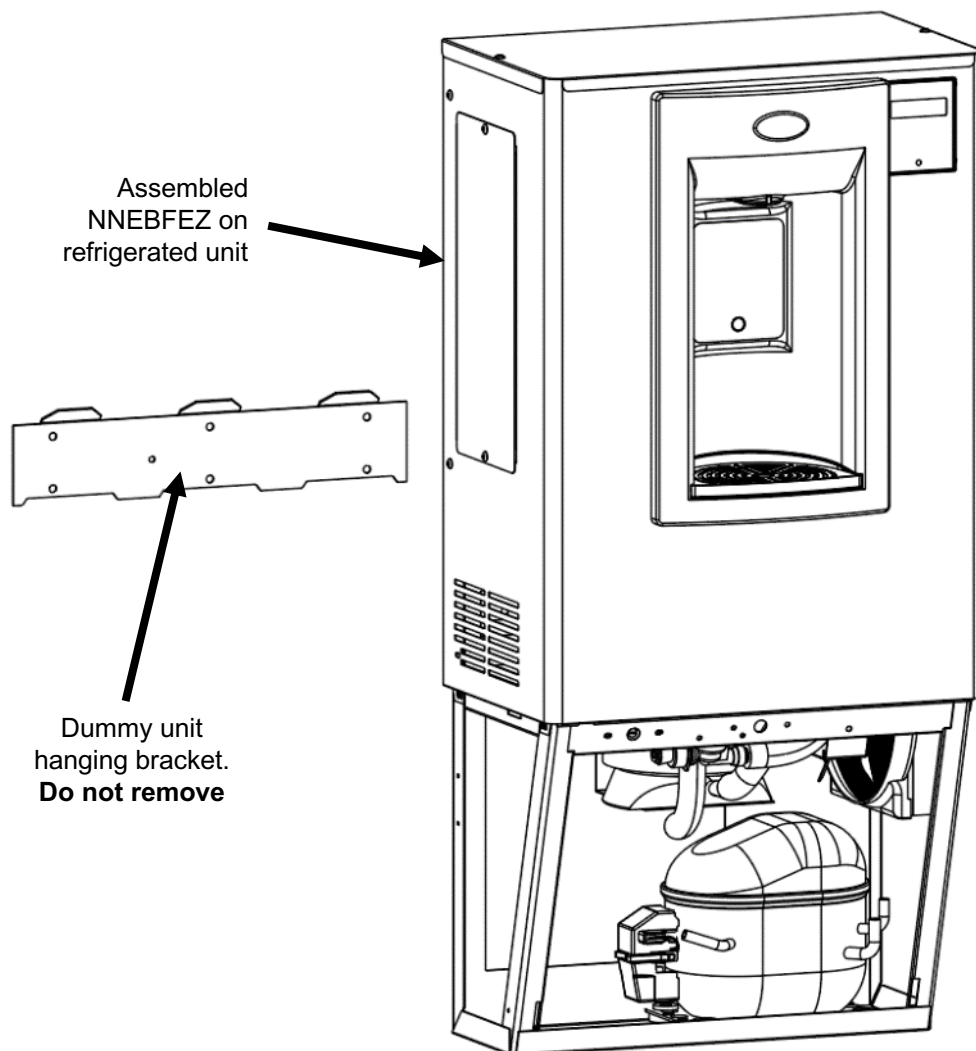

Section 6: Installation

7. Take the second NNEBFEZ out of the carton and prepare the unit as shown on **page 10**. Assemble the side brackets and center bracket to the dummy unit. **Refer to page 12.**
8. Lay the dummy unit on the floor and position the frame so that it sits on the top flange of the fountain frame, then assemble the drip tray assembly bracket to the unit. **Refer to page 11.** It is recommended that the filter guard bracket is not installed in this step.

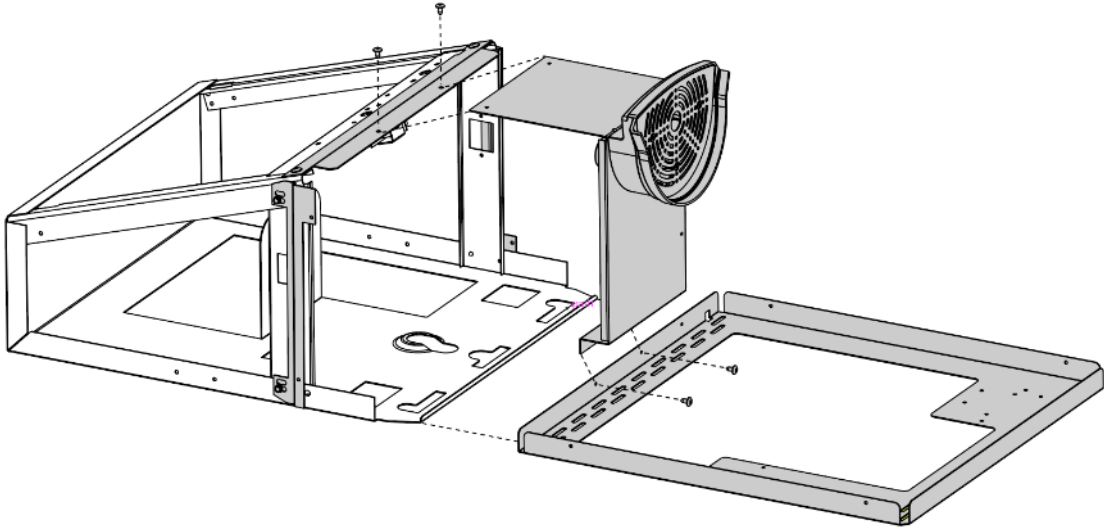

9. Assemble the provided drain elbows and short drainpipe to the drip tray drain.

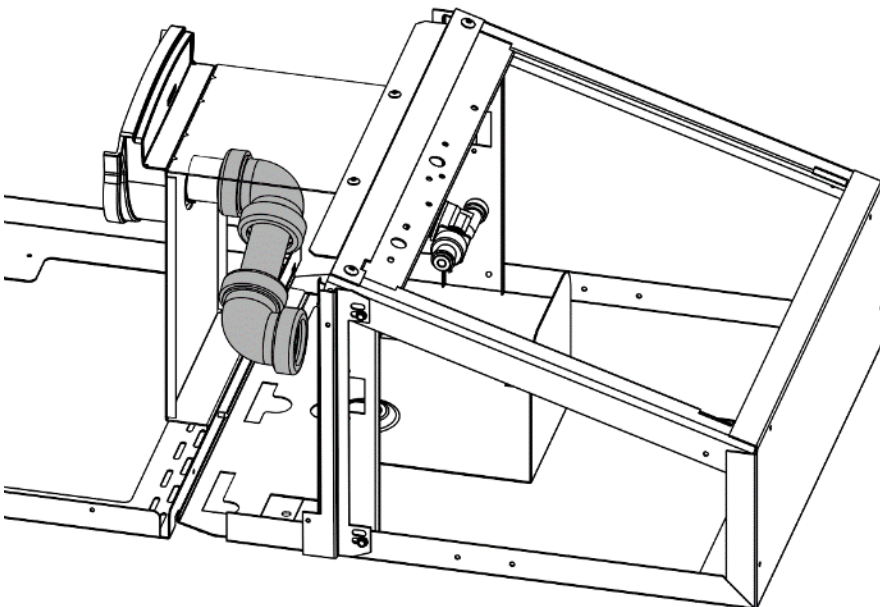

Section 6: Installation

10. Assemble the supplied P-Clip roughly 36" from the grounded plug on the supplied power cord, then secure the P-Clip to the inside surface of the horizontal strut of the fountain frame with a #8 Torx screw.

NOTE: Only one of the two power cords from the kits will be used.

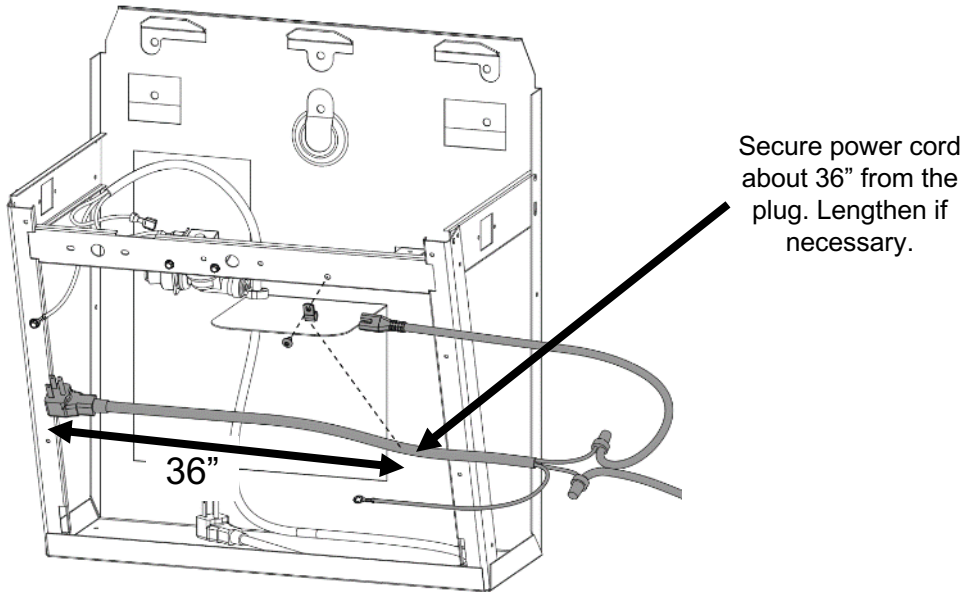

11. Install the ring terminal to the inside vertical strut of the dummy unit with the provided #8 thread cutting hex screw. Screw into one of the empty flared holes of the strut.

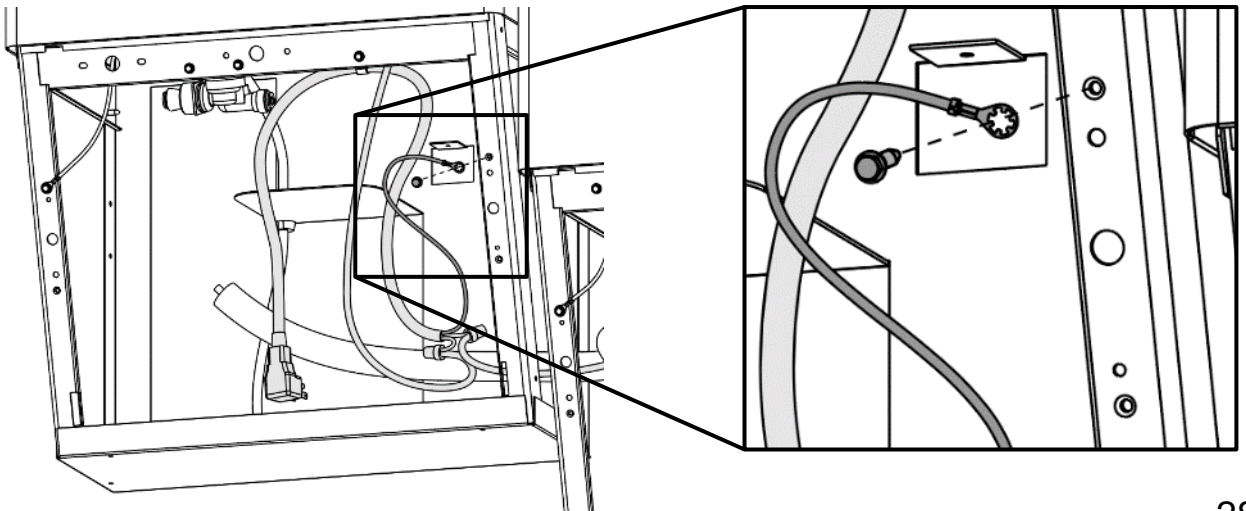

Section 6: Installation

12. Disconnect the IEC connector from the power brick located behind the alcove. Set aside but do not discard the supplied power cord. Do not remove the power brick.

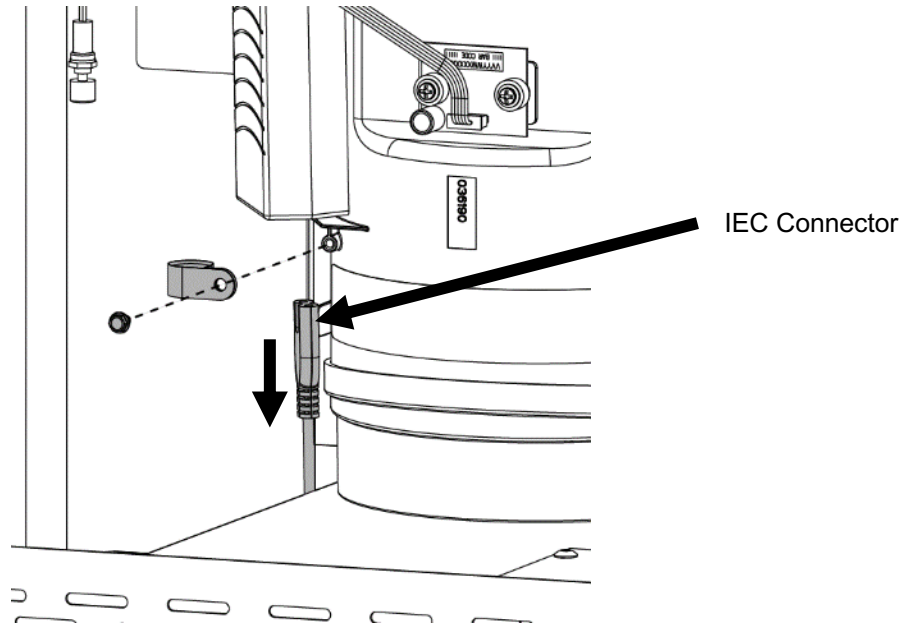

13. Secure the wrapper assembly to the unit by inserting the 6, #8 Torx screws into the frame and side brackets. **Refer to pages 15. Do not perform the steps on page 16 yet.**

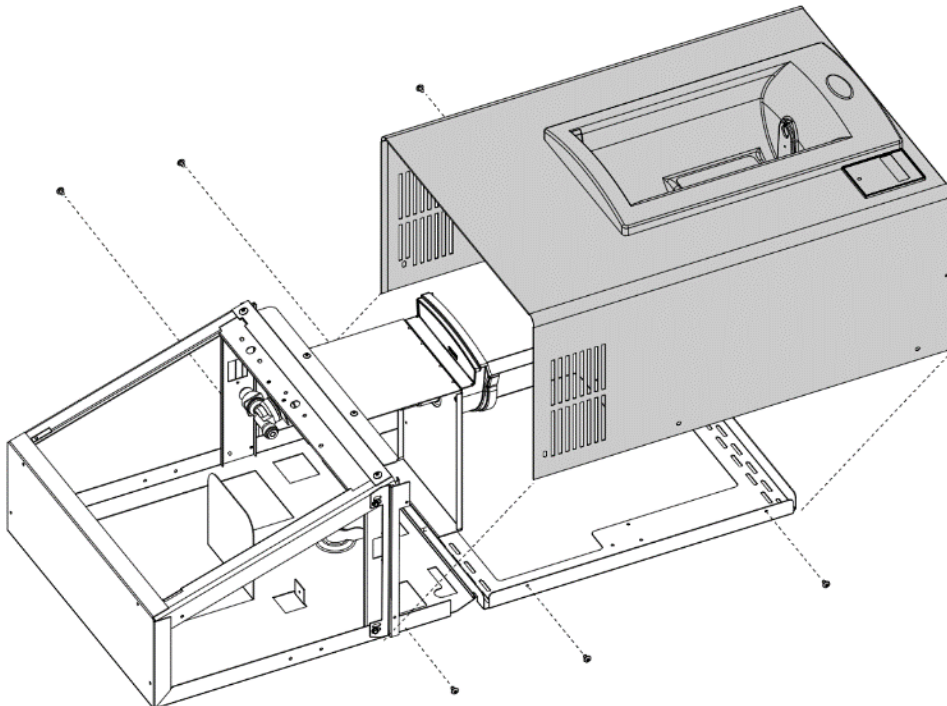

Section 6: Installation

14. Pick up the assembly by taking hold of both the fountain frame and NNEBFEZ cabinet, then hang the fountain on the wall hanging bracket.

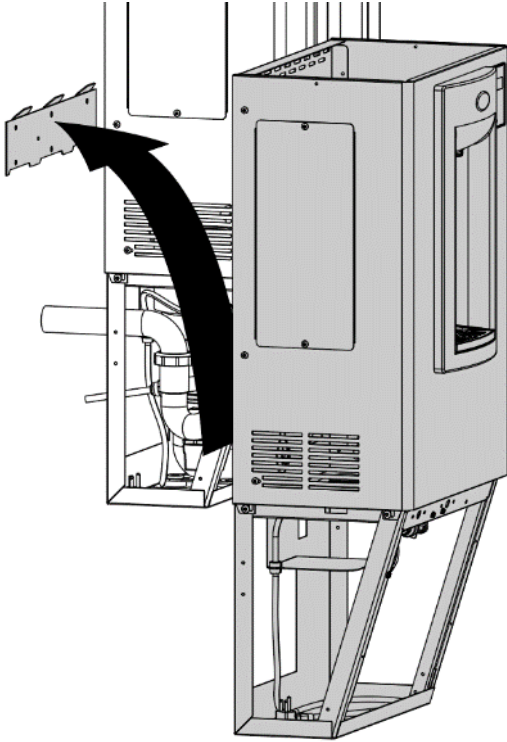

NOTE: Ensure that the NNEBFEZ frame sits on top of the fountain frame. Center the cabinet on the frame as shown on **page 11**. Some extra positioning may be necessary.

15. Ensure that the frame is flat against the wall and install your four chosen anchors (not supplied) into the wall to secure the unit. Ensure that the frame does not shift and is still centered, sitting on the frame of the cooler frame.

Once secured, follow **step 9** on **page 16** if necessary.

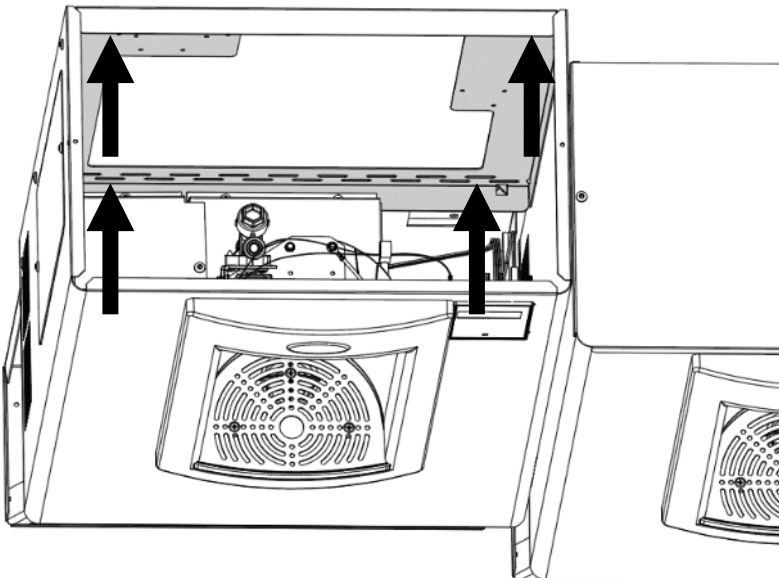

Section 6: Installation

16. After the NNEBFZ has been hung, the fountain frame may not properly sit back on the wall. Loosen the side screws so that the fountain may rest against the wall, then re-tighten the side screws.

NOTE: Only one side screw will be accessible on the side facing the other fountain unit. Loosen the most outward screw to allow the unit to fall into position, then re-tighten.



17. Install the provided long drainpipes to the elbow fittings of each unit. Next, install the Elkay drainpipes to connect the drains and then connect to the P-Trap. Cut provided pipes as needed.

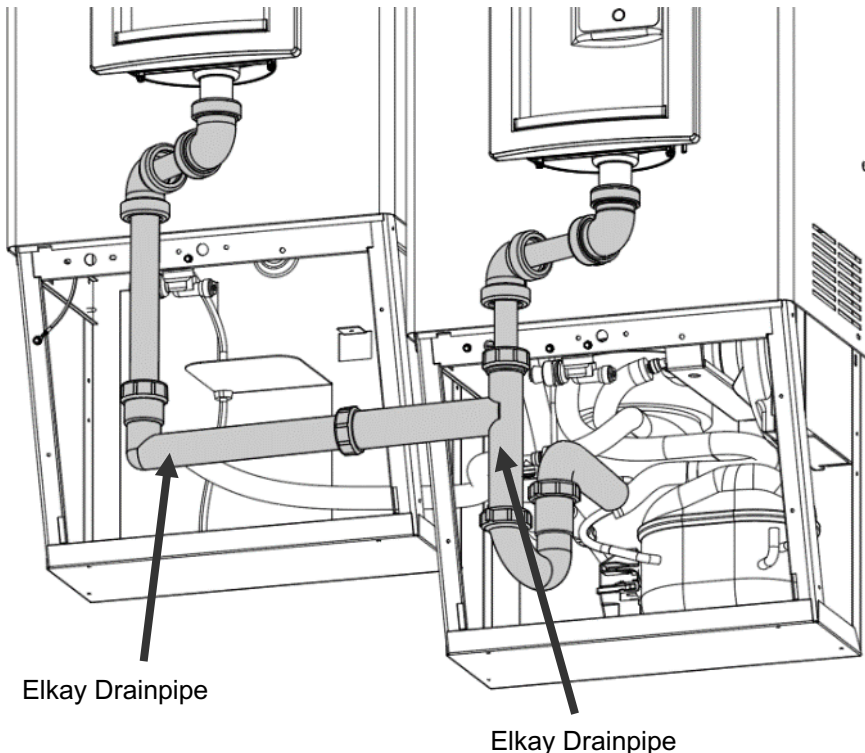

Section 6: Installation

18. Connect the provided $\frac{1}{4}$ " union fittings to the water-out lines of each fountain (see **page 23**). Connect the the provided $\frac{1}{4}$ " water lines and sponge tubing from each kit to the fountain water out lines and install into the solenoid located on top of the alcove. Reference **page 17**.
19. Turn on the water supply and check for leaks.
20. Plug in the power cords for the refrigerated unit and the cord for the NNEBFEZ units. DO NOT plug in the dummy unit power cord. Check for any malfunctions.
21. Reinstall the NNEBFEZ top panel and fountain wrappers with the appropriate screws.
22. The NNEBFEZ comes pre-programmed from the factory. For programming options, please refer to **page 33**.

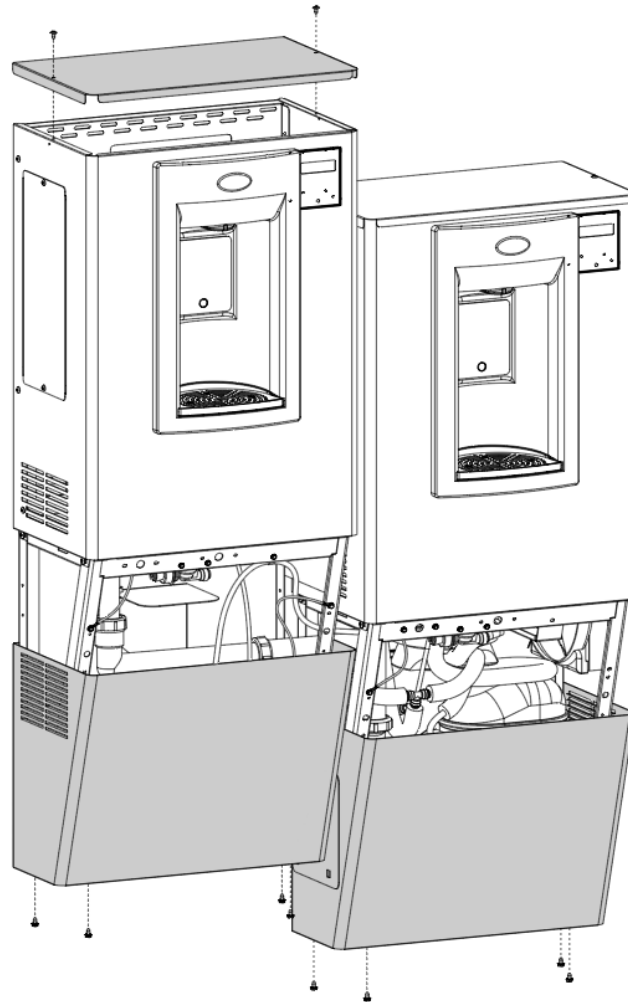

Section 6: Set-Up Guide For OASIS® Hands-Free Bottle Filler Electronics

•Factory default program settings are:

- Units - Gallons
- Unfiltered unit
- Flow Meter = Rate Selected
- Filter Capacity = 1250 gallons [4731 liters] for a VersaFilter
- Bottle Count = 0.5L (1 Bottle)
- Flow Rate = 1.2 GPM
- 20 second maximum dispense time

•For each model top cap will need to be set aside until programming is complete. Remove top cap by unscrewing two (2) T15 torx screws if needed. Remove wire tie bundling pushbutton inside bottle filler and feed it through hole in cooler top. You can then adjust program using pushbutton through access panel of cooler.

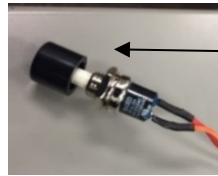

•Pushbutton

•To change the program settings, follow these steps:

| <u>Display</u> | <u>Action</u> |
|---|--|
| 00000000 BOTTLES REUSED (Home Screen) | Depress button for 3 seconds to enter into the following menu settings and make changes. Note: at anytime it will exit menu and save settings when idle for 10 seconds (no button press) and revert back to Home Screen. |
| LTR/GAL GAL | Depress button 3 seconds to change from Gallons to Liters, or momentary press to advance to next menu. |
| UNFILT/FILT? UNFILT UNIT | Depress button 3 seconds to change from Unfiltered to Filtered unit, or momentary press to advance to next menu. |
| FLOW METER? RATE SELECTED | Depress button 3 seconds to change from Rate Selected to (Flow) Meter Enabled, or momentary press to advance to next menu. |
| SELECT RATE 1.2 GPM UNIT | To change flow rate, momentarily depress button to change whole gallon digit. Hold button 3 seconds to advance to TENTHS of gallon digit. Depress momentarily to change the digit. Hold button 3 seconds to advance to the next menu. |
| RESET 00000000 GALLON CNT [LTR COUNT] | Depress button for 3 seconds to reset Gallon or Liter count, or momentary press to advance to next menu. |
| FILT CAPAC OF 1250 GAL [4731 LTR] | Depress button for 3 seconds to change filter capacity to 3000 GAL [11355 liters] for Galaxi green filter, or momentary press to advance to next menu. |
| 3 sec rule? 0.5L | Depress button for 3 seconds to switch from 0.5L bottle to 3 sec rule, or momentary press to advance to next menu. (The 3 Sec rule increases the bottle count based on a 3 second dispense.) |
| Reset 00000000 BOT COUNT? | Depress button for 3 seconds to reset (Home Screen) BOTTLES REUSED count, or momentary press to advance to next menu. |
| Bot Filler Set_time: 20 s | Depress button for 3 seconds to change maximum dispense time to 10, 20 or 30 seconds, or momentary press to advance to next menu. |
| RUN CAL AGAIN? | Depress button 3 seconds to run calibration again, or momentary press to advance to next menu. |

Section 5: Parts Breakdown

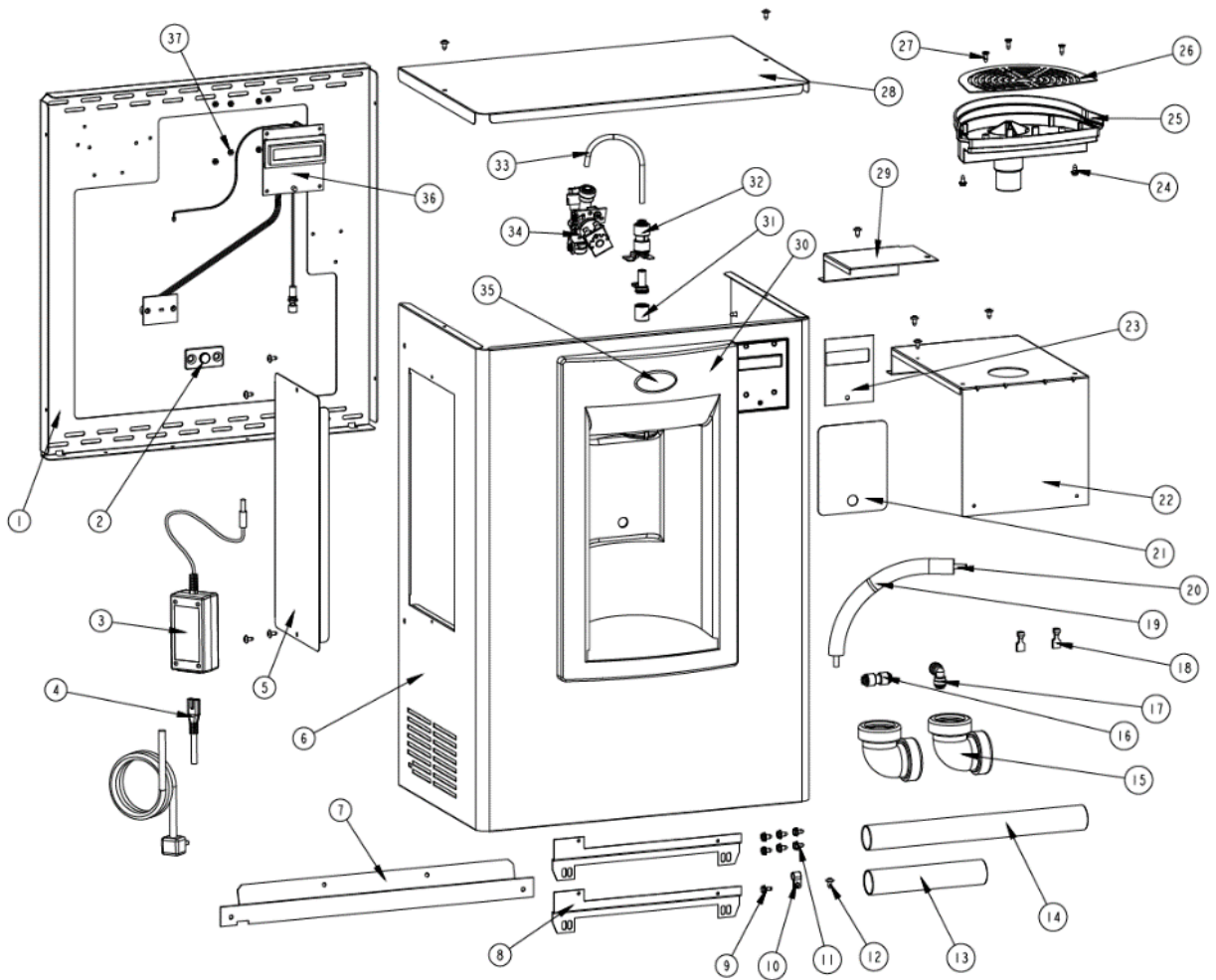

| ITEM | QTY | P/N | Description |
|------|-----|---------------|--------------------------------|
| 1 | 1 | 041245-001 | Frame |
| 2 | 1 | 038027-001 | Lens, IR Bottle Filler |
| 3 | 1 | 038168-004 | Cord Assy, DC Power Supply |
| 4 | 1 | 041207-001 | Power Supply, 100-240VAC/12VDC |
| 5 | 1 | 041241-001 | Panel, NN Filter |
| 6 | 1 | 041238-001 | Wrapper, ENN |
| 7 | 1 | 041243-001 | Bracket, Center ENN |
| 8 | 2 | 041242-001 | Bracket, ENN Side |
| 9 | 1 | 026670-001 | Screw, Hex Head Machine |
| 10 | 1 | 018541 | Clamp, Strain Relief |
| 11 | 6 | 026642-010 | Screw, #10 Hex HD Tapping |
| 12 | 13 | 031875-003 | Screw, Truss HD Tapping |
| 13 | 1 | 036010-002 | Waste, Tube 6.13" |
| 14 | 1 | 036010-013 | Waste, Tube 11.63" |
| 15 | 2 | A020967 | 1 1/2" Elbow, W/Nuts, 1 1/4" |
| 16 | 1 | 028605-101 | FTG, PP Union 1/4"OD |
| 17 | 1 | 028481-101 | FTG, PP Union Elbow WHT 0.25 |
| 18 | 2 | 026923 | Terminal, 0.250 Insulated STR |
| 19 | 1 | 017681-003-SP | Insulation, Sponge Tube 9" |

| ITEM | QTY | P/N | Description |
|------|-----|---------------|-----------------------------|
| 20 | 1 | 030152-102-SP | Tube, PE Cut Length WHI 10" |
| 21 | 1 | 038031-006 | Label, Alcove Sensor |
| 22 | 1 | 041244-001 | Bracket, ENN Drain |
| 23 | 1 | 038031-005 | Label, LCD Bezel |
| 24 | 2 | 026642-003 | Screw, #8 Hex HD Tapping |
| 25 | 1 | 036191-001 | Drain, MSBF, Short |
| 26 | 1 | 036192-001 | Grille, Bottle Filler Drain |
| 27 | 3 | 026675-003 | Screw, Flat HD Tapping |
| 28 | 1 | 041239-001 | Panel, ENN Top |
| 29 | 1 | 041246-001 | Bracket, ENN Filter Support |
| 30 | 1 | 036190-003 | Alcove, EBF |
| 31 | 1 | 038032-001 | Flow Nozzle |
| 32 | 1 | 028668-101 | FTG, PP Reducing Union |
| 33 | 1 | 030152-009-SP | Tube, PE White 7.5" |
| 34 | 1 | 038030-002 | Solenoid Valve 12VDC |
| 35 | 1 | 031434-014 | Nameplate, OASIS |
| 36 | 1 | 038026-002 | Electronics ASSY, IR/LCD |
| 37 | 8 | 026824-026 | Nut, Hex Nylon |

OWNER'S COPY

1 YEAR

BOTTLE FILLER LIMITED WARRANTY

FIRST YEAR

The manufacturer promises the original purchaser (user) to repair, give credit for, or, at the manufacturer's option, to replace any part of this bottle filler which proves to be inoperative due to a defect in material or workmanship under normal use, for a period of one year from the date of original installation or for a period of eighteen (18) months after date of shipment from the factory, whichever occurs first. During the one year warranty, the Manufacturer will either replace, give credit for, or repair the bottle filler through its approved service center or factory repair department, and provide labor and parts necessary to correct such inoperative condition at no charge, if it has been installed and operated in accordance with the written instruction furnished with the bottle filler.

If it becomes necessary to ship the inoperative bottle filler to the approved service center or factory repair department, the Manufacturer will pay the transportation charges both ways via common carrier. Local delivery charges are not covered.

The cost of labor required to disconnect and reconnect plumbing and electrical connections will be the responsibility of the user (owner).

WARNING

Alteration or modification of this machine may cause serious flooding and/or hazardous electrical shock or fire.

Except as set forth herein, the Manufacturer makes no other warranty, guarantee or agreement expressed, implied or statutory, including any implied warranty of merchantability or fitness for a particular purpose.

The foregoing is in lieu of all other agreements expressed, implied or statutory and all other obligations or liabilities of the Manufacturer. The Manufacturer does not assume or authorize any person to assume any obligations of liability in connection with this product. In no event will the Manufacturer be liable for special or consequential damages or for any delay in the performance of this agreement due to causes beyond their control.

GENERAL PROVISIONS AND EXCLUSIONS:

This warranty applies only within the Continental Limits of the United States of America and Canada.

This warranty does not apply and no agreement, either expressed or implied, shall be applicable if the affixed serial number is removed, defaced or obliterated.

This warranty does not apply to any water components that become inoperative due to liming conditions.

This warranty does not apply to any bottle filler or components that become inoperable because of a failure to satisfy standards or regulations adopted by any government or agency thereof subsequent to the date of shipment from the factory.

This warranty does not cover performance, failure or damages of any parts resulting from external causes such as alterations, abuse, misuse, misapplication, corrosion or acts of God.

This warranty applies only to the bottle filler portion. It does not apply to the water cooler. Refer to the water cooler warranty for coverage.



OASIS International
222 East Campus View BLVD • Columbus, OH 43235 U.S.A.

Phone: 1-800-950-3226
Email: www.oasiscoolers.com

THIS PAGE IS INTENTIONALLY LEFT BLANK

Model NNEBFEZ Chilled Bottle Filler Retrofit Kit for ELKAY LZ8 Water Coolers

Installation Instructions

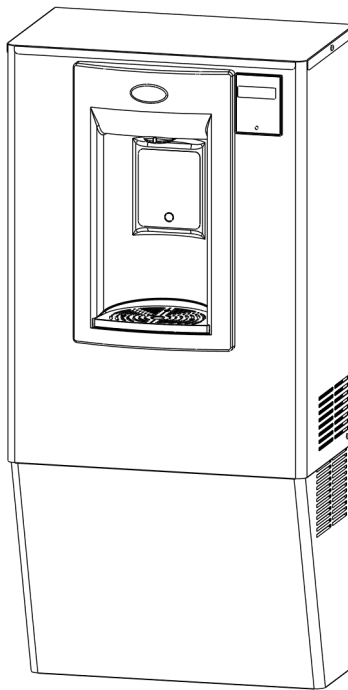

P/N 030099-640 Rev E Date: 01/2021
© 2021 LVD Acquisition, LLC

Oasis, Aqua Pointe, Versacooler and VersaFiller are registered trademarks of LVD Acquisition, LLC dba Oasis International

The ELKAY trademark is registered and owned by Elkay Manufacturing Company. OASIS International is not affiliated with Elkay Manufacturing Company in any way. No OASIS International Products are associated or affiliated with, sponsored or endorsed by the Elkay Manufacturing Company.



OASIS INTERNATIONAL
222 East Campus View Blvd.
Columbus, OH 43235
614-861-1350
www.oasiscoolers.com