



### Suggested Specification

Model PFCPD10EBF shall deliver 10.0 gph of 50°F water at 90°F ambient and 80°F inlet water per ASHRAE 18 testing. Shall be freestanding in design with mechanical foot pedal and laminar flow. Bottle Filler alcove and cabinet finish shall be stainless steel. Key bottle filler components contain Freshield, which utilizes a silver-based antimicrobial compound to protect the surfaces from discoloration, odors and degradation caused by the growth of micro-organisms and mildew. Evaporator shall be high efficiency tank type and shall be encapsulated in insulation. An adjustable thermostat having an off position shall control refrigeration system. Shall use R-134a refrigerant. Shall comply with ANSI 117.1 and ADA. Shall be listed by Underwriters Laboratories to US and Canadian standards. Shall comply with NSF/ANSI 61 and NSF/ANSI 372.

<b>Features:</b>	• Built-in 100 micron strainer stops particles before they enter the waterway
	• Waterways are Lead-Free in materials & construction
	• High efficiency cooling system
	• Bottle filler with programmable auto shut off
	• High flow output of 1.1 gallons per minute for faster fill up
	• Built in drain - no drip tray to empty
	• Hands-free foot pedal operation for flow of water
	• Easy to wash, removable MERV 3 air filter
	• Built-in filter monitor and bottle counter
	• Logos permanently formed into the alcove and stainless steel wrapper
• LED lighted alcove	
• Removable front panel for ease of filter change-out	

<b>Filtration:</b>	OASIS Outdoor certified to NSF/ANSI 42, 53, 372 and 401 for lead, cysts, Particulate Class I, chlorine, taste, odor and microplastics reduction to 4,750 gallons.
<b>Power:</b>	115 Volts, 60 Hz
<b>Activation By:</b>	Mechanically Activated foot pedal
<b>Mounting Type:</b>	Free Standing
<b>Chilling Option:</b>	10.0 gph*
<b>Full Load Amps</b>	5.5 amps
<b>Rated Watts</b>	550
<b>Approx. Net Weight</b>	75 lbs
<b>Approx. Gross Weight</b>	81 lbs
<b>Installation Location:</b>	Indoor/Outdoor

When used or stored in non-temperature controlled environments, the unit must be adequately winterized and/or protected from extreme heat to prevent damage.

MODEL: \_\_\_\_\_ QTY: \_\_\_\_\_

PROJECT: \_\_\_\_\_

CONTACT: \_\_\_\_\_

NOTES: \_\_\_\_\_

APPROVAL: \_\_\_\_\_ DATE: \_\_\_\_\_

## OUTDOOR FREESTANDING BOTTLE FILLER, MECHANICAL, REFRIGERATED, OUTDOOR FILTER MODEL PFCPD10EBF



**Ships in one box.**

### Installation

- Shipped with complete instructions
- Mounting brackets provided

### Finishes

- Standard cabinet finish: Stainless steel

### Limited 5-Year Warranty

(Continental limits of the United States and Canada) Five years on the sealed refrigeration system. Bottle fillers, fountains, and electrical components are warranted for 12 months. Detailed warranty certificate enclosed with each water cooler; sample available upon request.

### Export Warranty

One year on components parts. Detailed warranty certificate enclosed with each drinking fountain; sample copy available upon request.

### Certifications/Compliance

- Certified to UL 399 and CAN/CSA C22.2 No.120 (electric water coolers only)
- Product Certified to NSF/ANSI Standard 61-G & 372 and conforms with the lead content requirements for "Lead Free" plumbing as defined by California, Vermont, Maryland, and Louisiana state laws and the U.S. Safe Drinking Water Act
- These water coolers comply with the requirements of ADA (Americans with Disabilities Act) when properly installed

\*Industry standard rating condition at 90°F ambient, 80°F inlet water and 50°F drinking water temperature



**WARNING:**  
Cancer and Reproductive Harm  
[www.P65Warnings.ca.gov](http://www.P65Warnings.ca.gov)



Specifications subject to change without notice



OUTDOOR FREESTANDING BOTTLE FILLER,  
MECHANICAL, REFRIGERATED, OUTDOOR FILTER  
**MODEL PFCPD10EBF**

## Accessories



### OASIS Outdoor Replacement Cartridge

OASIS Item #041667-001

- Certified to NSF/ANSI 42, 53 and 401 for lead, cysts, Particulate Class I, chlorine, taste, odor and microplastics reduction to 4,750 gallons.



[View all filters and accessories](#)



OUTDOOR FREESTANDING BOTTLE FILLER,  
MECHANICAL, REFRIGERATED, OUTDOOR FILTER  
**MODEL PFCPD10EBF**

ALL DIMENSIONS ARE IN INCHES.

DIMENSIONS IN BRACKETS [ ]  
ARE IN MILLIMETERS.

ALLOW 4"[102] FOR VENTILATION AT THE  
REAR OF THE WATER COOLER AND THE  
SIDES IF SET IN AN ALCOVE OR NEAR A  
CORNER.

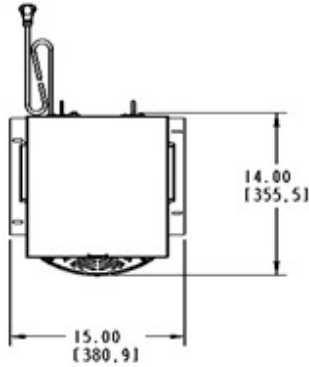

PLAN VIEW

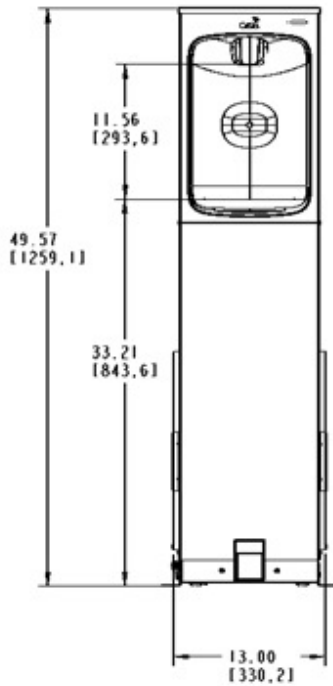

FRONT VIEW

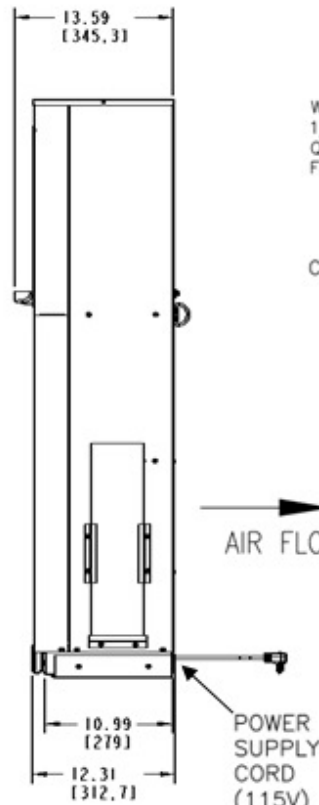

RIGHT SIDE  
VIEW

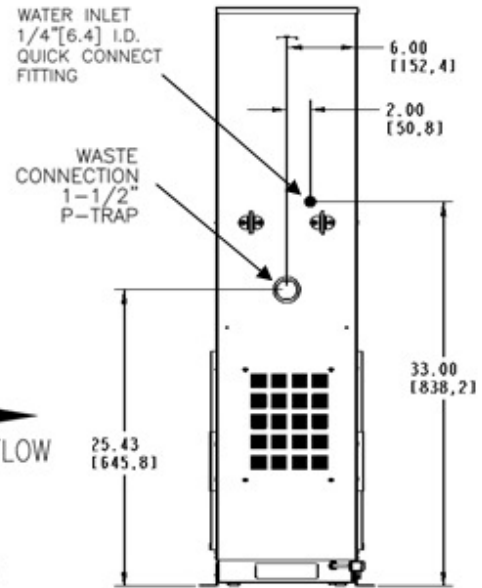

REAR VIEW