



BARRIER-FREE VERSACOOLER® II

**Energy and Water Conservation Technology
PGF8AC-CSTN, PGFAC-CSTN**

Suggested Specification

Model PGF8AC-CSTN shall deliver 8.0 gph of 50°F degree water at 90° F ambient and 80°F inlet water. Model PGFAC-CSTN is a non-refrigerated drinking fountain and delivers ambient water. Shall include four antimicrobial copper push pads. Shall have VersaFilter for taste, odor, lead and chlorine reduction. Basin shall be designed to eliminate splashing and standing water. Water saver bubbler reduce waste water by 50% and shall have flexible guard and operate between 20 and 100 PSI. Cabinet finish shall be stainless steel with antimicrobial copper top and nose assembly. Shall use R-134a refrigerant. Shall comply with ANSI 117.1 and ADA. Shall be listed by Underwriters Laboratories to US and Canadian standards. Shall comply with ANSI/NSF 61 and NSF/ANSI 372.

Models

- PGF8AC-CSTN delivers 8.0 gallons of chilled drinking water per hour.
- PGFAC-CSTN is a non-refrigerated fountain.

Standard Features

- Built-in 100 micron strainer stops particles before they enter the waterway.
- VersaFilter for taste, odor, lead and chlorine reduction
- Waterways are Lead-Free in materials & construction.
- Flexible and one-piece water saver bubbler guard
- Stainless steel top and heavy duty galvanized steel frame
- High efficiency cooling system
- Refrigerant R-134a
- Four antimicrobial copper push pads
- Antimicrobial copper top and nose assembly
- External stream height adjustment

Finishes

- Standard cabinet finish: Stainless steel

Installation

- Prior to roughing consult with local, state and federal codes for proper mounting height
- Shipped with complete instructions and wall mounting bracket
- Removable side and front panels provide easy access for installation.

Options (at additional cost)

- Glass fillers (factory installed)
- Push handle (029603-004)
- One piece chrome plated brass bubbler (036700-001)
- Filter replacement cartridge (033879-001)

Limited 5-Year Warranty

(Continental limits of the United States and Canada)
Five years on the sealed refrigeration system and most component parts. Detailed warranty certificate enclosed with each water cooler; sample available upon request.

Export Warranty

One year on components parts. Detailed warranty certificate enclosed with each drinking fountain; sample copy available upon request.

Certifications/Compliance

- Antimicrobial Copper - EPA Registration No. 89187-3
- Oasis International Electric Water Coolers are listed by Underwriters Laboratories Inc. and comply with both U.S. and Canadian Requirements.
- Product Certified to NSF/ANSI Standard 61-G & 372 and conforms with the lead content requirements for "Lead Free" plumbing as defined by California, Vermont, Maryland, and Louisiana state laws and the U.S. Safe Drinking Water Act.
- This unit complies with ARI standard 1010 Testing, Operating and Rating requirements (electric water coolers only).
- These water coolers comply with the requirements of ADA (Americans with Disabilities Act) when properly installed.



Model	50° F Drinking Water 90° F Ambient Air Temp*			Hot°N Cold Model	115 Volts, 60 HZ			Glass Filler Acc. Option	Cabinet Color Finish	Net Wt. Approx
	Rated Capacity GHP	Base Rate GHP	Pre-Cooler		Compr. HP	Full Load Amps	Rated Watts			
PGF8AC-CSTN	8.0	8.0	No	No	1/4	4.4	450	Yes	Yes	59 Lbs
PGFAC-CSTN	Fountain Only							Yes	Yes	25 Lbs

* Industry standard rating condition 80° F inlet water temperature

Specifications subject to change without notice

OASIS® VERSACOOLER® II

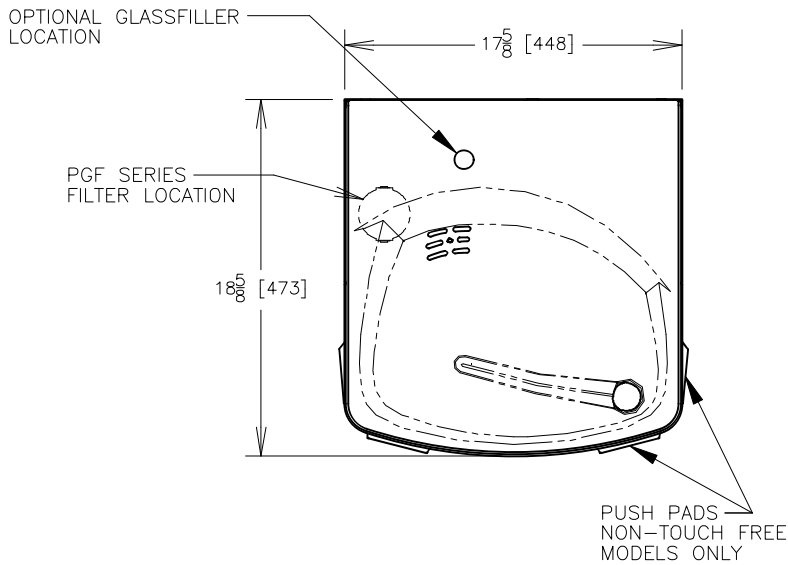

NOTES:

1. TRAP, STOP VALVE AND ELECTRICAL OUTLET NOT FURNISHED.
2. ALLOW 4 INCHES [102 MM] MIN. PER SIDE FOR VENTILATION.
- *3. RECOMMENDED ADULT BARRIER FREE HEIGHT INSTALLATION SHOWN. REDUCE HEIGHT BY 3 INCHES FOR INSTALLATIONS USED PRIMARILY BY CHILDREN AGES 12 AND YOUNGER. UNIT SHALL ALSO HAVE A MINIMUM CLEAR FLOOR SPACE 30[760] BY 48[1220]. ADJUST VERTICAL DIMENSIONS AS REQ'D TO COMPLY WITH FEDERAL, STATE, AND LOCAL CODES.
4. ALL DIMENSIONS ARE IN INCHES. DIMENSIONS IN BRACKETS [] ARE IN MILLIMETERS.

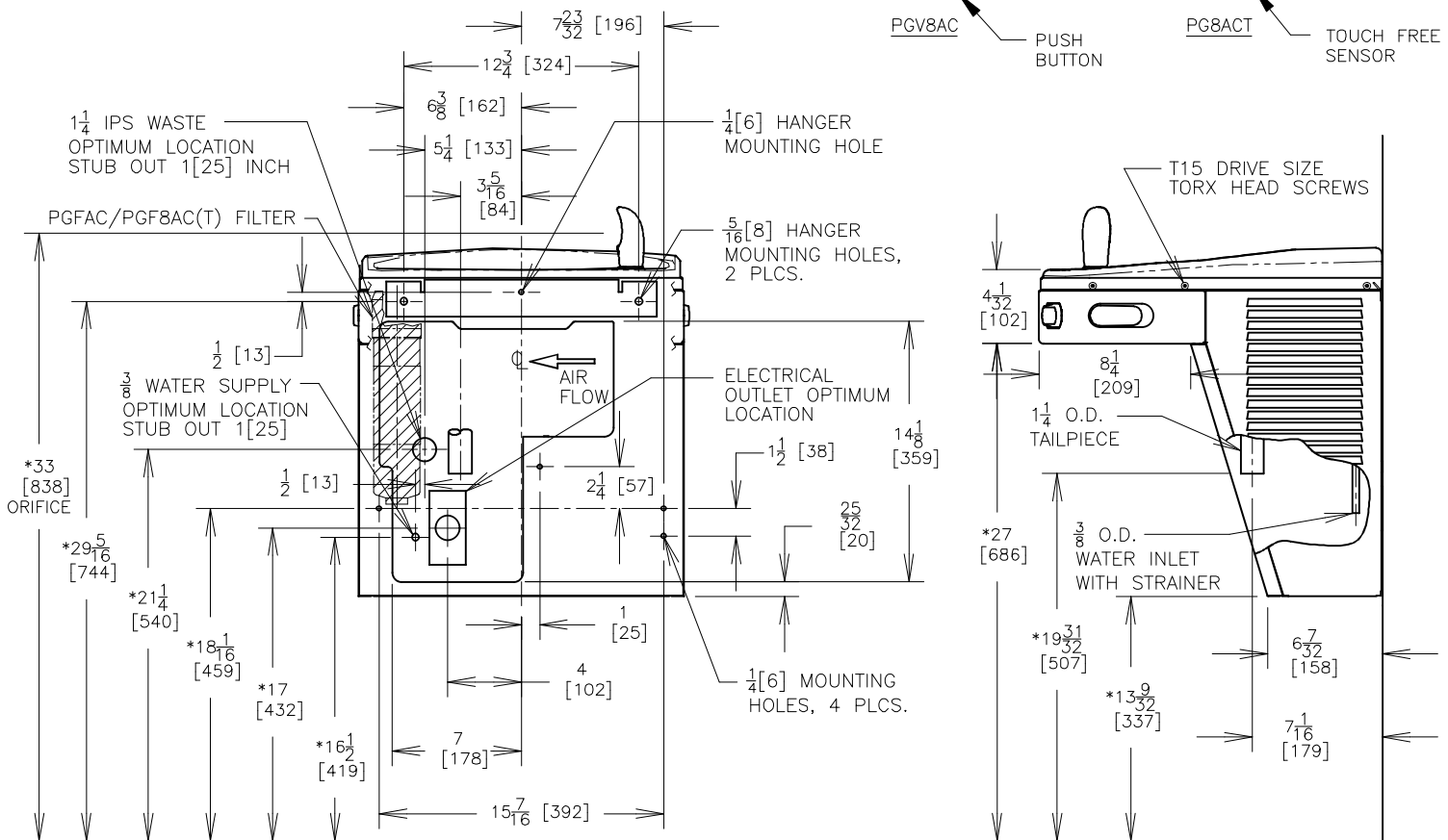
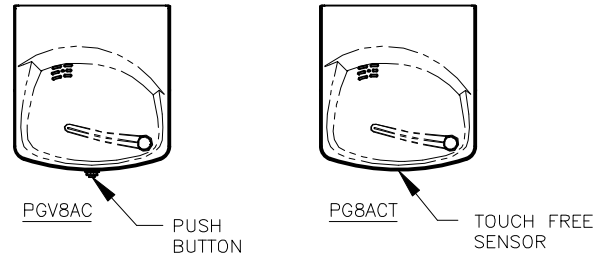

THIRD ANGLE PROJECTION

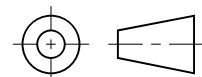

ROUGHING-IN AND DIMENSIONAL DRAWING

